



# FACILITY **ACCESSIBILITY** DESIGN STANDARDS



**May 2019**

**City of Kingston**

## Acknowledgements

### Re: City of Kingston 2019 Facility Accessibility Design Standards

On behalf of the Corporation of the City of Kingston we are pleased to be able to present to you our 2019 Facility Accessibility Design Standards. This updated document outlines City-wide standards that build a universally-designed and accessible community for residents, visitors and employees.

#### What's new:

- changes to the Ontario Building Code 2012 (including 2015 accessibility updates);
- the Accessibility for Ontarians with Disabilities Act's (AODA) Accessibility Standards for the Design of Public Spaces (O. Reg. 413/12); and
- additional sections: therapeutic pools, spray pads, streetscapes, wayfinding and information systems, maintenance, and colour contrasting.

These standards are applied to all new and/or renovated City owned, leased or operated facilities. In addition to our municipal facilities, we encourage their use throughout the community.

#### We would like to thank and recognize contributions of:

- The City of London for its generous permission to use the City of London 2009 Facility Accessibility Design Standards (FADS 2009) as the basis for this standard;
- The City of Kingston Municipal Accessibility Advisory Committee for their input into this update, and support and promotion of these standards in the community and;
- The City of Kingston staff from various departments who have taken the time to provide their input concerning this update.

These standards are a key component of the City's vision for accessibility to make Kingston a great place to live, work, and play for everyone. They reflect our corporate values of Teamwork, Respect, Integrity, and Pride, and ensure Kingston is a place where everyone belongs.

**Table of Contents**

Minimum Design Elements ..... 6

1.0 INTRODUCTION ..... 9

2.0 GLOSSARY AND DEFINITIONS ..... 11

3.0 SCOPE AND APPLICATION ..... 19

4.0 DESIGN STANDARDS ..... 23

    4.1 ACCESS AND CIRCULATION ..... 24

        4.1.1 SPACE AND REACH REQUIREMENTS ..... 24

        4.1.2 GROUND AND FLOOR SURFACES ..... 31

        4.1.3 PROTRUDING & OVERHEAD OBJECTS ..... 33

        4.1.4 ACCESSIBLE ROUTES, PATHS & CORRIDORS ..... 36

        4.1.5 ENTRANCES ..... 40

        4.1.6 DOORS ..... 42

        4.1.7 GATES, TURNSTILES AND OPENINGS ..... 52

        4.1.8 WINDOWS, GLAZED SCREENS & SIDELIGHTS ..... 54

        4.1.9 RAMPS ..... 56

        4.1.10 CURB RAMPS ..... 62

        4.1.11 STAIRS ..... 68

        4.1.12 HANDRAILS ..... 72

        4.1.13 ESCALATORS ..... 75

        4.1.14 ELEVATORS ..... 76

        4.1.15 PLATFORM LIFTS ..... 83

    4.2 WASHROOM FACILITIES ..... 85

        4.2.1 TOILET FACILITIES ..... 85

        4.2.2 TOILET STALLS ..... 89

        4.2.3 TOILETS ..... 94

        4.2.4 LAVATORIES ..... 97

        4.2.5 URINALS ..... 99

        4.2.6 WASHROOM ACCESSORIES ..... 101

        4.2.7 UNIVERSAL WASHROOMS ..... 102

        4.2.8 BATHTUBS ..... 108

        4.2.9 SHOWER STALLS ..... 111

        4.2.10 GRAB BARS ..... 114

|   |     |
|---|-----|
| 4.3 OTHER AMMENITIES.....   | 116 |
| 4.3.1 DRINKING FOUNTAINS.....   | 116 |
| 4.3.2 VIEWING POSITIONS.....  | 119 |
| 4.3.3 ELEVATED PLATFORMS.....   | 123 |
| 4.3.4 DRESSING ROOMS.....   | 125 |
| 4.3.5 OFFICES, WORK AREAS & MEETING ROOMS.....                          | 127 |
| 4.3.6 WAITING AND QUEUING AREAS.....                                    | 129 |
| 4.3.7 TABLES, COUNTERS AND WORK SURFACES.....                           | 131 |
| 4.3.8 INFORMATION, RECEPTION AND SERVICE COUNTERS.....                  | 134 |
| 4.3.9 STORAGE, SHELVING AND DISPLAY UNITS.....                          | 136 |
| 4.3.10 LOCKERS AND BAGGAGE STORAGE.....                                 | 137 |
| 4.3.11 BALCONIES, PORCHES, TERRACES AND PATIOS.....                     | 141 |
| 4.3.12 PARKING.....   | 142 |
| 4.3.13 PASSENGER-LOADING ZONES.....                                     | 145 |
| 4.3.14 LANDSCAPING MATERIALS AND PLANTINGS.....                         | 148 |
| 4.3.15 BENCHES.....   | 149 |
| 4.3.16 PUBLIC USE EATING AREAS.....                                     | 152 |
| 4.3.17 STREETSCAPES.....  | 155 |
| 4.3.18 KITCHENS AND KITCHENETTES.....                                   | 158 |
| 4.3.19 SERVICE ANIMAL RELIEF AREAS.....                                 | 165 |
| 4.4 SYSTEMS AND CONTROLS.....   | 165 |
| 4.4.1 EMERGENCY EXITS, FIRE EVACUATION AND AREAS OF RESCUE ASSISTANCE.. | 165 |
| 4.4.2 CONTROLS AND OPERATING MECHANISMS.....                            | 168 |
| 4.4.3 VENDING AND TICKETING MACHINES.....                               | 171 |
| 4.4.4 VISUAL ALARMS.....  | 173 |
| 4.4.5 PUBLIC TELEPHONES.....  | 174 |
| 4.4.6 ASSISTIVE LISTENING SYSTEMS.....                                  | 178 |
| 4.4.7 SIGNAGE.....  | 179 |
| 4.4.8 DETECTABLE WARNING SURFACES.....                                  | 184 |
| 4.4.9 PUBLIC ADDRESS SYSTEMS.....                                       | 187 |
| 4.4.10 INFORMATION SYSTEMS.....   | 188 |
| 4.4.11 CARD ACCESS, SAFETY AND SECURITY SYSTEMS.....                    | 191 |
| 4.4.12 GLARE AND LIGHT SOURCES.....                                     | 192 |

|   |     |
|---|-----|
| 4.4.13 LIGHTING .....   | 194 |
| 4.4.14 MATERIALS AND FINISHES.....                                | 196 |
| 4.4.15 TEXTURE AND COLOUR .....                                   | 198 |
| 4.4.16 ACOUSTICS.....   | 201 |
| 4.4.17 PEDESTRIAN SIGNALS .....                                   | 202 |
| 4.5 FACILITY-SPECIFIC REQUIREMENTS .....                          | 203 |
| 4.5.1 ARENAS, HALLS AND OTHER INDOOR RECREATIONAL FACILITIES..... | 203 |
| 4.5.2 OUTDOOR RECREATIONAL FACILITIES.....                        | 205 |
| 4.5.3 SWIMMING POOLS .....  | 212 |
| 4.5.4 CAFETERIAS .....  | 217 |
| 4.5.5 CHURCHES, CHAPELS AND OTHER PLACES OF WORSHIP.....          | 219 |
| 4.5.6 LIBRARIES .....   | 220 |
| 4.5.7 BUSINESS, MERCANTILE AND CIVIC.....                         | 223 |
| 4.5.8 POLICE STATIONS.....  | 225 |
| 4.5.9 MUNICIPAL COURTS .....                                      | 226 |
| 4.5.10 TRANSPORTATION FACILITIES.....                             | 228 |
| 4.5.11 FIRE HALLS .....   | 229 |
| 4.5.12 AIRPORTS .....   | 230 |
| 4.5.13 RESIDENTIAL FACILITIES .....                               | 231 |
| 4.6 MAINTENANCE AND OPERATIONS .....                              | 232 |
| APPENDIX A - UNIVERSAL DESIGN PRINCIPLES AND GUIDELINES .....     | 234 |
| UNIVERSAL DESIGN:.....  | 234 |
| PRINCIPLE ONE: Equitable Use.....                                 | 234 |
| PRINCIPLE TWO: Flexibility in Use.....                            | 234 |
| PRINCIPLE THREE: Simple and Intuitive Use .....                   | 235 |
| PRINCIPLE FOUR: Perceptible Information .....                     | 235 |
| PRINCIPLE FIVE: Tolerance for Error.....                          | 235 |
| PRINCIPLE SIX: Low Physical Effort.....                           | 236 |
| PRINCIPLE SEVEN: Size and Space for Approach and Use .....        | 236 |
| APPENDIX B - WAYFINDING .....                                     | 237 |
| RATIONALE .....   | 237 |
| DESIGN CONSIDERATIONS.....  | 237 |
| APPENDIX C - COLOUR/BRIGHTNESS CONTRAST .....                     | 239 |

Appendix D: FADS Checklist..... 241  
 Appendix E: Technical Infeasibility Justification Form ..... 247  
 Appendix F: Equivalent Facilitation Proposal Form ..... 248

## **Minimum Design Elements**

The following identifies the minimum design elements that must be considered for EXTERIOR and INTERIOR projects:

### **General Characteristics**

For all aspects of projects, the following general characteristic elements (where provided) must be reviewed for compliance with the standard.

#### **4.1 Access and Circulation**

- 4.1.1 Space and Reach Requirements
- 4.1.2 Ground and Floor Surfaces
- 4.1.3 Protruding & Overhead Objects
- 4.1.4 Accessible Routes, Paths and Corridors
  - 4.1.5 Entrances
  - 4.1.6 Doors
  - 4.1.9 Ramps
  - 4.1.11 Stairs
  - 4.1.12 Handrails

#### **4.3 Other Amenities**

- 4.3.3 Elevated Platforms
- 4.3.11 Balconies, Porches, Terraces And Patios
  - 4.3.15 Benches
  - 4.3.16 Public Use Eating Areas

#### **4.4 Systems and Controls**

- 4.4.7 Signage
- 4.4.8 Detectable Warning Surfaces
  - 4.4.13 Lighting
  - 4.4.14 Materials and Finishes
  - 4.4.15 Texture and Colour

#### **4.5 Facility-Specific Requirements**

- 4.5.3 Swimming Pools, Therapeutic Pools/Public Spas and Spray Pads

## Site Characteristics

When designing the exterior and site, the following site characteristic elements (where provided) must be reviewed for compliance with the standard (in addition to the general characteristics listed above).

### 4.1 Access and Circulation

4.1.10 Curb Ramps

### 4.3 Other Amenities

4.3.12 Parking

4.3.13 Passenger Loading Zones

4.3.14 Landscaping Materials and Plantings

4.3.17 Streetscapes

4.3.19 Service Animal Relief Areas

### 4.4 Systems and Controls

4.4.17 Pedestrian Signals

### 4.5 Facility-Specific Requirements

4.5.2 Outdoor Recreational Facilities

4.5.10 Transportation Facilities

## Building Characteristics

When designing the interior the following building characteristic elements (where provided) must be reviewed for compliance with the standard (in addition to the general characteristics listed on the above).

### 4.1 Access and Circulation

4.1.5 Entrances

4.1.6 Doors

4.1.7 Gates, Turnstiles and Openings

4.1.8 Windows, Glazed Screens and Sidelights

4.1.13 Escalators

4.1.14 Elevators

4.1.15 Platform Lifts

### 4.2 Washroom Facilities

4.2.1 Toilet Facilities

4.2.2 Toilet Stalls

4.2.3 Toilets

4.2.4 Lavatories

4.2.5 Urinals

4.2.6 Washroom Accessories

4.2.7 Universal Washrooms

4.2.8 Bathtubs

- 4.2.9 Showers
- 4.2.10 Grab Bars

**4.3 Other Amenities**

- 4.3.1 Drinking Fountains
- 4.3.2 Viewing Positions
- 4.3.4 Dressing Rooms
- 4.3.5 Offices, Work Areas and Meeting Rooms
- 4.3.6 Waiting and Queuing Areas
- 4.3.7 Tables, Counters and Work Surfaces
- 4.3.8 Information, Reception and Service Counters
- 4.3.9 Storage, Shelving and Display Units
- 4.3.10 Lockers and Baggage Storage
- 4.3.18 Kitchens and Kitchenettes

**4.4 Systems and Controls**

- 4.4.1 Emergency Exits, Fire Evacuation and Areas of Rescue Assistance
- 4.4.2 Controls and Operating Mechanisms
- 4.4.3 Vending and Ticketing Machines
- 4.4.4 Visual Alarms
- 4.4.5 Public Telephones
- 4.4.6 Assistive Listening Systems
- 4.4.9 Public Address Systems
- 4.4.10 Information Systems
- 4.4.11 Card Access, Safety and Security Systems
- 4.4.12 Glare and Light Sources
- 4.4.16 Acoustics

**4.5 Facility-Specific Requirements**

- 4.5.1 Arenas, Halls and Other Indoor Recreational Facilities
- 4.5.2 Outdoor Recreational Facilities
- 4.5.3 Swimming Pools
- 4.5.4 Cafeterias
- 4.5.5 Churches, Chapels and Other Places of Worship
- 4.5.6 Libraries
- 4.5.7 Business, Mercantile and Civic
- 4.5.8 Police Stations
- 4.5.9 Municipal Courts
- 4.5.10 Transportation Facilities
- 4.5.11 Fire Halls
- 4.5.12 Airports
- 4.5.13 Residential Facilities



## 1.0 INTRODUCTION

This standard addresses accessibility requirements for the design and construction of new *facilities*, as well as the retrofit, *alteration* or *addition* to existing *facilities*, owned, leased or operated by the City of Kingston. This standard particularly addresses the needs of persons with *disabilities*, including, but not limited to, persons with a mobility impairment, hearing impairment, visual impairment, cognitive impairment, persons who are deaf-blind and persons with limited stamina and/or dexterity.

This standard is intended to encompass the intent of the Ontario Human Rights Code, in terms of respecting the dignity of persons with *disabilities*. “The phrase ‘respects their dignity’ means to act in a manner which recognizes the privacy, confidentiality, comfort, autonomy and self-esteem of persons with *disabilities*, which maximizes their integration and which promotes full participation in society” (Ontario Human Rights Commission).

This standard incorporates the belief in universal design that recognizes the broad diversity of people who use *facilities*. Universal design is defined as: “The design of products and environments to be usable by all people, to the greatest extent possible, without the need for adaptation or specialized design.”

The universal design philosophy is structured around the seven design principles listed below (refer to Appendix A for further information on the universal design principles and their guidelines).

This standard reflects minimum dimensional criteria required for adult persons. Prior to the design stage of a project, special consideration should be given to the function of the *facility* and the patrons who will use it. A review and upgrade of this standard may be required in some instances, particularly if a *facility* is designed primarily for the use of a particular type of user, such as children or older persons.

Where conflicts exist between scoping and/or dimensional requirements of this standard and legislation enacted by the federal or provincial governments, the most accommodating requirements shall apply (i.e. the requirement(s) that will result in the most accommodating environment but never less than the minimum requirements of the current Ontario Building Code).

The Accessibility staff of the City of Kingston shall review and/or update this standard every 3-5 years, to reflect technological advancement and new construction practices, as well as changes to the barrier-free design requirements of various codes and standards such as the Ontario Building Code and the CSA Standard B651 - Accessible Design for the Built Environment.

This standard recognizes the concept of alternate accommodations as a means to encourage new and innovative design ideas and solutions. Departures from particular technical and scoping requirements of this standard by the use of other designs and technologies are encouraged when the alternatives will provide substantially equivalent or greater access to the usability of the *element* and/or *facility*. Design departures from information provided and referenced in this standard should be carefully assessed to determine if it maximizes integration and promotes full participation. The City of Kingston has developed a design review process which includes a committee to review and evaluate situations that are proposed to be technically infeasible. The process is called the FADS Review and

Alternative Design Review Process. Refer to Appendix D for further information. A Design Checklist has been developed to assist staff, designers and contracted consultants with the application of the FADS to ensure that each element has been applied to each project, and to document elements of a project that may be technically infeasible to implement.

Dimensions used in this standard are in metric units. Approximate imperial equivalent dimensions are in parentheses.

For the purposes of this standard, words and terms in *italics* have their meanings defined in Section 2.0.

The City of Kingston encourages all users of this standard to provide feedback, as well as to make proposals for changes, additions and/or deletions. A proposed Change Order Form is included in Appendix E of this standard.

### The Principles of **UNIVERSAL DESIGN**

#### **1. EQUITABLE USE:**

The design is useful and marketable to people with diverse abilities.

#### **2. FLEXIBILITY IN USE:**

The design accommodates a wide range of individual preferences and abilities.

#### **3. SIMPLE AND INTUITIVE USE:**

Use of the design is easy to understand, regardless of the user's experience, knowledge, language skills, or current concentration level.

#### **4. PERCEPTIBLE INFORMATION:**

The design communicates necessary information effectively to the user, regardless of ambient conditions or the user's sensory abilities.

#### **5. TOLERANCE FOR ERROR:**

The design minimizes hazards and the adverse consequences of accidental or unintended actions.

#### **6. LOW PHYSICAL EFFORT:**

The design can be used efficiently and comfortably with a minimum of fatigue.

#### **7. SIZE AND SPACE FOR APPROACH AND USE:**

Appropriate size and space are provided for approach, reach, manipulation and use, regardless of user's body position, size, posture or mobility.

## 2.0 GLOSSARY AND DEFINITIONS

### GRAPHIC CONVENTIONS

Dimensions that are not marked maximum or minimum are absolute, unless otherwise indicated.

### GENERAL TERMINOLOGY

**comply with** Meet one or more specifications of this standard.

**if ... then** Denotes a specification that applies only when the conditions described are present.

**may** Denotes an option or alternative.

**shall** Denotes a mandatory specification or requirement.

**should** Denotes an advisory specification or recommendation.

### DEFINITIONS

**Access aisle**: An *accessible* pedestrian *space* between *elements*, such as parking *spaces*, seating and desks, which provides clearances appropriate for the use of the *elements*.

**Accessible**: Describes a *site*, *building*, *facility* or portion thereof that complies with this standard.

**Accessible element**: An *element* specified by this standard (for example, telephone, controls etc.).

**Accessible route**: A continuous unobstructed path connecting *accessible elements* and *spaces* of a *facility*. Interior *accessible routes* may include corridors, floors, *ramps*, elevators, platform lifts and *clear floor spaces* at fixtures. Exterior *accessible routes* may include parking *access aisles*, *curb ramps*, crosswalks at *vehicular ways*, *walkways*, *ramps* and platform lifts.

**Accessible space**: *Space* that complies with this standard.

**Accessible parking permit**: A valid permit issued by the Minister of Transportation under section 26 of the Highway Traffic Act or a valid permit, license plate or other marker or device bearing the International Symbol of Access issued by a jurisdiction other than Ontario.

**Accessible parking space**: A designated parking space identified by prescribed signage and pavement markings, which is reserved for the exclusive use of persons with an accessible parking permit.

**Adaptable**: The ability of a certain *building space* or *element*, such as kitchen counters, sinks, and grab bars, to be added or altered so as to accommodate the needs of individuals with or without *disabilities* or to accommodate the needs of persons with different types or degrees of *disabilities*.

**Adaptable Seating**: A fixed seat in an assembly occupancy located adjacent to an *access aisle* with a removable, foldable or no armrest to allow a person to transfer from one side into the fixed seating area from the *access aisle*.

**Addition**: An expansion, extension, or increase in the gross floor area of a *facility*.

**Alteration:** A change to a *facility* that affects or could affect the usability of the *facility* or part thereof. *Alterations* include, but are not limited to, remodeling, renovation, retrofitting, rehabilitation, reconstruction, historic restoration, resurfacing of *circulation paths* or *vehicular ways*, changes or rearrangement of the structural parts or *elements*, and changes or rearrangement in the plan configuration of walls and full-height partitions. Minor renovations, normal maintenance, painting or wallpapering, or changes to mechanical or electrical systems are not *alterations*, unless they affect the usability of the *building*.

**Alternative Experience:** A means of providing information about a *heritage facility* or a *public heritage facility*, when it is not feasible to make all or portions of the facility physically *accessible*. Alternative experience may include, but will not be limited to, video tours, displays, and publications.

**Amenities:** Items that provide conveniences or services for use by the public, examples of which include, but are not limited to, drinking fountains, benches and garbage receptacles.

**Area of refuge:** An area which has direct access to an exit, where people who are unable to use stairs may remain temporarily in safety to await further instructions or assistance during emergency evacuation.

**Assembly area:** The occupancy or the use of a building or part of a building by a gathering of persons for civic, political, travel, religious, social, educational, recreational or similar purposes or for the consumption of food or drink.

**Assistive Device:** A technical aid, communication device or other instrument that is used to maintain or improve the functional abilities of people with disabilities.

**Attic or Roof space:** The space between the roof and the ceiling of the top storey or between a dwarf wall and a sloping roof.

**Automatic door:** A door equipped with a power-operated mechanism and controls that open and close the door automatically upon receipt of a momentary actuating signal. The switch that begins the automatic cycle may be a photoelectric device, floor mat, or manual switch. (See *Power-assisted door*)

**Beach Access Routes:** Routes that are constructed and are intended for pedestrian use by the public and that provide access from off-street parking facilities, *recreational trails*, exterior paths of travel or *amenities* to an area of a beach that is intended for recreational use by the public.

**Bevel:** A small slope on the edge of a surface that helps an individual negotiate an elevation change.

**Board room or Conference room or Meeting room:** A room used for meetings, which accommodates six or more people.

**Boarding Pier:** A portion of a pier where a boat is temporarily secured for the purpose of embarking or disembarking.

**Boat Launch Ramp:** A sloped surface designed for launching and retrieving trailered boats and other water craft to and from a body of water.

**Boat Slip:** That portion of a pier, main pier, finger pier, or float where a boat is moored for the purpose of berthing, embarking, or disembarking.

**Building:** A structure occupying an area greater than ten square metres, consisting of a wall, roof and floor or any of them, or a structural system serving the function thereof, including all plumbing, fixtures and service systems appurtenant thereto; or a structure occupying an area of ten square metres or less that contains plumbing, including the plumbing appurtenant thereto; or structures designated in the Ontario Building Code.

**Circulation path:** An exterior or interior way of passage from one place to another for pedestrians, including, but not limited to *walkways*, hallways, courtyards, stairways, and stair landings.

**Clear:** Unobstructed.

**Clear floor space:** The minimum unobstructed floor or ground *space* required to accommodate a single, stationary wheelchair, scooter or other mobility device, including the user.

**Closed-circuit telephone:** A telephone with dedicated line(s), such as a house phone, courtesy phone or phone that must be used to gain entrance to a *facility*.

**Common use:** Refers to those interior and exterior rooms, *spaces* or *elements* that are made available for the use of a restricted group of people (for example, occupants of a homeless shelter, the occupants of an office *building*, or the guests of such occupants).

**Colour contrast:** The degree of difference between one colour and another; the more visually different the colours, the greater the contrast. Refer to Appendix C for more information. All references to colour contrast in this document shall be measured at 70% or greater.

**Cross slope:** The slope that is perpendicular to the direction of travel. (See *running slope*)

**Curb ramp:** A short ramp cutting through a curb or built up to a curb.

**Dynamic Symbol of Access:** Replaces the international symbol of access (where applicable) with a new symbol that portrays persons with disabilities as able, forward-moving, and as a distinct entity from the rest of the wheelchair.

**Depressed curb:** A continuous area where a curb or sidewalk is lowered to the same level as the adjacent roadway, resulting in a seamless transition between a pedestrian walkway and a vehicular route.

**Detectable warning:** A standardized surface feature built into or applied to walking surfaces or other elements to warn persons with a visual impairment of hazards on a circulation path, within a site.

**Disability:** Any restriction or lack of ability to perform an activity in the manner or within the range considered normal for a human being.

**Egress, Means of:** A continuous and unobstructed way of exit travel from any point in a facility to a public way. A means of egress comprises vertical and horizontal travel and may include intervening

room spaces, doorways, hallways, corridors, passageways, balconies, ramps, stairs, enclosures, lobbies, horizontal exits, courts and yards.

An accessible means of egress is one that complies with this standard and does not include stairs, steps or escalators. Areas of rescue assistance, protected lobbies or protected elevators may be included as part of an accessible means of egress.

**Element:** An architectural or mechanical component of a building, facility, space or site (e.g., telephone, curb ramp, door, drinking fountain, seating or water closet).

**Entrance:** Any access point into a building or facility used for the purposes of entering. An entrance includes the approach walk, the vertical access leading to the entrance platform, the entrance platform itself, vestibules (if provided), the entry door(s) or gate(s), and the hardware of the entry door(s) or gate(s).

**Elevated Play Component:** A play component that is approached above or below grade and that is part of a composite play structure consisting of two or more play components attached or functionally linked to create an integrated unit providing more than one play activity.

**Environmental Mitigation:** Activities that are intended to reduce, mitigate, prevent or compensate for adverse effects of human activities or items, including paths, play spaces, trails and parking, upon fish, wildlife, plants, invertebrates, *species at risk*, ecological integrity or natural heritage values.

**Environmental Restoration:** Activities that are intended to benefit fish, wildlife, plants, invertebrates, *species at risk*, ecological integrity or natural heritage values.

**Facility or Facilities:** All or any portion of buildings, structures, site improvements, complexes, roads, walkways, passageways, parks, parking lots or other real property located within the property lines of a site.

**Gangway:** A variable sloped pedestrian *walkway* that links a fixed structure or land with a floating structure. Gangways which connect to vessels are not included.

**Ground floor:** Any occupiable floor less than one storey above or below grade with direct access to grade. A facility always has at least one ground floor and may have more than one ground floor, as where a split-level entrance has been provided or where a facility is built into a hillside.

**Ground Level Play Component:** A play component that is approached and exited at the ground level.

**Guard:** A protective barrier, with or without openings through it, that is around openings in floors or at the open sides of stairs, landings, balconies, *mezzanines*, galleries, raised *walkways* or other locations to prevent accidental falls from one level to another.

**Handrail:** A component which is normally grasped by hand for support at stairways and other places where needed for the safety of pedestrians.

**Heritage Facility:** A facility located on a property, or portions thereof, that has been designated under the Ontario Heritage Act, or identified in the Heritage Properties Register of the City of Kingston. (See *Public Heritage Facility*)

**Impairment:** Any loss or abnormality of psychological, physiological or anatomical structure or function.

**Maintenance:** Activities that are intended to keep existing public *spaces* and *elements* in existing public *spaces* in good working order or to restore the *spaces* or *elements* to their original condition, examples of which include painting and minor repairs.

**Marked crossing:** A crosswalk or other identified path intended for pedestrian use in crossing a vehicular way.

**Mezzanine:** An intermediate floor assembly between the floor and ceiling of any room or *storey* and includes an interior balcony.

**Mobility Assistive Device:** A *mobility assistive device* as defined in section 2 of Ontario Regulation 191/11 (Integrated Accessibility standards) made under the *Accessibility for Ontarians with Disabilities Act, 2005*.

**Occupiable:** The use or intended use of a *building* or part of a *building* for the shelter or support of persons, animals or property in which individuals congregate for amusement, educational or similar purposes, or in which occupants are engaged at labour, and which is equipped with means of egress, light and ventilation.

**Obligated Organization:** These include the Government of Ontario, the Legislative Assembly, a designated public sector organization, a large organization and a small organization to which the standards in the AODA's Integrated Accessibility Standards Regulation apply.

**Open space:** Large-scale tracts of land without visible evidence of residential, commercial or industrial development. These areas may be privately or publicly owned and are generally left in a natural state and not programmed for active recreation. The benefits of open lands typically extend beyond the immediate area and usually provide community-wide benefits.

**Operable portion:** A part of a piece of equipment or appliance used to insert or withdraw objects, or to activate, deactivate, or adjust the equipment or appliance (for example, coin slot, push button, handle).

**Path of travel:** A continuous, unobstructed way of pedestrian passage, including but not limited to *walkways* and *sidewalks*, curb ramps and other interior or exterior pedestrian ramps, clear floor *paths* through lobbies, corridors, rooms, parking access aisles, elevators and lifts, or a combination of these elements.

**Park:** Land that is privately or publicly held that has been developed for multiple recreational and leisure-time uses. This land benefits the entire community and balances the demands of the public for

outdoor recreational facilities and other *amenities*, such as *recreational trails*, picnic areas, playgrounds, water features, *spaces* for free play and leisure.

**Play Area**: A portion of a site containing integrated play components.

**Power-assisted door**: A door used for human passage that has a mechanism that helps to open the door or relieves the opening resistance of a door, upon the activation of a switch or a continued force applied to the door itself.

**Private open space**: Privately owned land areas within a subdivision, generally smaller in scale than open space, which have been left free from structures, parking lots and roads. These types of areas generally benefit only the residents or employees of the particular subdivision and usually remain in private ownership.

**Public Heritage Facility**: A facility located on a property or portions thereof, that has been designated under the Ontario Heritage Act, or identified in the Heritage Properties Register of the City of Kingston, and that is open and accessible to the public. (See *Heritage Facility*)

**Public use**: Describes interior or exterior rooms or spaces that are made available to the general public. Public use may be provided at a facility that is privately or publicly owned.

**Ramp**: A walking surface which has a running slope greater than 1:25 (4%) for interior applications or 1:20 (5%) for exterior applications unless otherwise excepted within FADS.

**Recreational Trails**: Public pedestrian trails that are intended for recreational and leisure purposes, excluding the following: trails solely intended for cross-country skiing, mountain biking, or the use of motorized snow vehicles or off-road vehicles, wilderness and backcountry trails, and portage routes.

**Redeveloped**: Planned significant *alterations* to public *spaces*, but does not include *maintenance* activities, *environmental mitigation* or *environmental restoration*.

**Retrofit**: See alteration.

**Running slope**: The slope that is parallel to the direction of travel. (See *Cross slope*)

**Service entrance**: An *entrance* intended primarily for delivery of goods or services and not intended for use by the public.

**Service room**: A room provided in a *building* to contain equipment associated with *building* services.

**Service space**: A space provided in a *facility* to facilitate or conceal the installation of *facility* service *facilities* such as chutes, ducts, pipes, shafts or wires.

**Signage**: Displayed verbal, symbolic, *tactile* and pictorial information.

**Site**: A parcel of land bounded by property lines or a designated portion of a public right-of-way.

**Site improvement**: Landscaping, paving for pedestrian and *vehicular ways*, outdoor lighting, recreational *facilities* added to a *site*.



**Sleeping accommodations:** Rooms in which people sleep, for example, a dormitory.

**Slope:** the ratio of the vertical dimension (rise) over the horizontal dimension (run) . Percent grade is in parentheses.

**Space:** A definable area (e.g. room, toilet room, hall, *assembly area*, *entrance*, storage room, alcove, courtyard or lobby).

**Species at Risk:** A species listed in Schedules 1, 2, 3 or 4 to Ontario Regulation 230/08 (Species at Risk in Ontario List) made under the Endangered Species Act, 2007.

**Storey:** That portion of a *building* included between the upper surface of a floor and the upper surface of the floor next above. If such portion of a *building* does not include *occupiable space*, it is not considered a *storey* for the purposes of this standard. There may be more than one floor level within a *storey*, as in the case of a *mezzanine* or *mezzanines*.

**Structural frame:** The columns and the girders, beams, trusses and spandrels having direct connection to the columns and all other members which are essential to the stability of the *building* as a whole.

**TDD** (Telecommunication Device for the Deaf): See *Text telephone*.

**TTY** (Teletypewriter): See *Text telephone*.

**Tactile:** Describes an object that can be perceived using the sense of touch.

**Technically infeasible:** Means, with respect to an *alteration* of a *building* or a *facility* that it has little likelihood of being accomplished, because:

- existing structural conditions would require moving or altering a load-bearing member which is an essential part of the *structural frame*; or
- other existing physical or *site* constraints prohibit modification or addition of necessary *elements*, *spaces* or features that are in full and strict compliance with the minimum requirements for new construction.

See Appendix E and F for more information on the process to gain assistance in determining if alteration of an element is technically infeasible.

**Temporary structure:** A *facility* that is not of permanent construction but that is extensively used, or is essential for *public use* for a period of time. Examples of temporary *facilities* covered by this standard include, but are not limited to, reviewing stands, bleacher areas, temporary kiosks, temporary health screening services or temporary safe pedestrian passageways around a construction *site*. Structures and equipment directly associated with the actual processes of construction, such as scaffolding, bridging, materials hoists, or construction trailers, are not included.

**Text telephone (TTY):** Machinery or equipment that employs interactive text-based communication through the transmission of coded signals across the standard telephone network. *Text telephones* can include, for example, devices known as *TDDs* (telecommunication display devices or

telecommunication devices for deaf persons) or computers with special modems. *Text telephones* are also called *TTYs*, an abbreviation for teletypewriter.

**Vehicular way**: A route intended for vehicular traffic, such as a street, driveway or parking lot, within the boundary of the *site*.

**Vibro-Tactile Walk Indicators**: means pedestrian crossing signal push button devices that vibrate and can be felt through the sense of touch to communicate pedestrian crossing timing in a non-visual way.

**Visitable**: The ability of a dwelling unit to offer a reasonable level of access to accommodate visitors with *disabilities*, elderly persons or residents who may be temporarily disabled - allowing a person to enter safely, maneuver independently, and to utilize a toilet.

**Walkway**: An exterior pathway with a prepared surface intended for pedestrian use, including general pedestrian areas, such as plazas and courts, within the boundary of the *site*.

**Wayfinding**: A term that describes the spatial problem-solving process that a person uses to reach a destination. See Appendix B.

## 3.0 SCOPE AND APPLICATION

### SCOPE

The requirements of this standard shall be

- mandatory for all newly constructed and retrofitted facilities owned, leased or operated by the City of Kingston; and
- encouraged for all other facilities, whether new or retrofitted.

Exceptions: The design requirements of this standard do not apply to

- *buildings* of Group F Division 1 occupancy, as defined by the Ontario Building Code (latest edition with all amendments);
- *buildings* which are not intended to be occupied on a daily or full-time basis, including, but not limited to, automatic telephone exchanges, service rooms, elevator machine rooms, janitor rooms, service spaces, crawl spaces, and attic or roof spaces;
- exterior paths of travel in the public right of way, which shall meet the requirements of the Integrated Accessibility Standards (O.Reg. 191/11); and
- facilities operated by Utilities Kingston that are not open to the public for independent access and visitation, including, but not limited to, water treatment plants, sewage waste water treatment plants, water booster stations, sewage pumping stations, or gas regulating stations (note: this exemption does not include administrative offices).

### GENERAL APPLICATION

All areas of newly designed or newly constructed *facilities* and altered portions of existing *facilities* shall comply with Sections 4.1 to 4.4 of this standard, unless otherwise provided in this section or as modified in Section 4.5, Facility-Specific Requirements.

All City staff, contracted consultants and builders will be responsible for the application of FADS and this standard will be referenced in request for proposals, tenders, and build contracts. Responsibility for implementation will be department Directors in consultation with the staff person assigned to ensure implementation of Provincial Accessibility regulations.

### APPLICATION BASED ON FACILITY USE

In addition to all of the provisions specified in Sections 4.1 to 4.4 of this document, the specific facility types listed in Section 4.5 must comply with the design requirements specified in Section 4.5.

Where a *facility* contains more than one use covered by a special application section, each portion must comply with the requirements for that section, in addition to all other general provisions.

### WORK AREAS AND EMPLOYEE-DESIGNATED AREAS

All *facilities* shall be *accessible* for employees, as well as patrons/ users. All areas intended for use by employees shall be designed and constructed to comply with the requirements of this document, unless otherwise exempted in Section 3.0.

**TEMPORARY FACILITIES**

The requirements of this document apply to temporary *facilities*, as well as permanent *facilities*.

**RETROFITTING, ALTERATIONS & ADDITIONS**

An addition to an existing *facility* shall be regarded as a major *alteration*.

Each new space or *element* added to the existing *facility* shall comply with the applicable provisions of this document.

Except where the provision of *accessible* features is technically infeasible, no *alteration* will decrease or have the effect of decreasing accessibility or usability of an existing *facility* to below the requirements of new construction at the time of *alteration*.

If existing *elements*, *spaces*, or common areas are altered, then each such altered *element/space/feature/ area* shall comply with all applicable provisions. If the applicable provision for new construction requires that an *element/space/feature/area* be on an *accessible* route and the altered *element/space/feature/area* is not on an *accessible* route, this route must be altered to become *accessible*.

Upgrades and changes to existing *elements* must be relevant to the *alteration* being undertaken. For example, altering a washroom in an existing *facility* to make it *accessible* will not automatically require all parts of the existing *facility* to be retrofitted at the same time.

If *alterations* of single *elements*, when considered together, amount to a major *alteration* of a room or *space* in a *facility*, then the entire *space* must be made *accessible*.

No *alteration* of an existing *element*, *space*, or area of a *facility* will impose a requirement for greater accessibility than that which would be required for new construction.

If an escalator or stairs are proposed as a means of access where none existed previously, and major structural modifications are necessary for such installations, then a means of *accessible* access must also be provided.

If a planned *alteration* entails *alterations* to an entrance, and the *facility* already has an *accessible* entrance, the entrance being altered is also required to be *accessible*.

If the *alteration* work is limited solely to the electrical, mechanical or plumbing system, or to hazardous material abatement, or to automatic sprinkler retrofitting, and does not involve the *alteration* of any *elements* or *spaces* required to be *accessible* under these guidelines, then the requirements of this document do not apply (except for alarms, public telephones, and assistive listening systems).

An *alteration* that affects the usability of, or access to, an area containing a primary function must be made to ensure that, to the maximum extent feasible, the *path of travel* to the altered area and the restrooms, telephones and drinking fountains serving the altered area are readily *accessible* to and usable by individuals with disabilities.

Where the provision of *accessible* features is technically infeasible, and the requirements of this document allow a reduction of maneuvering *space* from the standards for new construction, the reduced dimensions are to be considered minimums. Wherever possible, larger maneuvering *spaces* must be provided.

## **HERITAGE FACILITIES**

The requirements of this standard will apply to *alterations* to a *Heritage Facility*, however, under the Ontario Human Rights Code, there are allowances for modification to the defining features of a *Heritage Facility* which are deemed to alter the essential nature or substantially affect the viability of the enterprise.

*Public Heritage Facilities* should be assessed for compliance to accessibility standards on an individual basis, to determine the most effective and least disruptive means of *retrofit*, where required.

Alterations to a Heritage Facility may require approvals pursuant to the Ontario Heritage Act. Accordingly, proponents subject to this standard are asked to consult with the City's heritage staff when considering alterations to a Heritage Facility and prior to undertaking any works.

## **EXCEPTIONS, GENERAL**

Exceptions to the requirements within this document are permitted where *obligated organizations* can demonstrate one or more of the following:

1. The requirements, or some of them, would likely affect the cultural heritage value or interest of a property identified, designated or otherwise protected under the Ontario Heritage Act as being of cultural heritage value or interest.
2. The requirements, or some of them, would affect the preservation of places set apart as National Historic Sites of Canada by the Minister of the Environment for Canada under the Canada National Parks Act (Canada)
3. The requirements, or some of them, would affect the national historic interest or significance of historic places marked or commemorated under the Historic Sites and Monuments Act (Canada).
4. The requirements, or some of them, might damage, directly or indirectly, the cultural heritage or natural heritage on a property included in the United Nations Educational, Scientific and Cultural Organisation's World Heritage List of sites under the Convention Concerning the Protection of the World Cultural and Natural Heritage.
5. There is a significant risk that the requirements, or some of them, would adversely affect water, fish, wildlife, plants, invertebrates, *species at risk*, ecological integrity or natural heritage values, whether the adverse effects are direct or indirect.
6. It is not practicable to comply with the requirements, or some of them, because existing physical or *site* constraints prohibit modification or *addition* of *elements*, *spaces* or features, such as where surrounding rocks bordering the recreational trail or *beach access route* impede achieving the required *clear* width.

## EXCEPTIONS, LIMITATIONS

Where an exception is permitted to a requirement, the exception applies solely,

(a) to the particular requirement for which the exception is allowed and not to any other requirement that applies to the recreational trail or *beach access route*; and

(b) to the portion of the recreational trail or *beach access route* for which it is claimed and not to the recreational trail or *beach access route* in its entirety

## ALTERNATE ACCOMMODATIONS

In a retrofit situation where the requirements of a section of this document are *technically infeasible* to implement, alternate accommodations may be proposed. Alternate accommodation proposals must be referred by the City of Kingston for review and approval on an individual basis using the Alternate Design Review Process outlined in Appendix F. Refer also to the Technical Infeasibility Justification Form in Appendix E and Equivalent Facilitation Proposal Form included in Appendix G, as well as Section 5.0 - Implementation and Enforcement.

## IMPLEMENTATION

Accessibility staff of the City of Kingston, other City departments, as well as contracted consulting firms, will be responsible for the application of the Facility Accessibility Design Standards when designing, reviewing, and administering all construction projects associated with new municipal *facilities*, as well as all major *alterations* to existing *facilities* owned, leased, or operated by the City of Kingston.

Designing and constructing to this standard shall be included as a mandatory requirement in all City of Kingston Request for Proposals, Tender Documents and construction Contracts.

## ENFORCEMENT

Accessibility staff of the City of Kingston and other City departments, through the applicable project manager, will ensure compliance to this standard during the pre- planning, design, construction documents preparation, and contracts administration phases.

## 4.0 DESIGN STANDARDS

All areas of newly designed or constructed *facilities*, or existing *facilities* that will be undergoing major *alterations*, must comply with this section, unless otherwise exempted in Section 3.0.

The requirements of this section do not apply to the following spaces or facilities:

- Buildings of Group F Division 1 occupancy (high hazard industrial occupancy), as defined by the Ontario Building Code (latest edition with all amendments);
- Facilities operated by Utilities Kingston that are not open to the public for independent access and visitation, including, but not limited to, water treatment plants, sewage waste water treatment plants, water booster stations, sewage pumping stations, or gas regulating stations (note: this exemption does not include administrative offices); and,
- Facilities that are not intended to be occupied on a daily or full-time basis, including, but not limited to, automatic telephone exchanges, service rooms, elevator machine rooms, janitor rooms, service spaces, crawl spaces, and attic or roof spaces.

The requirements of this section apply to all areas of a facility except

- service rooms
- elevator machine rooms
- janitor rooms
- service spaces
- crawl spaces
- attic or roof spaces

The design elements in these standards are organized by: Access and Circulation; Washroom Facilities; Other Amenities; Systems and Controls; and Facility-Specific Requirements.

## 4.1 ACCESS AND CIRCULATION

### 4.1.1 SPACE AND REACH REQUIREMENTS

#### RATIONALE

The dimensions and maneuvering characteristics of wheelchairs, scooters and other mobility devices are as varied as the people who use them. Traditionally, accessibility standards have taken a conservative approach to wheelchair maneuverability, reflecting the needs of a physically strong individual using a manual wheelchair. Such an approach excludes the many users without such a degree of strength or those using a larger mobility device. This standard more accurately reflects the vast array of equipment that is used by persons to access and use facilities, as well as the diverse range of user ability. This standard incorporates more generous *space* requirements, particularly related to the dynamic movement of people using wheelchairs, scooters or other *mobility assistive devices*.

#### APPLICATION

*Space* and reach range provisions for persons who use wheelchairs, scooters and other mobility devices shall comply with this section.

#### DESIGN REQUIREMENTS

The *space* required for a wheelchair to make a 360-degree turn is a *clear floor space* of 2440 mm (96-1/16 in.) in diameter, Figure 4.1.1.1 or for a 180-degree turn, as shown in Figure 4.1.1.2.

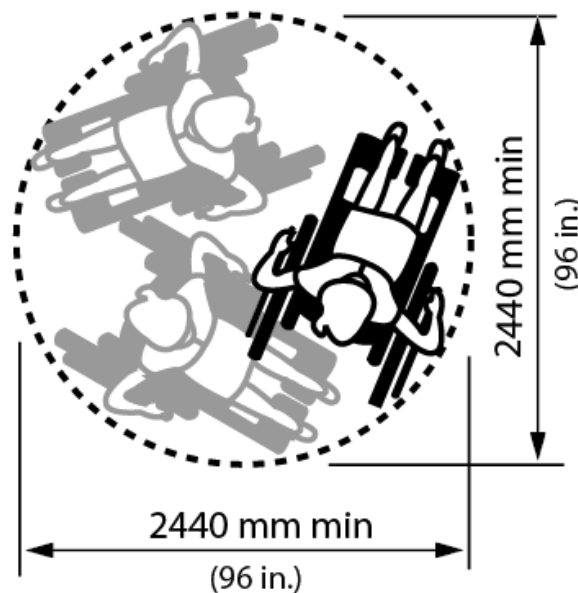
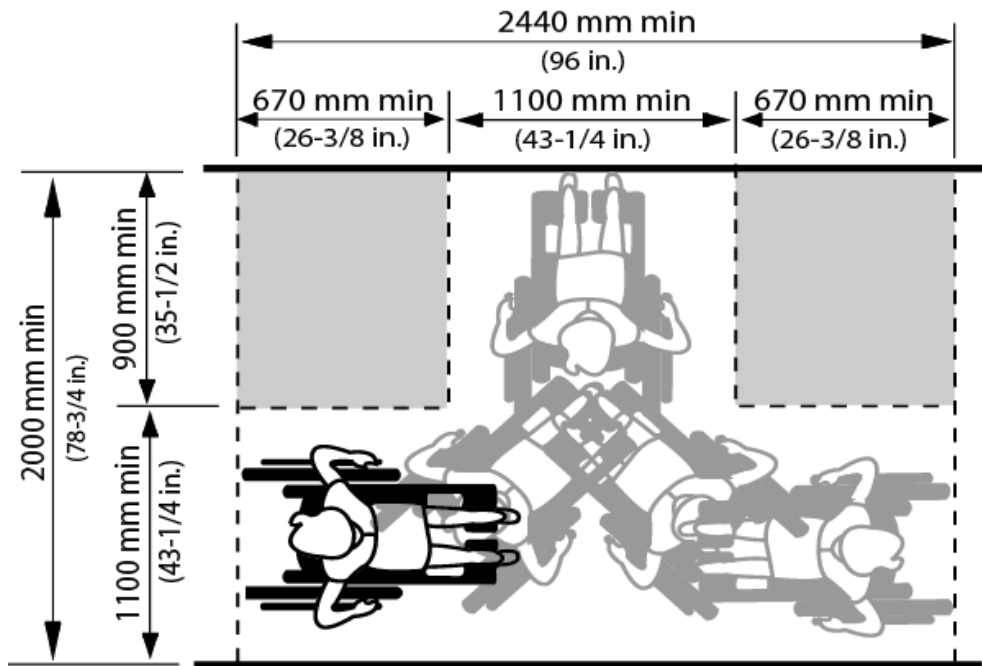


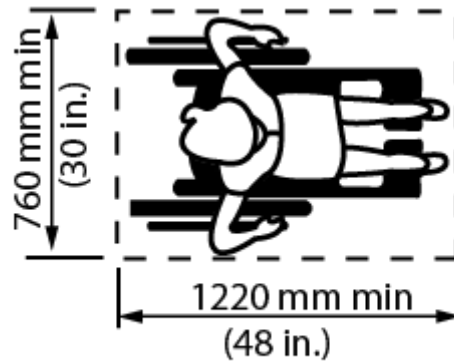
Figure 4.1.1.1 360 degree Turning Space



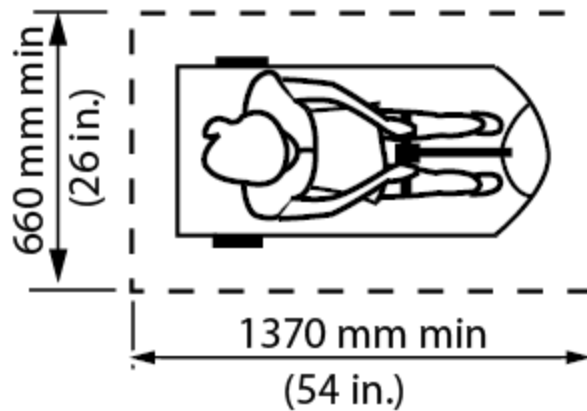


**Figure 4.1.1.2** 180 degree Turning Space

The minimum *clear floor space* or *ground space* necessary to accommodate the largest dimensional requirement of a single, stationary wheelchair or scooter and its occupant shall be 760 mm (30 in.) x 1370 mm (54 in.). (Refer to Figures 4.1.1.5 and 4.1.1.6)



**Figure 4.1.1.5** Clear Floor Space for Wheelchair

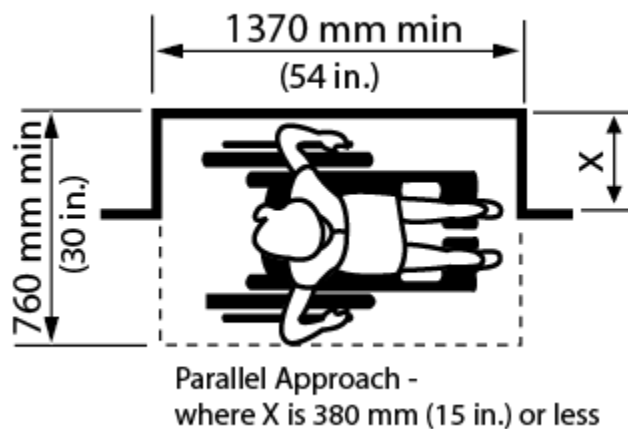


**Figure 4.1.1.6** Clear Floor Space for Scooter

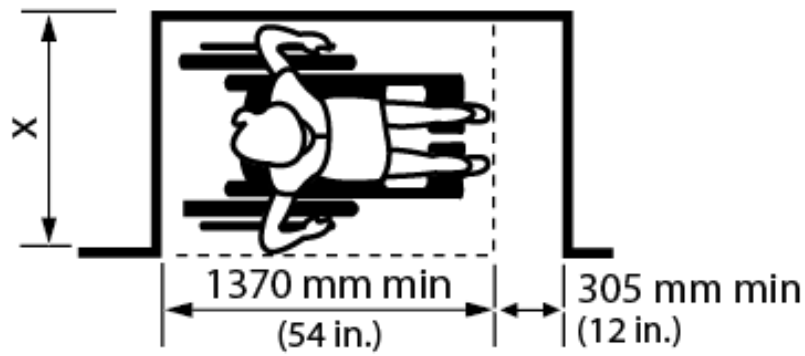
The minimum *clear floor space* or *ground space* for wheelchairs or scooters may be positioned for forward or parallel approach to an object.

*Clear floor space* or *ground space* for wheelchairs may be part of the *knee space* required under some objects.

One full, unobstructed side of the *clear floor space* or *ground space* for a wheelchair or scooter shall adjoin or overlap an *accessible route* or adjoin another wheelchair *clear floor space*. If a *clear floor space* is located in an alcove or otherwise confined on all or part of three sides, additional maneuvering clearances shall be provided as shown in Figures 4.1.1.3, 4.1.1.4, 4.1.1.7 and 4.1.1.8.

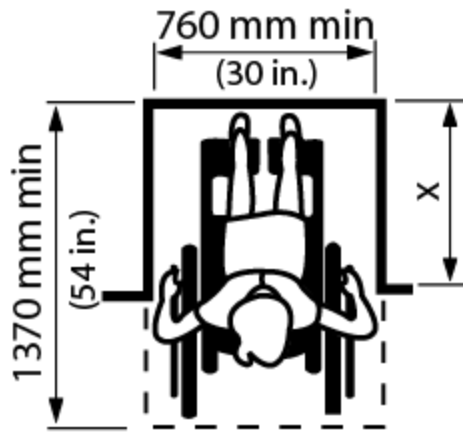


**Figure 4.1.1.3** Clearances at Alcove



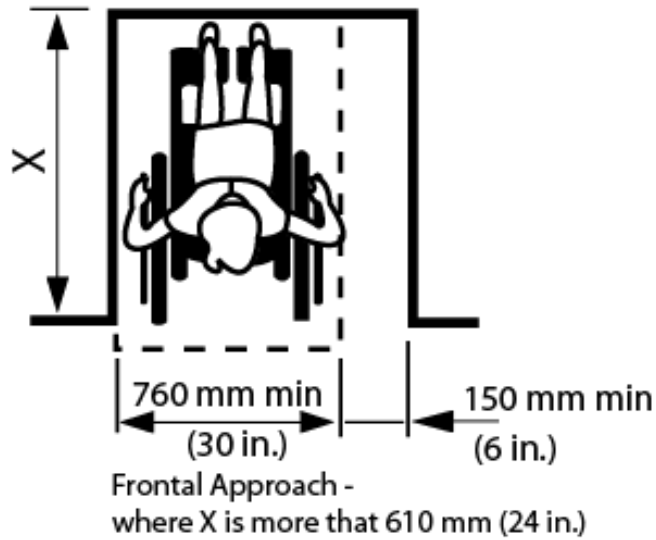
Parallel Approach -  
where X is more than 380 mm (15 in.)

**Figure 4.1.1.4** Clearances at Alcove



Frontal Approach -  
where X is 610 mm (24in.) or less

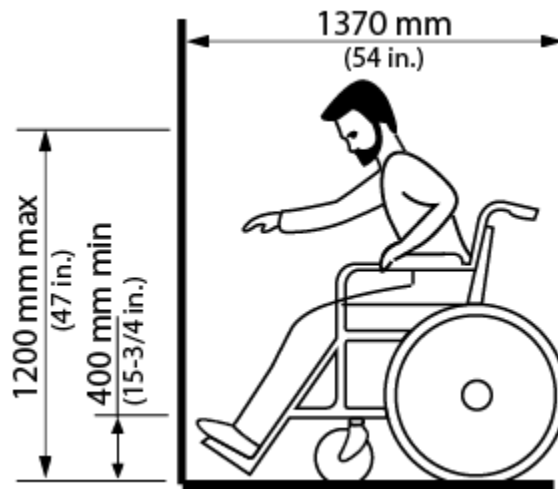
**Figure 4.1.1.7** Clearances at Alcove



**Figure 4.1.1.8** Clearances at Alcove

The surface of *clear* floor or ground *spaces* for wheelchairs and scooters shall comply with 4.1.2.

If the *clear floor space* only allows forward approach to an object, the maximum high forward reach allowed shall be 1200 mm (47-1/4 in.). The minimum low forward reach is 400 mm (15-3/4 in.). Refer to Figure 4.1.1.11. If the high forward reach is over an obstruction, reach and clearances shall be as shown in Figures 4.1.1.12 and 4.1.1.13.



**Figure 4.1.1.11** Forward Reach

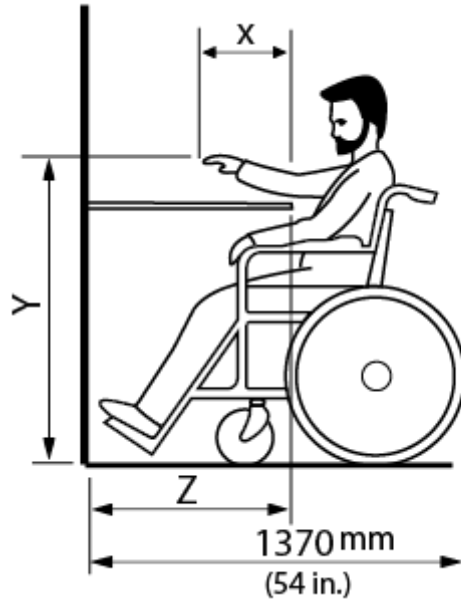


Figure 4.1.1.12 Forward Reach over an Obstruction

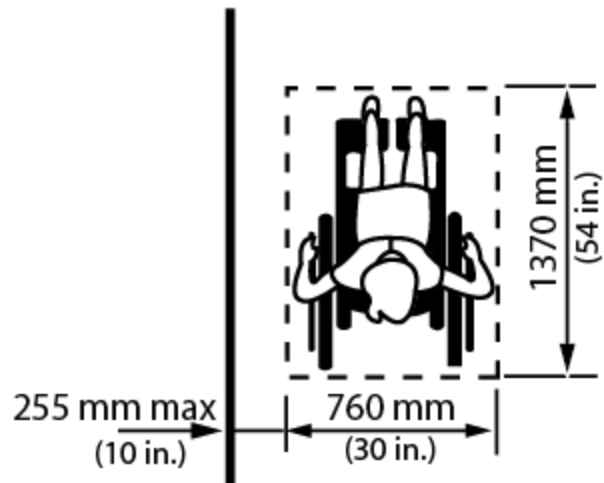
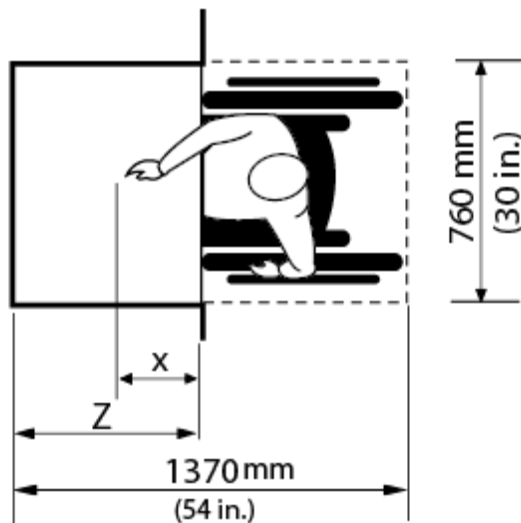


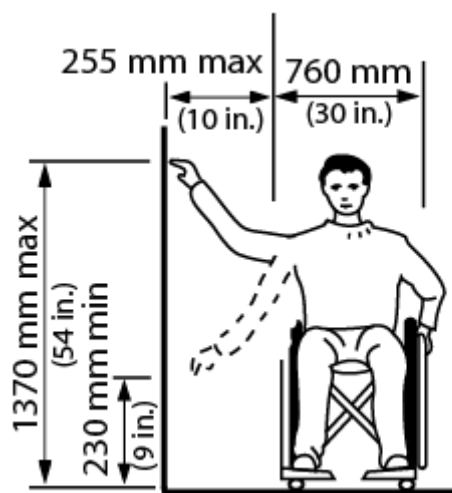
Figure 4.1.1.13 Side Reach - Maximum Distance to Wheelchair



**Figure 4.1.1.14** Forward Reach over an Obstruction

**NOTE:** In Diagrams 4.1.1.12 and 4.1.1.14, X shall be less than or equal to 635 mm (25 in.); Z shall be greater than or equal to X. When X is less than 510 mm (20 in.), then Y shall be 1220 mm (48 in.) maximum. When X is 510 to 635 mm (20 to 25 in.), then Y shall be 1120 mm (44 in.) maximum.

If the clear floor space allows parallel approach to an object, the maximum high side reach allowed shall be 1370 mm (54 in.) and the low side reach no less than 230 mm (9-1/16 in.) above the floor. Refer to Figure 4.1.1.9. If the side reach is over an obstruction, the reach and clearances shall be as shown in Figure 4.1.1.9 and 4.1.1.13. Notwithstanding these requirements, the Ontario Building Code requires thermostats and manual pull stations to be located 1200 mm (47 in.) above the finished floor, and in the case of all other controls for the operation of facility services or safety devices including electrical switches and intercom switches, they shall be mounted 900 mm (35 in.) to 1100 mm (44 in.) above the floor.



**Figure 4.1.1.9** Side Reach

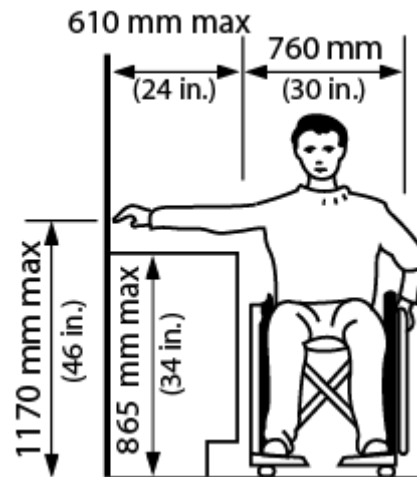


Figure 4.1.1.10 Side Reach over an Obstruction

## 4.1.2 GROUND AND FLOOR SURFACES

### RATIONALE

Design decisions related to ground and floor surfaces will influence every person who enters the building. Irregular surfaces, such as cobblestones or pea-gravel finished concrete, are difficult for both walking and pushing a wheelchair. Slippery surfaces are hazardous to all individuals and especially hazardous for seniors and others who may not be sure-footed.

Glare from polished floor surfaces can be uncomfortable for all users and can be a particular obstacle to persons with a visual *impairment* by obscuring important orientation and safety features. Pronounced *colour contrast* between walls and floor finishes may be helpful for persons with a visual *impairment*, as are changes in colour/texture where a change in level or function occurs.

Patterned floors should be avoided, as they can create visual confusion.

Thick pile carpeting makes pushing a wheelchair very difficult. Small and uneven changes in floor level represent a further barrier to using a wheelchair but also present a tripping hazard to ambulatory persons.

Openings in any ground or floor surface such as grates or grilles can catch canes or wheelchair wheels.

### APPLICATION

Ground and floor surfaces along all routes generally used by staff and public and within all areas generally used by staff and public shall comply with this section.

### DESIGN REQUIREMENTS

Ground and floor surfaces shall be stable, firm, slip resistant and glare-free.

Changes in level, except for elevators and other elevating devices, shall conform to Table 4.1.2.

| Table 4.1.2 Changes in Level       |  |
|------------------------------------|--|
| Vertical Rise                      | Edge Treatment   |
| 0 to 6 mm (0 – ¼ in.)              | May be vertical  |
| 6.1 mm to 13 mm (9/32 in. – ½ in.) | <i>Bevel</i> , Maximum slope 1:2 (50%)                   |
| Over 13 mm (over ½ in.)            | Treat as a sloped floor, <i>ramp</i> or <i>curb ramp</i> |

Table 4.1.2 Changes in level

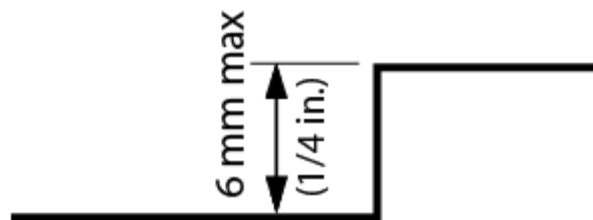


Figure 4.1.2.1a Changes in Level

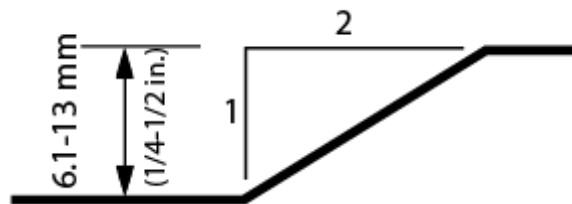


Figure 4.1.2.1b Changes in Level

Carpets or carpet tile shall:

- be securely fixed;
- be off-gassed prior to installation;
- have a firm cushion, pad or backing, where used;
- have a level loop, textured loop, level cut pile, or level cut/uncut pile texture with a maximum pad and pile height of 13 mm (1/2 in.); and
- have exposed edges fastened to floor surfaces with trim conforming to Table 4.1.2.

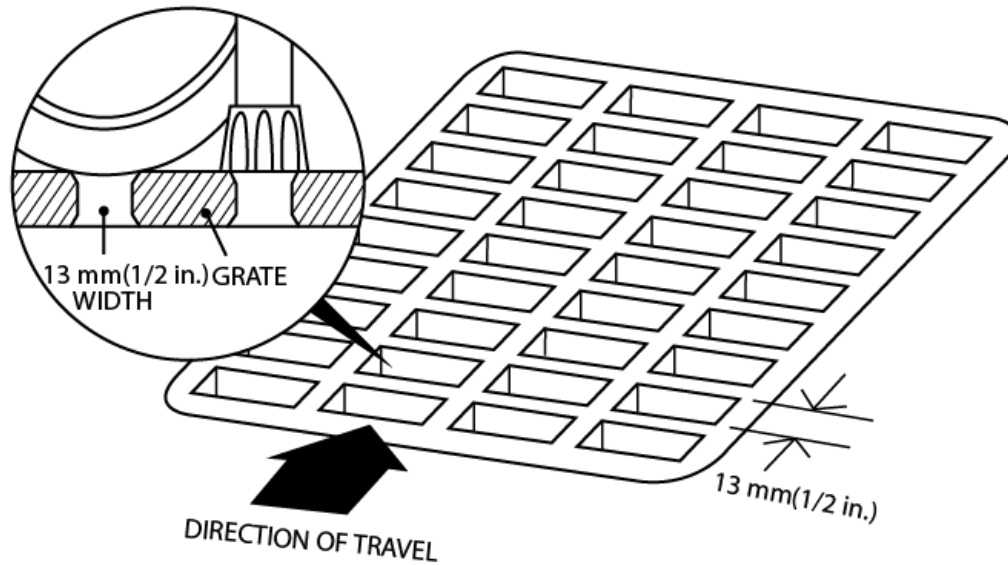
Floor mats should be *colour contrasted* from the surrounding surfaces, not exceed 13 mm (1/2 in.) in height, and, either have a beveled edge or be securely fixed or placed in a depression that is level with the surrounding floor area.

Gratings located in walking surfaces shall

- have spaces not greater than 13 mm (1/2 in.) wide in one direction; and
- be placed so that the long dimension is perpendicular to the dominant direction of travel.



OPENINGS LARGER THAN 13 mm (1/2 in.) MAY  
CATCH WHEELCHAIR WHEELS OR CANES



**Figure 4.1.2.2** Grills and Gratings

## RELATED SECTIONS

- 4.1.4 Accessible Routes, Paths and Corridors
- 4.4.8 Detectable Warning Surfaces
- 4.4.14 Materials and Finishes
- 4.4.15 Texture and Colour

## 4.1.3 PROTRUDING & OVERHEAD OBJECTS

### RATIONALE

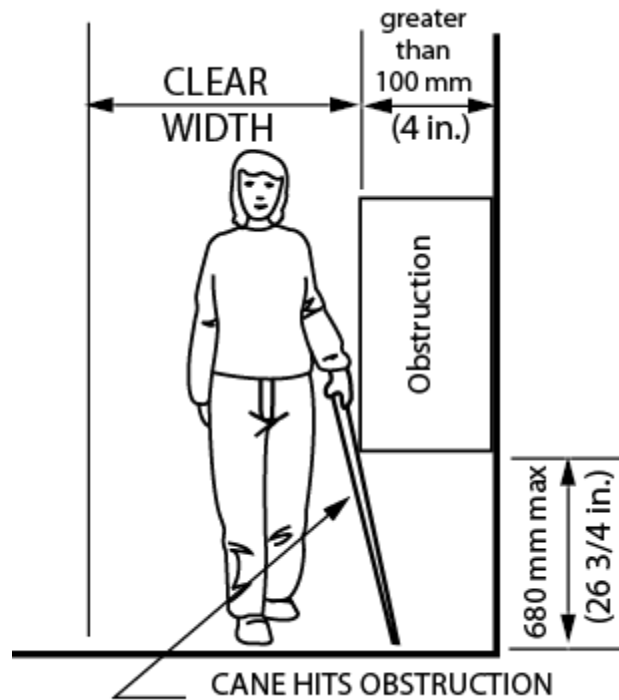
The creation of pathways free from protruding objects or freestanding obstacles is important to all *facility* users. An object protruding from a wall above the detection range of a cane is dangerous for persons with a visual *impairment* or a pedestrian distracted by a conversation. The underside of stairways is a common overhead hazard. Temporary construction barriers can also be hazardous if their lower edge is too high to be detected by a person using a long white cane for mobility. *Detectable warning surfaces* around freestanding obstacles, such as light standards, are advantageous to anyone using a pathway.

### APPLICATION

Protruding objects from a wall, ceiling or other location shall comply with this section.

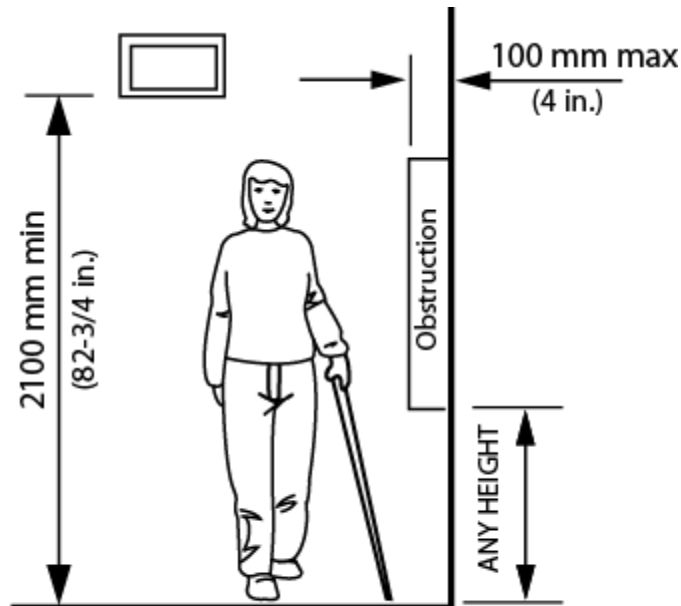
**DESIGN REQUIREMENTS**

Objects protruding from walls with their leading edges between 680 mm (26-3/4 in.) and 2100 mm (82-3/4 in.) from the floor shall protrude not more than 100 mm (3-15/16 in.) into pedestrian areas, such as walkways, halls, corridors, passageways or aisles.



**Figure 4.1.3.1** Limits of Protruding Objects between 680 and 2100 mm

Objects attached to a wall with their leading edges at or below 680 mm (26-3/4 in.) from the floor may protrude any amount.

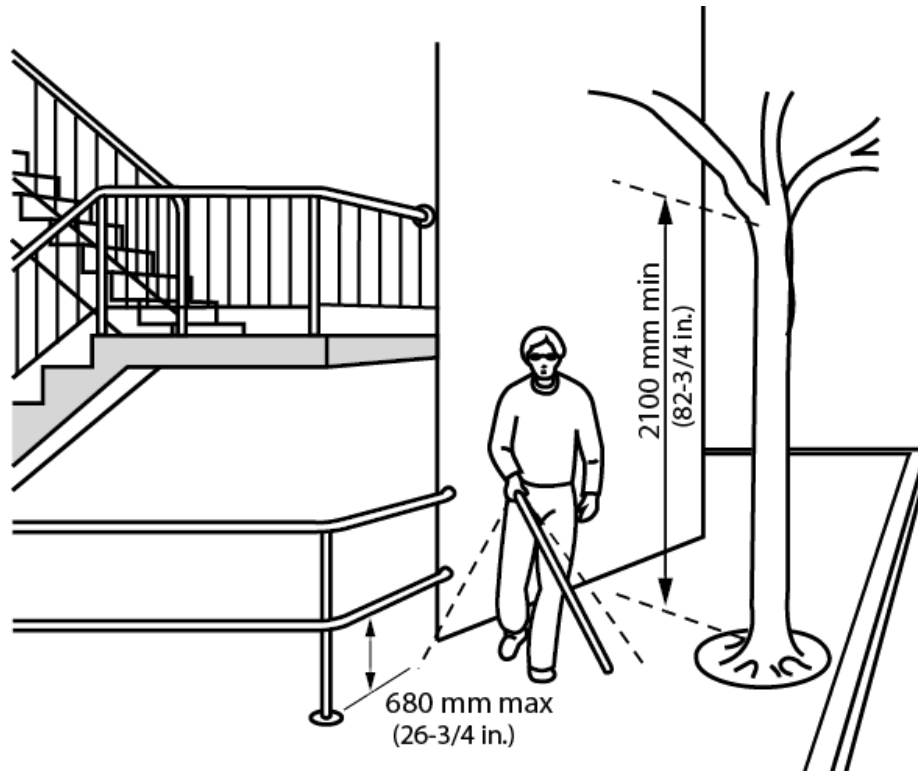


**Figure 4.1.3.2** Limits of Protruding Objects at or below 680 mm

Freestanding objects shall not have any overhang of more than 300 mm (11-3/4 inches) between 680 mm (26-3/4 inches) and 2100 mm (82-3/4 inches) from the ground to the floor.

The maximum height of the bottom edge of freestanding objects with a *space* of more than 300 mm (11-3/4 in.) between supports shall be 680 mm (26-3/4 in.) from the ground or floor.

Protruding objects shall not reduce the *clear* width required for an *accessible route* or maneuvering *space*.



**Figure 4.1.3.3** Overhead Obstructions

The minimum *clear* headroom in pedestrian areas, such as walkways, halls, corridors, passageways, or aisles, shall be 2100 mm (82-3/4 in.).

A detectable *guard*, guardrail or other barrier having its leading edge at or below 680 mm (26-3/4 in.) from the floor shall be provided where the headroom of an area adjoining an *accessible route* is less than 2100 mm (82-3/4 in.).

## RELATED SECTIONS

4.1.4 Accessible Routes, Paths and Corridors

4.4.8 Detectable Warning Surfaces

4.4.14 Materials and Finishes

4.4.15 Texture and Colour

## 4.1.4 ACCESSIBLE ROUTES, PATHS & CORRIDORS

### RATIONALE

Paths of travel through a facility should address the full range of individuals that may use them. They must provide the *clear* width necessary for persons using wheelchairs or scooters, those pushing strollers or those travelling in pairs. Consideration should be given not just to the width of items, such as wheelchairs and scooters, but also to their maneuverability. While a corridor may be wide enough

for a person to drive a scooter in a straight line, it may not be possible to make a turn around a corner. The preferred minimum width for *accessible routes* is 1830 mm (72 in.).

Strong *colour contrasts* and/or tactile pathways set into floors may be used to assist individuals with a visual *impairment* to negotiate an environment. Edge protection that guards a change in level is an important safety feature for all users.

## **APPLICATION**

Wherever possible, all routes, paths and corridors shall comply with this section.

At least one *accessible route* complying with this section shall be provided within the boundary of the *site* from *accessible parking spaces*, passenger-loading zones (if provided), and public streets or sidewalks to the *accessible facility entrance* they serve. The *accessible route* shall, to the maximum extent feasible, coincide with the route for the general public.

At least one *accessible route* shall connect *accessible buildings, facilities, elements* and *spaces* that are on the same *site*. It is preferable to have all routes *accessible*.

Except where essential obstructions in a work area would make an *accessible route* hazardous, an *accessible route* shall connect *accessible entrances* with all *accessible spaces* and *elements* within the *facility*. An *accessible route* complying with this section shall be provided within all normally *occupiable* floor areas. Exceptions: The provision of an *accessible route* does not apply

- to *service rooms*;
- to elevator machine rooms;
- to janitor rooms;
- to *service spaces*;
- to *crawl spaces*;
- to *attic* or *roof spaces*;
- to high-hazard industrial occupancies;
- within portions of a floor area with fixed seats in an *assembly occupancy* where these portions are not part of an *accessible route* to spaces designated for wheelchair use; or
- within a suite of *residential occupancy*.

Accessible routes are permitted to include *ramps, curb ramps*, stairs (alongside ramps), elevators or other elevating devices (as permitted in 4.1.15) where a difference in elevation exists.

A walkway or pedestrian bridge connecting two barrier-free storeys in different buildings shall form part of an accessible route and shall comply with this section.

## **DESIGN REQUIREMENTS**

The minimum *clear* width of an *accessible route* shall be 1100 mm (43-1/4 in.) except

- at doors - refer to 4.1.6;
- where additional maneuvering *space* is required at doorways (See 4.1.6);
- at U-turns around obstacles less than 1220 mm (48 in.) wide, it shall be 1220 mm (48 in.);

## Exhibit A

- for exterior paths (including walkways), which must have a minimum clear width of 1,500 mm (59 in.) – however, this clear width can be reduced to 1,220 mm (48 in.) to serve as a turning space where the exterior path connects with a curb ramp (refer to Figure 4.1.10.6);
- *barrier-free* paths of travel less than 1600 mm (63 in.) in width shall be provided with an unobstructed space not less than 1800 mm (71 in.) in width and 1800 mm (71 in.) in length located not more than 30 m (98 ft. 5 in.) apart; and
- at secondary circulation routes within open office areas, where systems-furniture work station clusters are used, it shall be 920 mm (36 in.).

Interior *accessible routes* shall

- have a *running slope* not steeper than 1:25 (4%); and
- have a *cross slope* not steeper than 1:50 (2%).

Exterior *accessible routes* shall

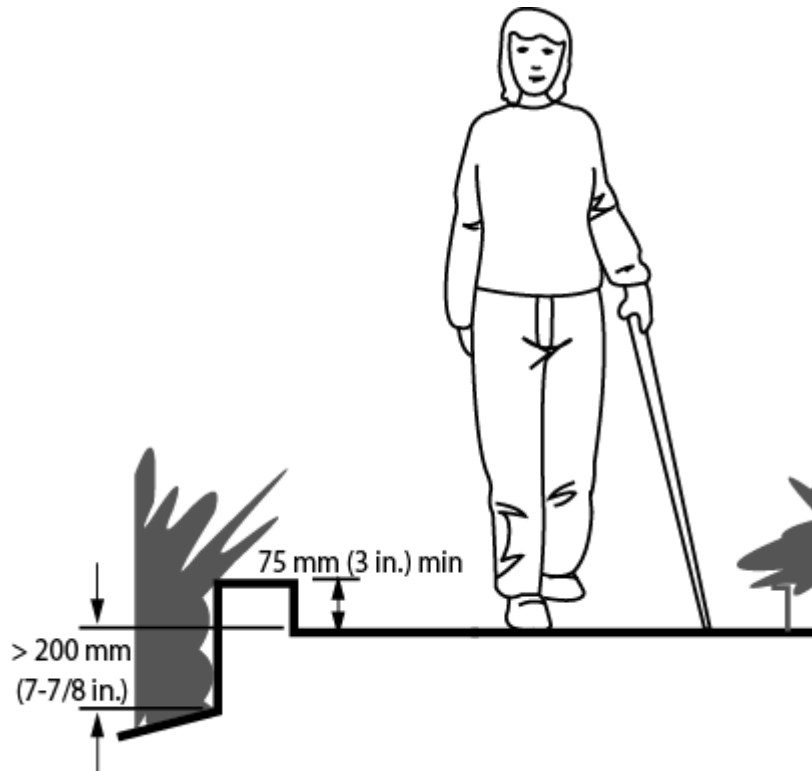
- have a maximum running slope of 1:20 (5%) – however, where the exterior path is a sidewalk, it can have a slope of greater than 1:20 (5%), but it cannot be steeper than the slope of the adjacent roadway; and
- have a maximum cross slope of 1:20 (5%) where the surface is asphalt, concrete or a similarly hard surface, or no more than 1:10 (10%) in all other cases.

*Curb ramps* along an *accessible route* shall be in compliance with 4.1.10.

Every *accessible route* less than 1830 mm (72 in.) wide shall be provided with an unobstructed passing space of not less than 1830 mm (72 in.) in width and 1830 mm (72 in.) in length, located not more than 30 meters (98 ft. 5 in.) apart.

Except at stairs and at elevated platforms such as performance areas or loading docks, where the edge(s) of an *accessible route*, path or corridor is not level with the adjacent surface, the edge(s) shall be protected

- by a *colour contrasting* curb of at least 75 mm (2-15/16 in.) high where the change in level is between 200 mm (7-7/8 in.) and 600 mm (23-5/8 in.); and
- by a *guard* which meets the requirements of the Ontario Building Code where the change in level is greater than 600 mm (23 5/8 in.).



**Figure 4.1.4.1** Edge Protection

Where there is a change in direction along an *accessible route* and the intended destination of the route is not evident, directional signage shall be provided.

All portions of an *accessible route* shall be equipped to provide a minimum level of illumination of 50 lux (4.6 ft-candles). Exception: In outdoor park settings where routes are not normally illuminated, additional illumination is not required.

*Accessible routes*, paths or corridors having a slope steeper than 1:25 (4%) shall be designed as *ramps*, in compliance with 4.1.9. unless in exterior applications where the route shall be designed as a ramp when steeper than 1:20 (5%).

*Accessible routes* shall incorporate level rest areas spaced no more than 30 metres (98ft. – 5in.) apart.

All posts, pillars and/or columns, greater in height than 47", within an accessible route shall be clearly identified with a horizontal row of decals, or a continuous stripe, minimum 50 mm (2 in.) wide and of highly contrasting colour, mounted with its centre line between 1475 mm (58 in.) and 1525 mm (60 in.) from the floor or ground. Additionally, a second row of decals, or a continuous stripe, a minimum 50 mm (2 in.) wide and of highly contrasting colour shall be provided, mounted with its centreline between 1170 mm (46 in.) and 1220 mm (48 in.) above the floor or ground.

*Recreational trails* need flexibility in locations of rest areas (i.e. 30 to 90 m (98 ft. - 5 in. to 295 ft. - 3 in.) apart.)

Consultation with the Municipal Accessibility Advisory Committee, the public and persons with disabilities regarding the design and location of rest areas along exterior paths of travel must be undertaken as required by the AODA Accessibility Standard for the Design of Public Spaces.

Designated areas for snow piling to be provided at exterior *accessible routes*, located away from pedestrian routes.

All *facilities* shall have convex mirrors installed at hallway intersections along an *accessible route* to allow people who are deaf, deafened, or hard of hearing to see on-coming pedestrian traffic.

## **RELATED SECTIONS**

4.1.2 Ground and Floor Surfaces

4.1.7 Gates, Turnstiles and Openings

4.1.9 Ramps

4.1.10 Curb Ramps

4.2.3 Elevated Platforms

4.4.7 Signage

4.4.8 Detectable Warning Surfaces

4.4.12 Glare and Light Sources

4.4.13 Lighting

4.4.14 Materials and Finishes

4.4.15 Texture and Colour

## **4.1.5 ENTRANCES**

### **RATIONALE**

Design decisions concerning entrances will have an immediate impact on the independence and dignity of everyone entering a facility. Entrances that address the full range of individuals using the facility promote a spirit of inclusion that separate *accessible* entrances do not. Features such as canopies can limit the influence of weather conditions on this already busy area and also make an entrance more obvious to a person with a cognitive disability or someone unfamiliar with the facility.

### **APPLICATION**

All *entrances* used by staff and/ or the public shall be *accessible* and comply with this section. In a retrofit situation where it is *technically infeasible* to make all staff and public *entrances accessible*, at least 50% of all staff and public *entrances* shall be *accessible* and comply with this section.



## Exhibit A

*Accessible* public *entrances* must be provided in a number at least equivalent to the number of exits required by the Ontario Building Code. (This paragraph does not require an increase in the total number of public *entrances* required for a *facility*.)

An *accessible* public *entrance* must be provided to each tenancy in a *facility*.

In police stations and municipal courts subject to 4.5.8 and 4.5.9, public *entrances* that are secured shall be *accessible*, as required in 4.5.8 and 4.5.9.

If direct access is provided for pedestrians from an enclosed parking garage to a *facility*, at least one direct *entrance* from the parking garage to the *facility* must be *accessible*.

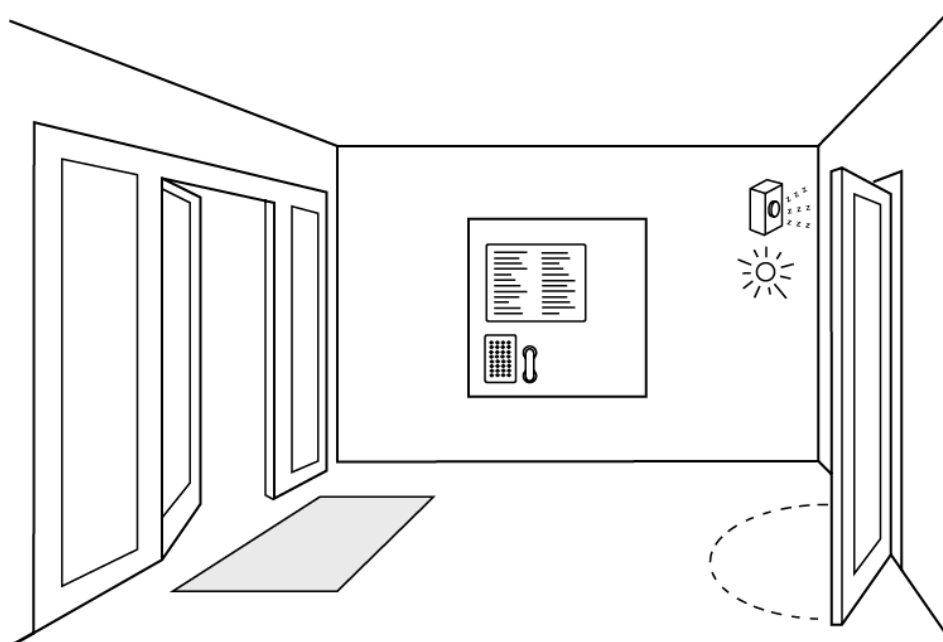
If access is provided for pedestrians from a pedestrian tunnel, walkway or pedestrian bridge, at least one entrance to the facility from each tunnel, walkway or bridge must be *accessible*.

If the only *entrance* to a *facility* or tenancy is a *service entrance*, that *entrance* shall be *accessible*.

*Entrances* which are not *accessible* shall have directional *signage* complying with 4.4.7 which indicates the nearest *accessible entrance*.

*Accessible entrances* shall be identified with *signage* incorporating the International Symbol of Access and complying with applicable provisions of 4.4.7.

Accessible entrances shall be served by an accessible route in compliance with 4.1.4.



**Figure 4.1.5.1** Entrance Vestibule

### RELATED SECTIONS

4.1.1 Space and Reach Requirements

4.1.6 Doors

4.1.7 Gates, Turnstiles and Openings

4.1.8 Windows, Glazed Screens and Sidelights

4.4.2 Controls and Operating Mechanisms

4.4.7 Signage

4.4.10 Information Systems

4.4.11 Card Access, Safety and Security Systems

4.4.13 Lighting

## 4.1.6 DOORS

### RATIONALE

Sufficiently wide doorways are advantageous to individuals using wheelchairs or scooters, pushing strollers, or making a delivery. However, a raised threshold at the base of the door could impede any one of these same individuals. This same group, with the addition of children, seniors or even someone carrying packages, would have difficulty opening a heavy door and would benefit from some form of automatic door opener. Where permitted and where feasible, entrances without doors are preferred.

Independent use of doors is desirable. Reliance on assistance from others to open doors is not an *accessible* or dignified solution.

Careful thought to the direction of the door swing can enhance the usability and limit the hazard to other pedestrians. Sliding doors can be easier for some individuals to operate, and can also require less wheelchair maneuvering *space*. Doors that require two hands to operate are not considered to be *accessible*. Revolving doors are not *accessible* for persons using wheelchairs and strollers. Also, the coordination required to use such doors may be difficult for children or a person with a cognitive disability.

Glazed doors can present a hazard to all individuals and especially those with a visual *impairment*. The inclusion of *colour contrast* strips across the glass, mounted at eye level, as well as *colour contrasting* door frames and door hardware, will increase the safety and visibility of a glazed door for a person with a visual *impairment*.

### APPLICATION

All doors used by staff or the public shall comply with this section.

In a retrofit situation where it is *technically infeasible* to make all doors *accessible*, at least one door at each *accessible space* shall comply with this section.

Exception: Doors not requiring full user passage, such as shallow closets, may have the *clear* opening reduced to 510 mm (20 in.) minimum.

Each door that is an *element* of an *accessible route* shall comply with this section.

Each door required by 4.4.1 (Emergency Exits, Fire Evacuation and Areas of Rescue Assistance) shall comply with this section.

Where a door system incorporates multiple door leaves at a single location, at least one of the door leaves shall comply with this section.

Power operators shall be provided at the following door locations:

- entrances required by 4.1.5;
- washrooms that include an *accessible* toilet stall;
- change rooms that contain *accessible* toilet and shower facilities, as well as a private *accessible* change room; and
- intermediate doorways across primary circulation routes within a *facility*. Exception: Doors that are held-open using electromagnetic hold-open devices.

Mats and mat sinkages at doors shall comply with this section.

Revolving doors or turnstiles shall not be the only means of passage at an *accessible entrance* or along an *accessible route*. An *accessible* gate or door shall be provided adjacent to the turnstile or revolving door and shall be designated to facilitate the same use pattern.

Frameless glass doors and/or sidelights shall not be used. Door hardware on all doors throughout a facility (not only those deemed *accessible*), shall comply with the door hardware requirements of this section.

## **DESIGN REQUIREMENTS**

Where permitted, rooms without doors are preferred.

*Accessible* doors shall be on an *accessible route* that complies with 4.1.4.

The minimum *clear* opening of doorways shall be 950 mm (37-1/2 in.), measured between the face of the door and the opposite door stop with the door open 90 degrees. In a retrofit situation where it is *technically infeasible* to provide this clearance, the minimum *clear* opening of doorways may be reduced to 850 mm (33 1/2 in.).

Doors shall have level wheelchair-maneuvering *space* on both sides of the door. Unless equipped with a power door operator, doors shall have a *clear space* beside the latch, as described in Table 4.1.6.

Exception: The *clear space* is not required on the inactive side of a door, where access is provided from one side only - such as to a closet.

**Table 4.1.6a Maneuvering Space: Front approach – Side-hinged door**

|                  | <b>Depth (in mm)</b> | <b>Width (in mm)</b>               | <b>Space beside latch (in mm)</b> |
|------------------|----------------------|------------------------------------|-----------------------------------|
| <b>Pull side</b> | 1525 (60 in.)        | 1600 (63 in.) (*1525 (60 in.))     | 600 (23-5/8 in.)                  |
| <b>Push side</b> | 1370 (54 in.)        | 1250 (49-1/4 in.) (*1220 (48 in.)) | 300 (11-3/4 in.)                  |

**Table 4.1.6b Maneuvering Space: Latch-side approach – Side-hinged door**

|                  | <b>Depth (in mm)</b>               | <b>Width (in mm)</b>           | <b>Space beside latch (in mm)</b> |
|------------------|------------------------------------|--------------------------------|-----------------------------------|
| <b>Pull side</b> | 1370 (54 in.) (*1220 (48 in.))     | 1600 (63 in.) (*1525 (60 in.)) | 600 (23-5/8 in.)                  |
| <b>Push side</b> | 1370 (54 in.) (*1100 (43-1/4 in.)) | 1525 (60 in.)                  | 600 (23-5/8 in.)                  |

**Table 4.1.6c Maneuvering Space: Hinge-side approach – Side-hinged door**

|                  | <b>Depth (in mm)</b>              | <b>Width (in mm)</b>           | <b>Space beside latch (in mm)</b> |
|------------------|-----------------------------------|--------------------------------|-----------------------------------|
| <b>Pull side</b> | 2440 (96 in.) (*1525 (60 in.))    | 2440 (96 in.) (*1525 (60 in.)) | 600 (23-5/8 in.)                  |
| <b>Push side</b> | 1370 (54 in.) (1100 (43-1/4 in.)) | 1830 (72 in.)                  | 450 (17-3/4 in.)                  |

**Table 4.1.6d Maneuvering Space: Sliding door**

|                  | <b>Depth (in mm)</b>               | <b>Width (in mm)</b> | <b>Space beside latch (in mm)</b> |
|------------------|------------------------------------|----------------------|-----------------------------------|
| <b>Pull side</b> | 1370 (54 in.)                      | 1550 (61 in.)        | 300 (11-3/4 in.)                  |
| <b>Push side</b> | 1370 (54 in.) (*1100 (43-1/4 in.)) | 2150 (84-5/8 in.)    | 600 (23-5/8 in.)                  |

In retrofit situations where it is *technically infeasible* to provide the required clearances at doors, the clearances may be reduced as shown by the asterisk (\*).

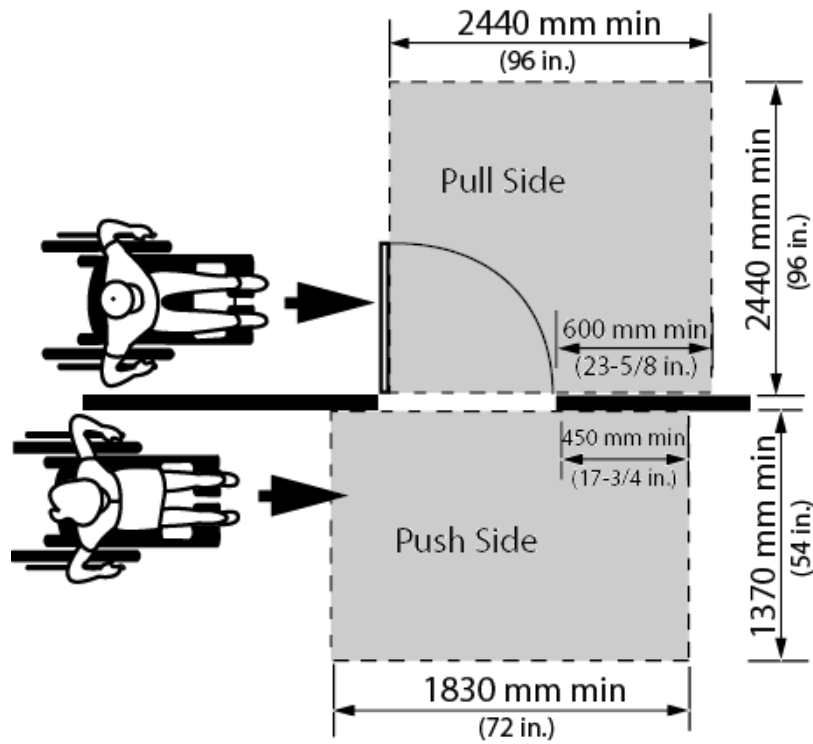


Figure 4.1.6.1 Hinge Side Approach at Hinged Doors

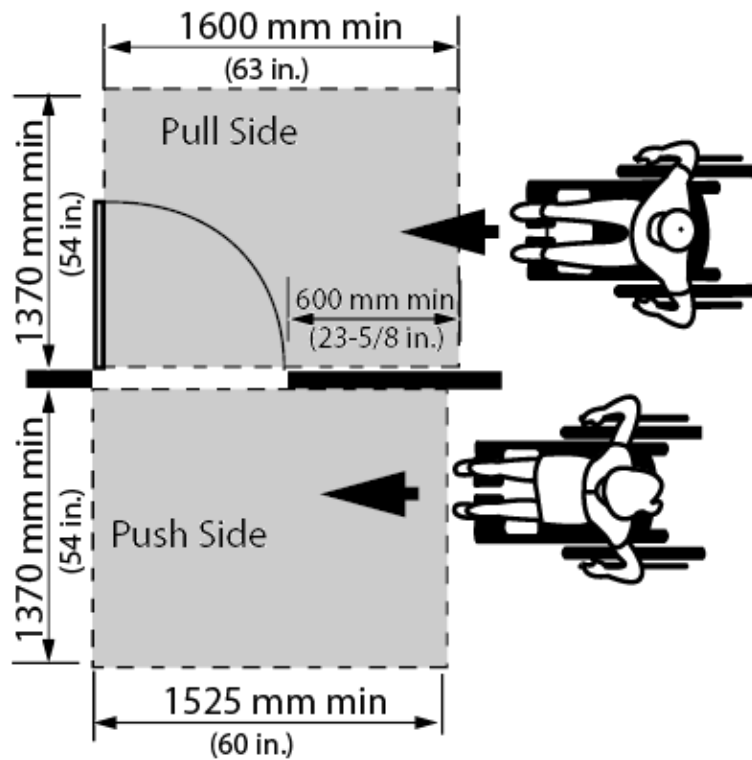


Figure 4.1.6.2 Latch Side Approach at Hinged Doors

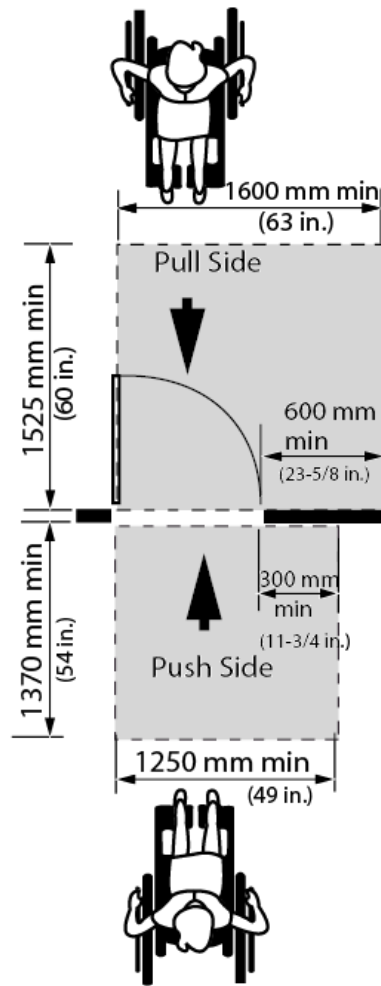
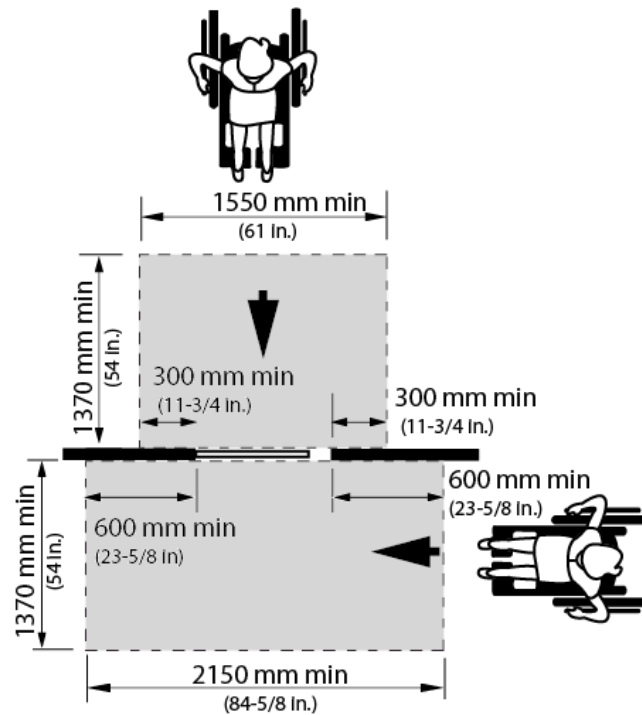


Figure 4.1.6.3 Front Approach at Hinged Doors



**Figure 4.1.6.4** Front and Side Approach at Sliding Doors

The required *clear space* beside the latch is to be unobstructed for the full height of the door.

Vestibules located in a barrier-free *path of travel* shall provide:

- where the doors into the vestibule are in series, a distance between the doors of at least 1525 mm (60 in.) plus the width of any door that swings into the space in the *path of travel* from one door to another; and
- where the doors into the vestibule are not aligned, a turning diameter of 1525 mm (60 in.) within the vestibule clear of any door swing. (See figure 4.1.6.6)

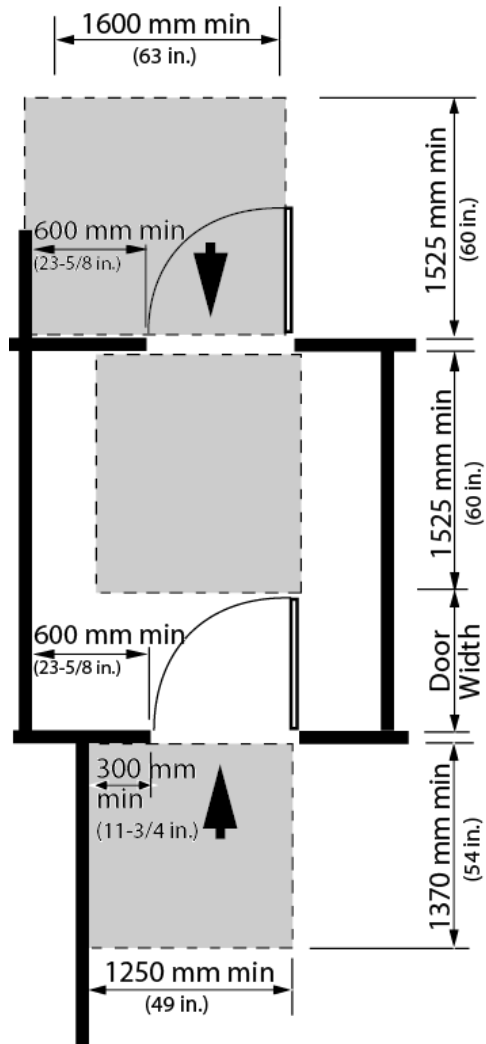
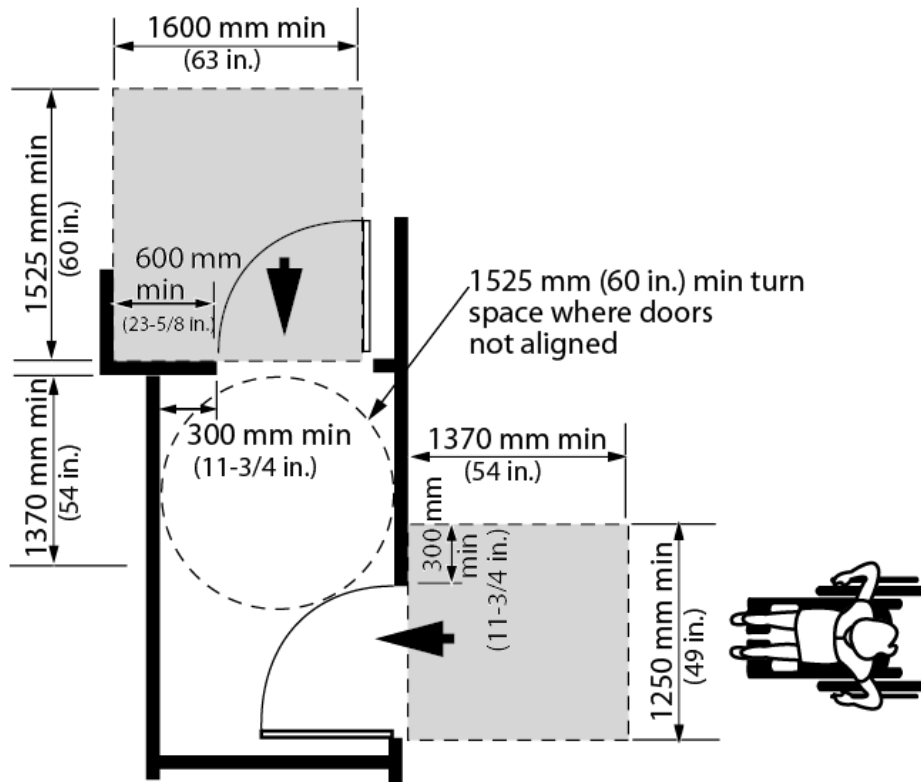


Figure 4.1.6.5 Maneuvering Space at Doors in Series





**Figure 4.1.6.6** Maneuvering Space at Doors in Series

Thresholds shall

- be not more than 13 mm (1/2 in.) high; and
- where over 6 mm (1/4 in.) high, be beveled at a maximum slope of 1:2.

Door hardware (operating devices such as handles, pulls, latches, and locks) shall

- be mounted between 900 mm (35-1/2 in.) and 1000 mm (39-3/8 in.) from the floor.

Operating hardware on sliding doors shall be exposed and usable from both sides when sliding doors are fully open.

The maximum door opening force for pushing or pulling open a door shall be

- 38 N (8.5 lb.) for exterior hinged doors;
- 22.2 N (4.6 lb.) for interior hinged doors; and
- 22.2 N (4.6 lb.) for sliding or folding doors.

Door closers shall be adjusted to the least pressure possible, but never more than the opening forces noted in this section.

The sweep period of door closers shall be adjusted so that, from an open position of 90 degrees, the door will take not less than 3 seconds to move to a semi-closed position of approximately 12 degrees.

Power-assisted swinging doors shall

- take not less than 3 seconds to move from the closed to the fully open position; and
- require a force of not more than 66 N (13.8 lb.) to stop door movement.

Permanent mats and metal gratings at *entrances* and in vestibules shall be sunk level with the floor, so as not to create a tripping hazard. Occasional mats (e.g. runners used in bad weather) should be level with the floor surface and/or have a gently beveled edge, so as not to create a tripping hazard.

Where power door operators are provided they shall

- be clearly visible;
- be located to allow a person using a wheelchair or scooter to stop immediately adjacent to the control (refer to 4.1.1) and in a location that is logical and does not require the user to go around the door or an obstacle after activated;
- be located at least 600 mm (23-5/8 in.) from any inside corner;
- be installed on the latch side so as to allow persons to activate the opening of the door from either side, and shall be located not less than 600 mm (23-5/8 in.) and not more than 1500 mm (59 in.) beyond the door swing where the door opens towards the control;
- have its centre located 1000 - 1100 mm (39-3/8 - 43-1/4 in.) from the floor;
- incorporate controls that are clearly visible and have a functional face dimension of not less than 150 mm (5-15/16 in.) in diameter where the control is circular, or 50 mm (2 in.) by 100 mm (3-15/16 in.) where the control is rectangular;
- incorporate the International Symbol of Access for Persons with Disabilities;
- where pressure-sensitive mats, overhead beams or proximity scanners are used to detect traffic, incorporate systems that will detect individuals using wheelchairs; and
- where exterior doors swing open into a pedestrian area, incorporate safety *guards* that comply with 4.1.3, projecting a minimum of 300 mm (11-3/4 in.) beyond both sides of the open door. (See Figure 4.1.6.8).

Where doors are not equipped with a closing device, the edge of door shall be *colour contrasted* to the face of the door. (See Figure 4.1.6.9).

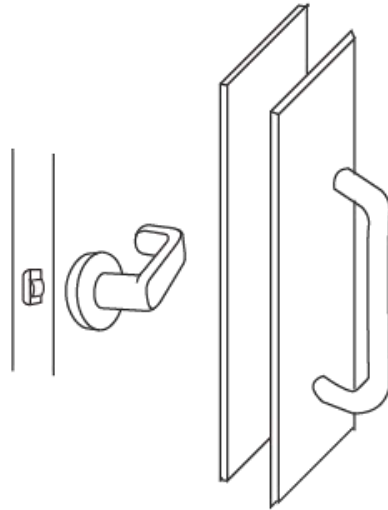
Doors and/or door frames shall incorporate pronounced *colour contrast*, to differentiate them from the surrounding environment. Door handles and other operating mechanisms shall incorporate pronounced *colour contrast*, to differentiate them from the door itself.

Where a door incorporates glazing or is fully glazed, it shall comply with Section 4.1.8 (Windows, Glazed Screens and Sidelights).

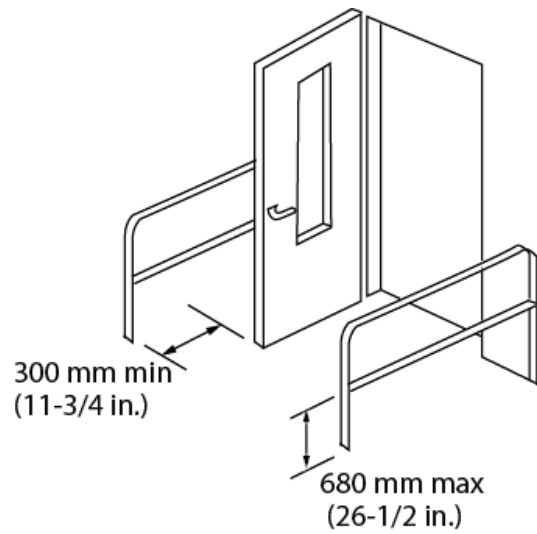
If doorways have two independently operated door leaves, at least one active leaf shall comply with minimum clear opening width requirements and maneuvering space at door requirements.

Exemption: For safety and security reasons related to patients that have dementia, Rideaucrest Home may need to install dual controls for power operated doors that must be operated

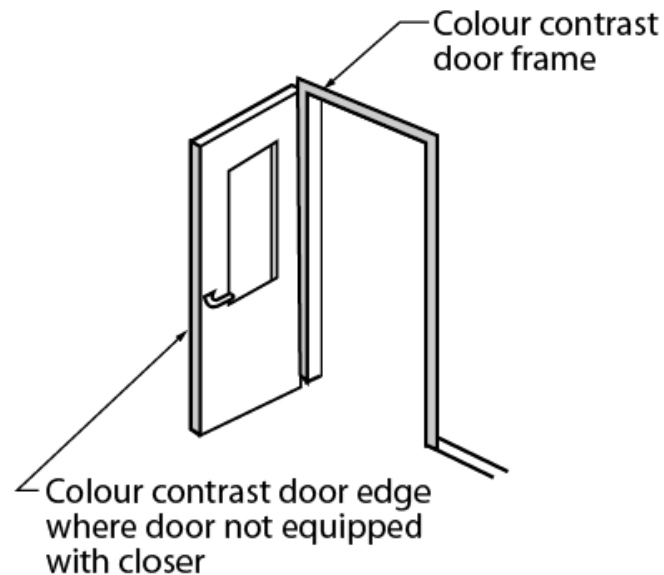
simultaneously, and are therefore exempt from the provision that each control must be a minimum of 150 mm (5-7/8 in.) in diameter.



**Figure 4.1.6.7** Examples of Accessible Hardware



**Figure 4.1.6.8** Detectable Safety Guards



**Figure 4.1.6.9** *Colour contrast at Doors*

## **RELATED SECTIONS**

- 4.1.1 Space and Reach Requirements
- 4.1.7 Gates, Turnstiles and Openings
- 4.1.8 Windows, Glazed Screens and Sidelights
- 4.4.2 Controls and Operating Mechanisms
- 4.4.7 Signage
- 4.4.10 Information Systems
- 4.4.11 Card Access, Safety and Security Systems

## **4.1.7 GATES, TURNSTILES AND OPENINGS**

### **RATIONALE**

Gates and turnstiles should address the full range of users that may pass through them. Single-bar gates designed to be at a convenient waist height for ambulatory persons are at neck and face height for children and chest height for persons who use wheelchairs or scooters.

Revolving turnstiles are a physical impossibility for a person in a wheelchair to negotiate. They are also difficult for persons using canes or crutches, or persons with poor balance. An adjacent opening of an *accessible* width is essential for wheelchair access, as well as access for those using other mobility devices, strollers, walkers or delivery carts.

**APPLICATION**

Gates, turnstiles and openings shall comply with this section.

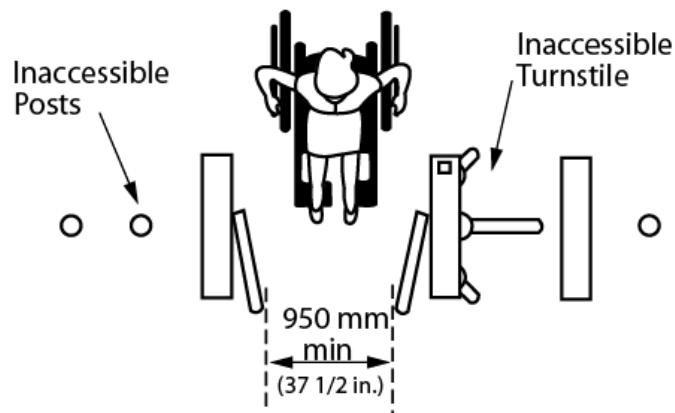
**DESIGN REQUIREMENTS**

Where gates or openings are provided through fences or screens to *public use* areas, such openings shall be *accessible* (i.e., a minimum of 950 mm (37-1/2 in.)) wide, to allow free passage for persons who use a wheelchair or scooter. (Note: Hardware should be suitable for autonomous use with a closed fist, and any closing device should not be spring-loaded).

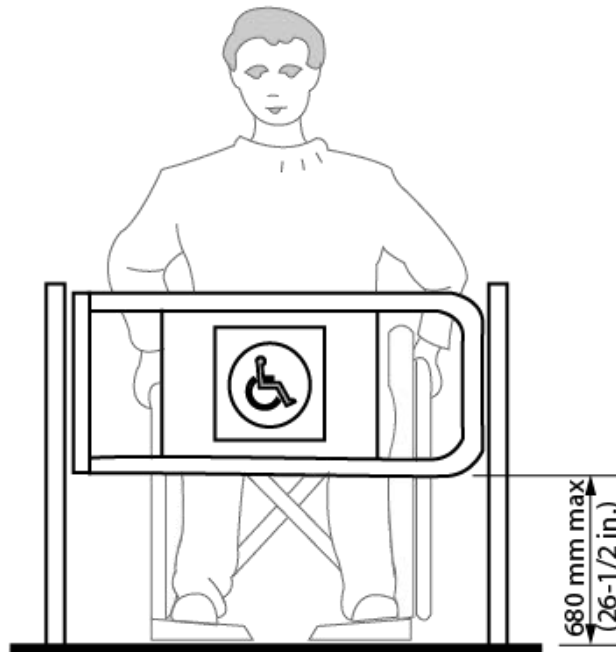
Where turnstiles or other ticketing control devices are utilized which are not *accessible*, a gate or opening which is *accessible* shall be provided in the same location and shall incorporate the International Symbol of Access for Persons with Disabilities.

Turnstiles shall incorporate a pronounced *colour contrast* to differentiate them from the surrounding environment.

Where gates are incorporated into a chain-link fencing system, the poles at either side of the gate shall incorporate a pronounced *colour contrast* from the fence and the surrounding environment.



**Figure 4.1.7.1** Access at Turnstile



**Figure 4.1.7.2** Access at Turnstile

## RELATED SECTIONS

- 4.1.1 Space and Reach Requirements
- 4.1.6 Doors
- 4.1.8 Windows, Glazed Screens and Sidelights
- 4.4.2 Controls and Operating Mechanisms
- 4.4.7 Signage
- 4.4.10 Information Systems
- 4.4.11 Card Access, Safety and Security Systems

## 4.1.8 WINDOWS, GLAZED SCREENS & SIDELIGHTS

### RATIONALE

Broad expanses of glazing in screens, sidelights and doors can be difficult to detect. While this may be a particular concern to persons with a *visual impairment*, it is possible for anyone to walk into a clear sheet of glazing especially if they are distracted or in a hurry.

Persons who use wheelchairs or scooters experience the *facility* from a seated position thereby lowering their eye level and reach range. This necessitates the need for lower sill heights and easily reached operating mechanisms. Window controls and operating devices should also respect the limitations of hand strength or dexterity encountered with different types of *disabilities*, including arthritis.

## APPLICATION

Windows, glazed screens, fully-glazed sidelights, fully-glazed doors and vision panels in doors shall comply with this section

Frameless glass doors and/or sidelights shall not be used.

## DESIGN REQUIREMENTS

Fully-glazed doors and sidelights at exterior *entrances* or vestibules, as well as fully-glazed interior doors, screens and sidelights shall be marked with a continuous opaque strip that is colour and brightness contrasted to the background of the door;

- is at least 50 mm (2 in.) wide;
- is located across the width of the door at a height of 1350 to 1500 mm (53-1/8 to 59 in.) above the finished floor; and
- may incorporate a logo or symbol provided such logo or symbol does not diminish
  - the opacity of the strip;
  - the width of the strip;
  - the colour and brightness contrast of the strip to the background of the door; and
  - the continuity of the strip across the width of the door.

Optionally, a second row of decals, or a continuous strip, a minimum 50 mm (2 in.) wide and of highly contrasting colour to the background shall be provided, mounted with its centreline between 1170 mm (46 in.) and 1220 mm (48 in.) above the floor or ground.

Where decals are used, they shall be located at a maximum of 150 mm (5-7/8 in.) from centre to centre. The decals can either be 50 mm (2 in.) square or round, and/ or of a special design (e.g., a logo) provided the solid portion of the decals provides high *colour contrast* and is easy to identify by persons who are visually impaired.

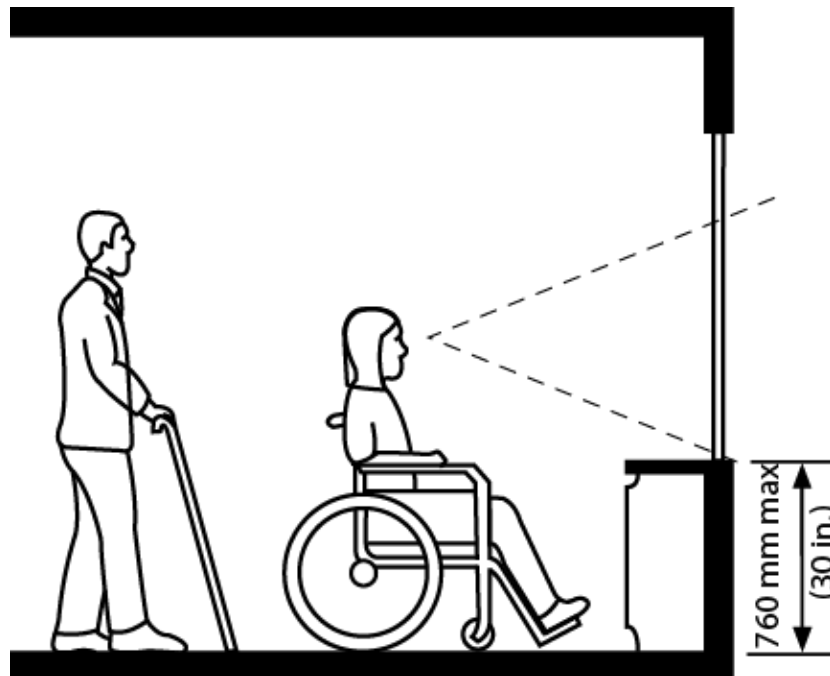
Where etched or patterned glass is used, decals or a stripe of highly *contrasting* colour shall still be provided.

Where frameless glass panels are used, exposed edges shall be identified with a vertical safety stripe, applied to cap the ends of each exposed glass panel.

Where viewing windows or vision panels are provided,

- the sill height shall be no more than 760 mm (30 in.) from the floor;
- where horizontal transoms are incorporated, the transoms shall not be located between 1060 mm (42 in.) and 1220 (48 in.) from the floor; and
- where a vision panel is provided in a door in a barrier-free *path of travel*, such panel shall be at least 75 mm (2-15/16 in.) in width and be located so that, the bottom of the panel is not more

than 900 mm (35-7/16 in.) above the finished floor, and the edge of the panel closest to the latch is not more than 250 mm (9-13/16 in.) from the latch side of the door.



**Figure 4.1.8.1 Window Sill Height**

In facilities with operable windows, window opening hardware shall

- be mounted between 400 mm (15-3/4 in.) and 1200 mm (47 in.) from the floor;
- be operable using one hand; and
- not require fine finger control, tight grasping, pinching, or twisting of the wrist to operate.

## **RELATED SECTIONS**

4.1.1 Space and Reach Requirements

4.4.2 Controls and Operating Mechanisms

## **4.1.9 RAMPS**

### **RATIONALE**

Traditionally, *ramps* have been synonymous with wheelchair accessibility. However, *ramps* can be problematic in providing accessibility. *Ramps* can be difficult and dangerous to negotiate. Also, the physical *space* required for ramps makes them cumbersome to integrate into a *facility*. However, where a change in level already exists or cannot be avoided, a properly designed *ramp* can provide access for those using wheelchairs or scooters, pushing strollers or moving packages on a trolley.

The design of the *ramp* is critical to its usefulness and safety. A steeply inclined *ramp* is difficult to ascend when using a wheelchair, and can increase the risk of the wheelchair tipping backwards. Descending a steep *ramp* can also be hazardous. Any cross slope will further increase the effort



required to negotiate the *ramp*. Maneuvering space at the top and bottom are also important factors in a *ramp*'s usability. Level areas at points along a long *ramp* enable an individual to rest.

Textured surfaces, edge protection and *handrails* all provide important safety features. Heated surfaces are recommended to address the safety concerns associated with snow and ice.

## **APPLICATION**

Any part of an interior *accessible route* with a running or cross slope steeper than 1:25 (4%) shall be considered a *ramp* and shall comply with this section. Any part of an exterior *accessible route* with a running or cross slope steeper than 1:20 (5%) shall be considered a *ramp* and shall comply with this section.

## **DESIGN REQUIREMENTS**

*Accessible ramps* shall be on an *accessible route* complying with 4.1.4.

Where an accessible ramp is located in a barrier-free *path of travel* serving a building entrance, signage incorporating the International Symbol of Access and in compliance with 4.4.7 shall be installed to indicate the location of the accessible ramp and the accessible entrance.

The *running slope* shall be between 1:25 (4%) and 1:15 (6.67%) for interior applications. For interior applications, in a retrofit situation, where it is *technically infeasible* to provide a *ramp* with a *running slope* between 1:25 (4%) and 1:15 (6.67%), a *running slope* not steeper than 1:12 (8.3%) may be used. Shallower slopes are preferred. The *running slope* shall be between 1:20 (5%) and 1:15 (6.67%) for exterior applications.

The maximum *cross slope* of *ramp* surfaces shall be 1:50 (2%).

The ramp must not have any openings in the surface that allow the passage of an object that has a diameter of more than 13 mm (1/2 in.).

*Ramps* shall have level landings at the top and bottom of each run and also where the *ramp* changes direction.

A *colour contrasting* strip 50 mm (2 in.) in width shall be located at the top and bottom of the running slope of any *ramp*.

The maximum horizontal length between landings shall not exceed 9 m (29'-6").

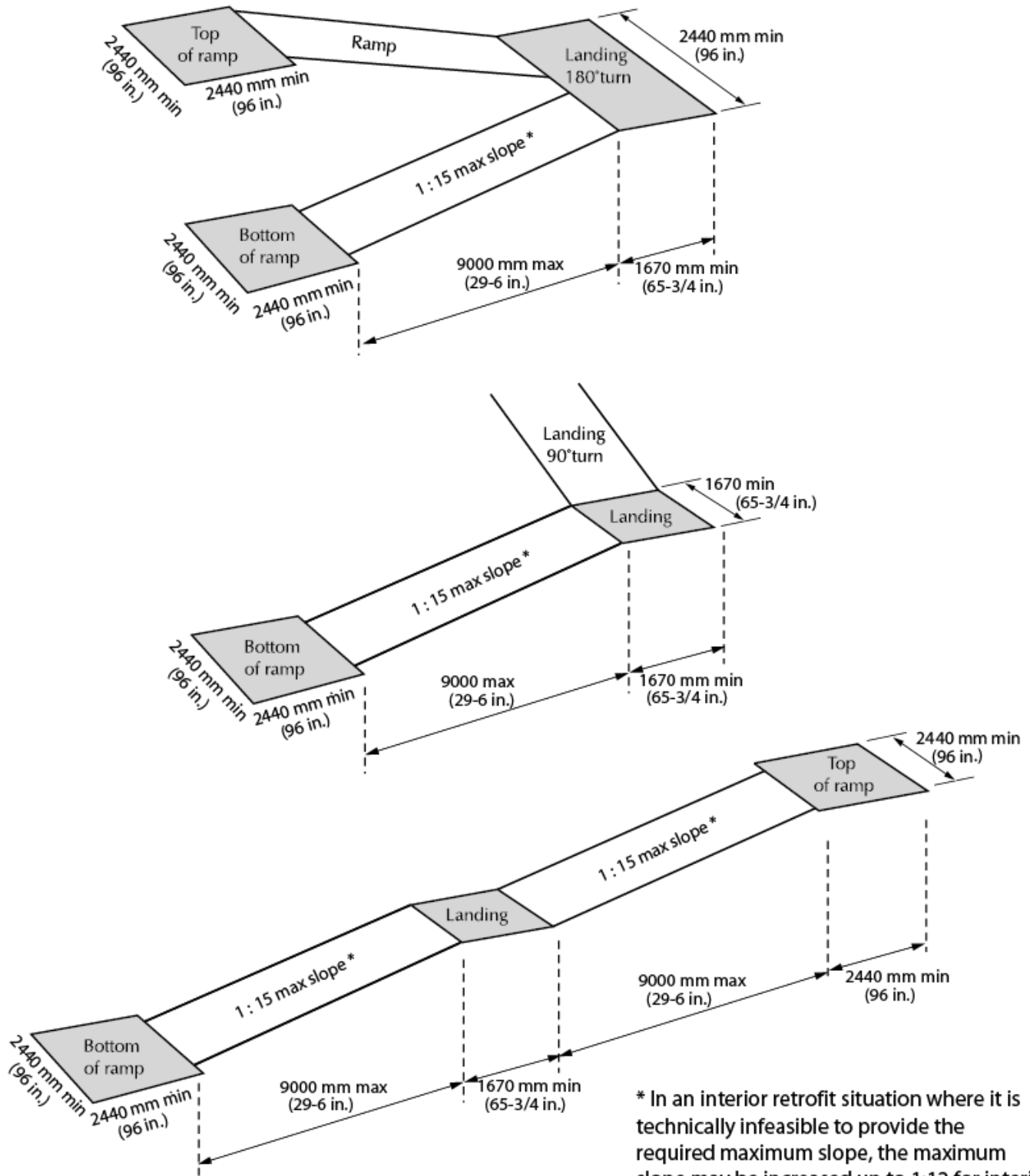
Landings shall

- be at least as wide as the widest *ramp* run leading to it;
- have a minimum size not less than 2440 x 2440 mm (96 x 96 in.) if located at the top or bottom of a *ramp* or if served by a doorway so that the level area extends at least 600 mm (24 in.) beyond the latch side of the door opening, except that where the door opens away from the ramp, the area extending beyond the latch side of the door opening may be reduced to 300

## Exhibit A

mm (11-13/16 in.). (In a retrofit situation where creating a suitably sized landing is *technically infeasible*, the required landing size may be reduced to 1670 x 1670 mm (65-3/4 x 65-3/4 in.);

- where an intermediate landing at the switchback of a U-shaped *ramp* (Refer to Figure 4.1.9.1), have a length not less than 1670 mm (65-3/4 in.) and a width not less than 2440 mm (96 in.). In a retrofit situation where creating a suitably sized landing is *technically infeasible*, the required landing width may be reduced to 2120 mm (84 in.);
- where an intermediate landing at the corner of an L-shaped *ramp* (Refer to Figure 4.1.9.1), have a length and width not less than 1670 mm (65-3/4 in.); and
- where an intermediate landing at a straight *ramp* (Refer to Figure 4.1.9.1), have a length not less than 1670 mm (65-3/4 in.) and at least the same width of the ramp.



\* In an interior retrofit situation where it is technically infeasible to provide the required maximum slope, the maximum slope may be increased up to 1:12 for interior ramps. Exterior ramps cannot be steeper than 1:15.

### Figure 4.1.9.1 Minimum Ramp Landing Dimensions

Ramp and landing surfaces shall be firm, stable, and slip-resistant.

At slope transitions, ramps shall have a 40 - 60 mm (1-5/8 - 2-3/8 in.) wide *colour contrasted* strip across the width of the ramp, located on the sloped surface.

Outdoor ramps and their approaches shall be designed so that water will not accumulate on walking surfaces.

Edges of ramps and landings shall be protected with a wall or *guard* on both sides.

Where a *guard* is provided, it shall

- comply with the requirements of the Ontario Building Code;
- have a minimum height of 1070 mm (42-1/8 in.) measured vertically from the ramp surface to the top of the *guard*; and
- be designed so that no member located 140 - 900 mm (5-1/2 - 35-1/2 in.) above the ramp will facilitate climbing.

A ramp shall have handrails, which

- are on both sides;
- comply with 4.1.12;
- are continuous on the inside of switchback (U-shaped) or L-shaped ramps;
- extend horizontally at least 300 mm (11-3/4 in.) beyond the top and bottom of the ramp and return to the wall, floor, or post;
- measure between 865 mm (34 in.) and 920 mm (36 in.) from the ramp surface to the top of the handrail;
- have a width between handrails of 950 – 1650 (37 1/2 – 65 in.); and
- terminate at a wall, floor, post or other manner in a way that will not obstruct pedestrian travel or create a hazard.

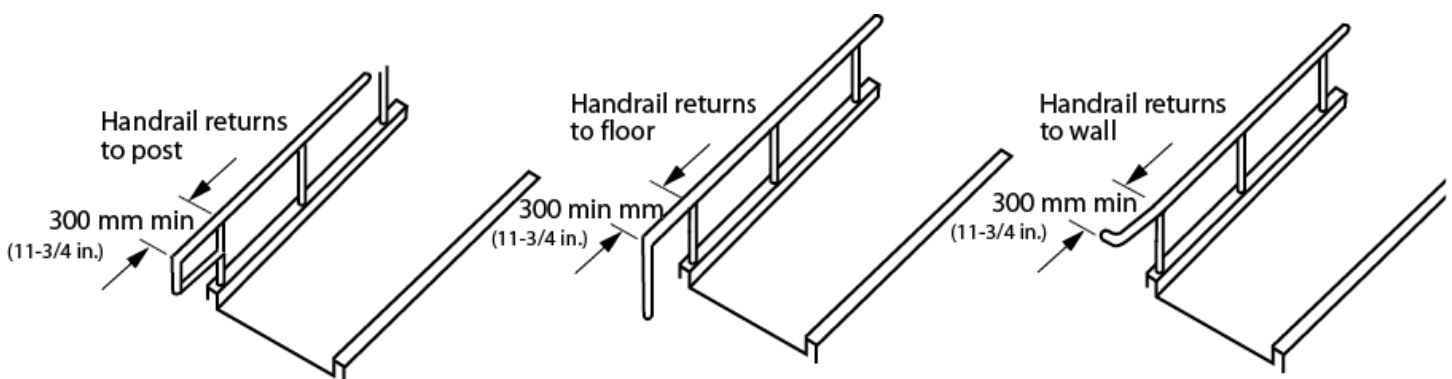
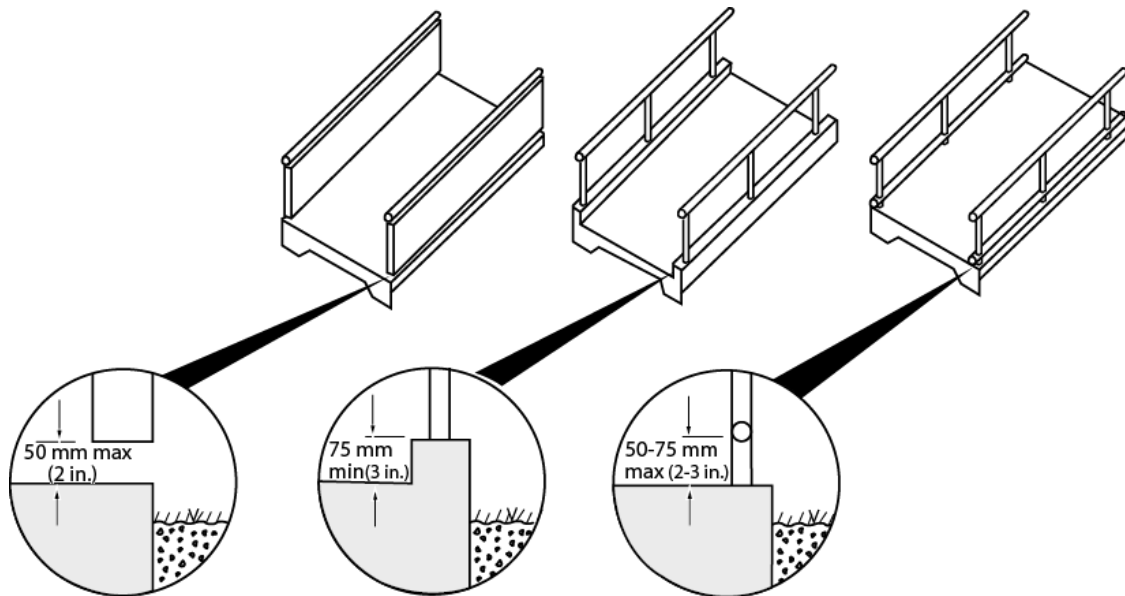


Figure 4.1.9.3 Horizontal Handrail Extensions



**Figure 4.1.9.4** Edge Protection at Ramps

**EXCEPTION:** Where a ramp serves as an aisleway for fixed seating, the requirement for ramp handrails does not apply. And Designated areas for snow piling to be provided at exterior ramps, located away from pedestrian routes.

## **RELATED SECTIONS**

4.1.1 Space and Reach Requirements

4.1.2 Ground and Floor Surfaces

4.1.6 Doors

4.1.10 Curb Ramps

4.1.12 Handrails

4.4.7 Signage

4.4.8 Detectable Warning Surfaces

4.4.12 Glare and Light Sources

4.4.13 Lighting

4.4.14 Materials and Finishes

4.4.15 Texture and Colour

## 4.1.10 CURB RAMPS

### RATIONALE

In the interest of moving people safely and efficiently off a roadway, the design of curb ramps is very important. The same issues related to the slopes of ramps apply equally to slopes of curb ramps. A well-designed curb ramp can be spoiled by an uneven or gapped transition between the road surface and curb ramp. Flared sides on the curb ramp eliminate the hazard of pedestrians stepping off of an edge. While a smooth transition and minimal slope are ideal for someone in a wheelchair, they are a potential hazard to an individual with a visual impairment who may not notice the transition from sidewalk to street. Textured surfaces become an important safety feature in this scenario.

Accessible paths of travel will be kept clear of all obstructions.

Snow accumulation at curb ramps should be removed completely after each snow fall.

### APPLICATION

*Curb ramps* complying with this section shall be provided wherever any *path of travel* crosses a curb.

### DESIGN REQUIREMENTS

*Accessible curb ramps* shall be on an *accessible route* complying with 4.1.4.

Accessible curb ramps shall align with the pedestrian route across the vehicle roadway.

The transition from the curb ramp to the road surface shall be smooth and flush.

The *running slope* shall be between 1:50 and 1:20 (2% - 5%).

The minimum width of *curb ramps*, exclusive of any flared sides, shall be 1200 mm (47-1/4 in.).

The maximum cross slope of the curb ramp must be no more than 1:50 (2%)

*Curb ramp* configuration shall be as illustrated in Figures 4.1.10.1 to 4.1.10.4.

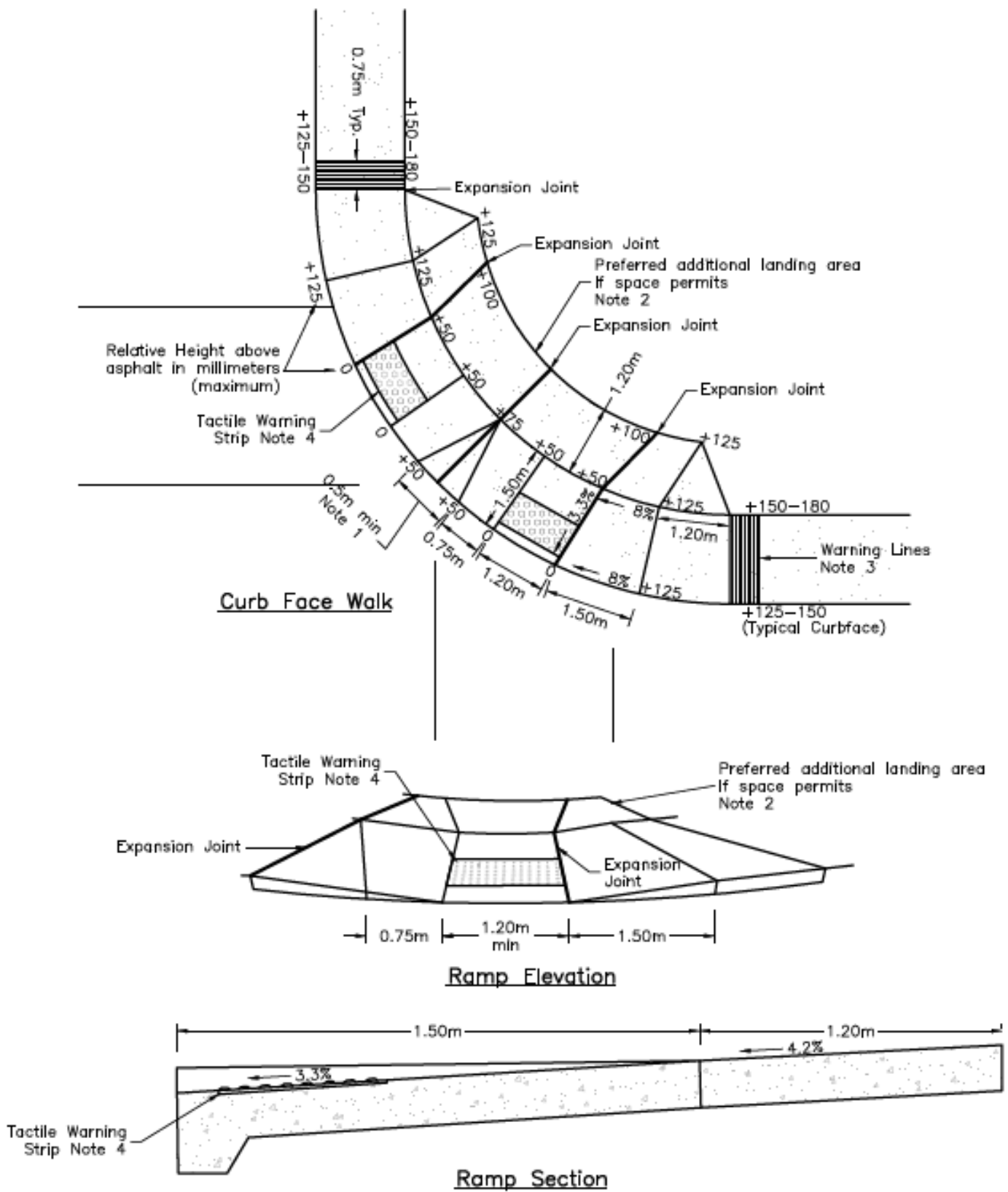


Figure 4.1.10.1 Concrete Sidewalk Ramps at Intersections – Curb Face Walk

## **Exhibit A**

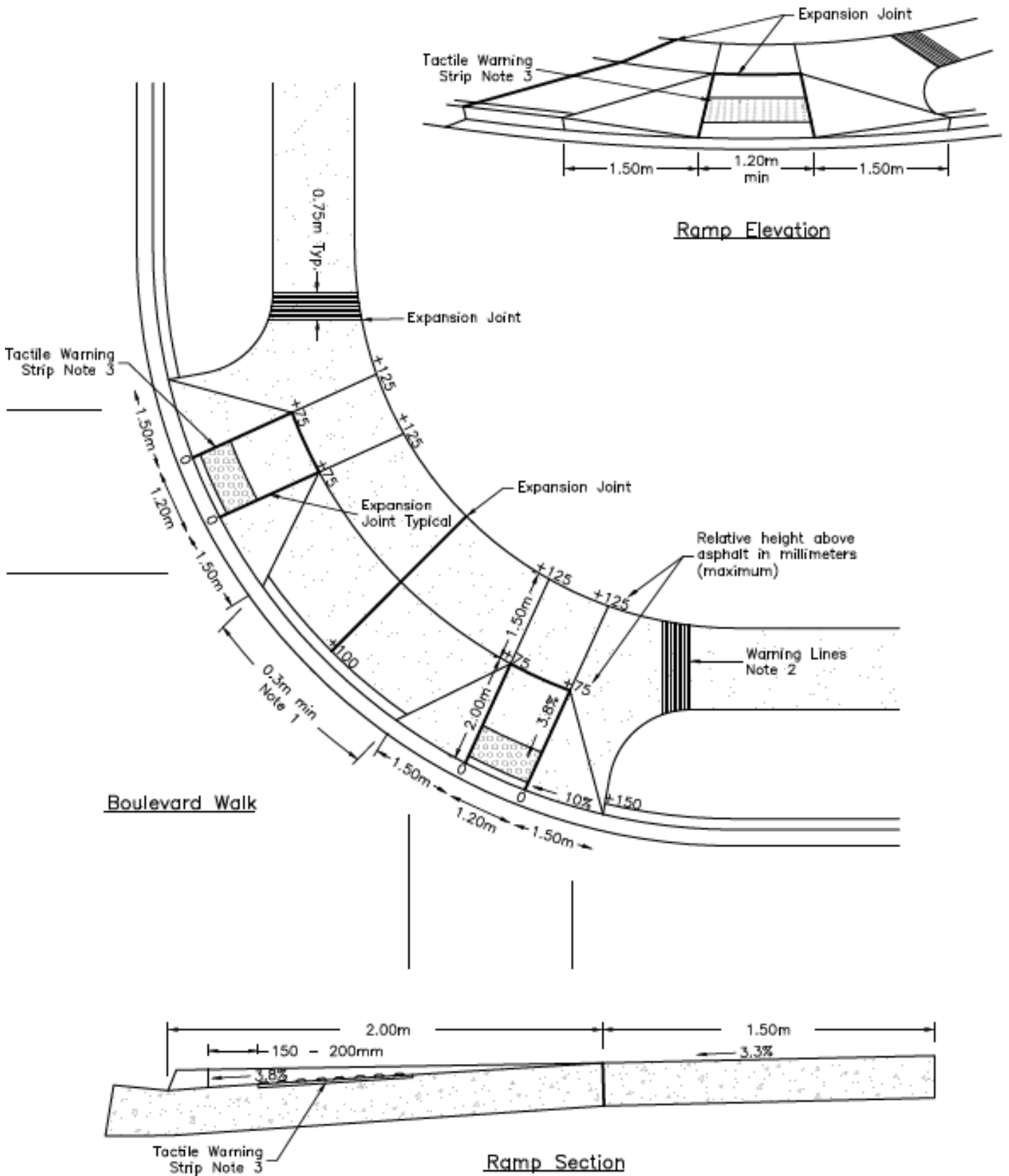
Minimum gap between ramp sections is 500 mm (19-3/4 in.). If width is not available, full depression will be maintained between ramps.

Preferred additional landing area to be constructed if right-of-way width is available and normal grading standards can be followed. Addition of barrier curb at rear of landing area is permissible to manage grading.

Warning lines shall be 10 mm (3/8-in.) by 10 mm (3/8-in.) made by a grooving tool with 50 mm (2-in.) spacing.



**Exhibit A**

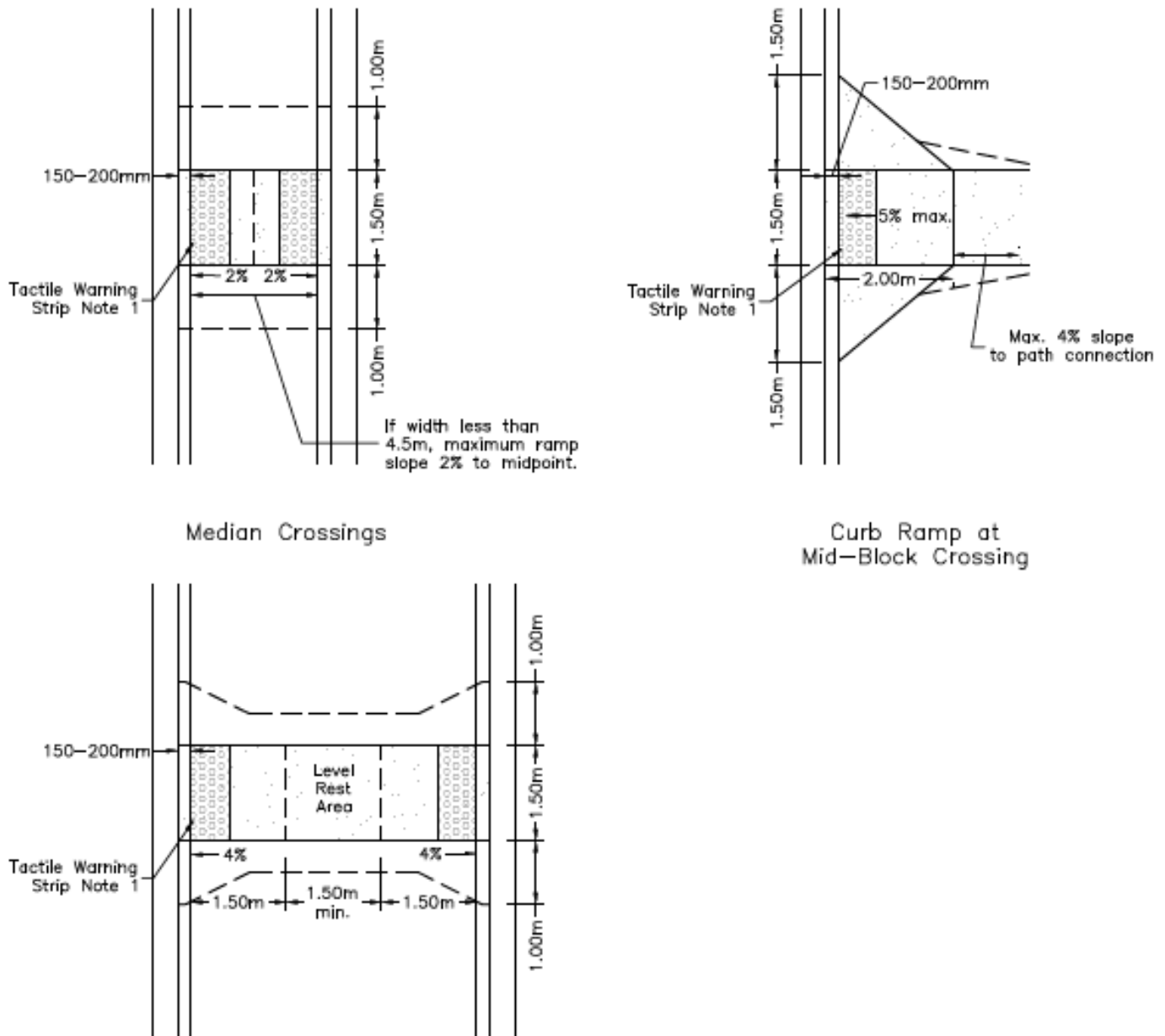


**Figure 4.1.10.2 Concrete Sidewalk Ramps at Intersections – Boulevard Walk**

## Exhibit A

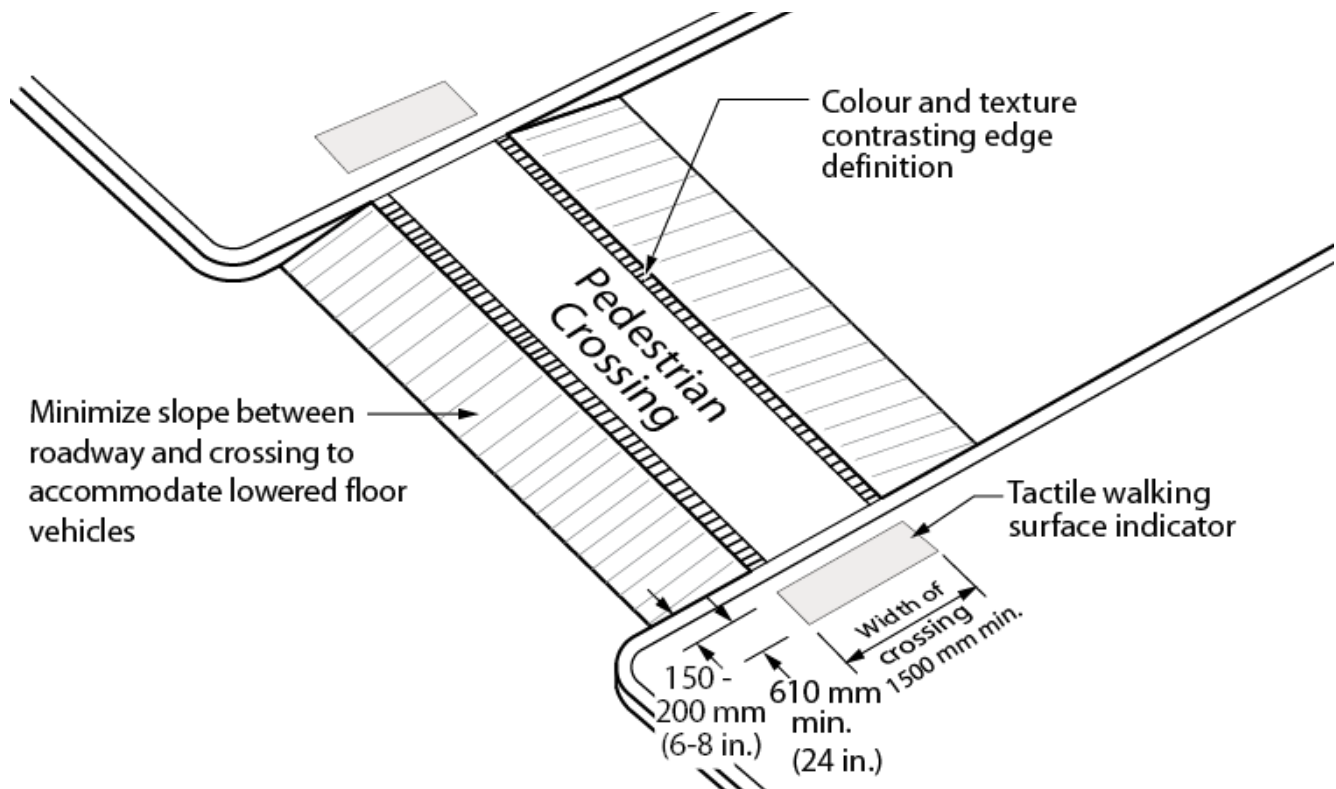
Minimum gap between ramp sections is 300 mm (11-13/16 in.). If width is not available, full depression will be maintained between ramps.

Warning lines shall be 10 mm (3/8-in.) by 10 mm (3/8-in.) made by a grooving tool with 50 mm (2-in.) spacing.



**Figure 4.1.10.3** Concrete Sidewalk Ramps at Mid-Block Crossings

If pedestrian movement is permitted along median, connection to curb cut ramp to be at maximum of 1:20 (5%) grade.



**Figure 4.1.10.4** Raised Pedestrian Crossing (Refer also to Ontario Provincial Standards for Roads & Public Works)

The maximum cross fall of gutters and road surfaces immediately adjacent to *curb ramps* shall be 1:20 (5%).

*Curb ramps* at pedestrian crosswalks shall be wholly contained within the area designated for pedestrian use.

Surfaces of *curb ramps* shall

- be slip-resistant; and
- incorporate a truncated dome *detectable warning* surface:
  - in compliance with 4.4.8;
  - be located at the bottom portion of the curb ramp;
  - 610 mm (23-5/8 in.) long, starting 150-200 (5-7/8 to 7-7/8 in.) from the back of the curb or 300 mm (11-13/16 in.) from the curb face;
  - extending the entire width of the ramp; and
  - have a smooth transition from the ramp and adjacent surfaces.

Provide dedicated area for snow piling from all curb ramps, away from pedestrian routes.

*Depressed Curbs:* Where a *depressed curb* is provided on an exterior *path of travel*, it shall

- have a maximum running slope of 1:20 (5%);
- be aligned with the direction of travel; and
- where provided at a pedestrian crossing, it shall incorporate a flat-topped domes or cones detectable warning surface that
  - complies with section 4.4.8;
  - is located at the bottom portion of the *depressed curb* that is flush with the roadway;
  - is set back 150 - 200 mm (5-7/8 - 7-7/8 in.) from the back of the curb or 300 mm (11-13/16 in.) from the curb face; and
  - is a minimum of 610 mm (24 in.) in depth.

## **RELATED SECTIONS**

4.1.1 Space and Reach Requirements

4.1.2 Ground and Floor Surfaces

4.4.8 Detectable Warning Surfaces

4.4.12 Glare and Light Sources

4.4.14 Materials and Finishes

4.4.15 Texture and Colour

## **4.1.11 STAIRS**

### **RATIONALE**

Stairs that are comfortable for many adults may be challenging for children, seniors or persons of short stature. Poorly designed nosings can present tripping hazards, particularly to persons with prosthetic devices or those using canes. Cues to warn a person with a *visual impairment* of an upcoming set of stairs are vitally important. These persons will also benefit from stairs designed with *contrasting* edges on treads. The appropriate application of *handrails* will aid all users and especially those that have difficulty ascending stairs.

### **APPLICATION**

Interior and exterior stairs shall comply with this section. In a retrofit situation

- stairs need not comply if they connect levels that are
- *accessible* by an elevator, *ramp* or other *accessible* means of vertical access; and
- dimensional changes to steps and landings are not required however all other design requirements must be met.

### **DESIGN REQUIREMENTS**

A flight of stairs shall

- have uniform riser heights (rise) and uniform tread depths (run);

## Exhibit A

- have a rise not more than 180 mm (7-16 in.) and not less than 125 mm (4-7/8 in.) high;
- have a run not more than 355 mm (14 in.) and not less than 280 mm (11 in.) deep, measured from riser to riser;
- incorporate detectable warning surfaces in compliance with 4.4.8.; and
- have no open risers

Nosings shall

- project not more than 25 mm (1 in.);
- have no abrupt undersides;
- have a curved or beveled leading tread edge of between 6 mm (1/4 in.) and 10 mm (3/8 in.);
- where projecting, be sloped to the riser at an angle not less than 60 degrees to the horizontal;
- be illuminated to a level of at least 100 lux (9.2 ft-candles);
- be slip-resistant; and
- have high tonal *contrast* markings that:
  - extend across the leading edge of the tread;
  - extend the full tread width of the leading edge of each step;
  - are 40 – 60 mm deep (1-5/8 - 2-3/8 in.); and
  - extend to the front edge of the nosing.

A detectable warning surface in compliance with 4.4.8 shall

- be installed at the top of the stairs, starting one tread depth back from the edge of the top stair;
- be installed at the leading edge of landings where a doorway opens onto stairs, starting one tread depth back from the edge of the landing; and
- extend the full tread width to a minimum depth of 610 mm (24 in.) commencing one tread depth from the edge of the stair.

Handrails for stairs shall:

- comply with 4.1.12;
- be installed on both sides;
- be of uniform height, ranging between 865 mm (34 in.) and 965 mm (38 in.) above the stair nosing;
- have a continuous inside handrail on switchback stairs;
- extend at the bottom of the stairs for a distance of one tread depth beyond the first riser, then horizontally not less than 300 mm (11-3/4 in.), at a height ranging between 865 mm (34-1/16 in.) and 920 mm (36 in.) above the floor;
- extend horizontally at the top of the stairs not less than 300 mm (11-3/4 in.), at a height ranging between 865 mm (34 in.) and 965 mm (36 in.) above the floor; and
- return to the wall, or post in a manner that will not obstruct pedestrian travel or create a hazard.

Stairs and landings forming part of a stair shall be protected by a wall or *guard* on both sides.

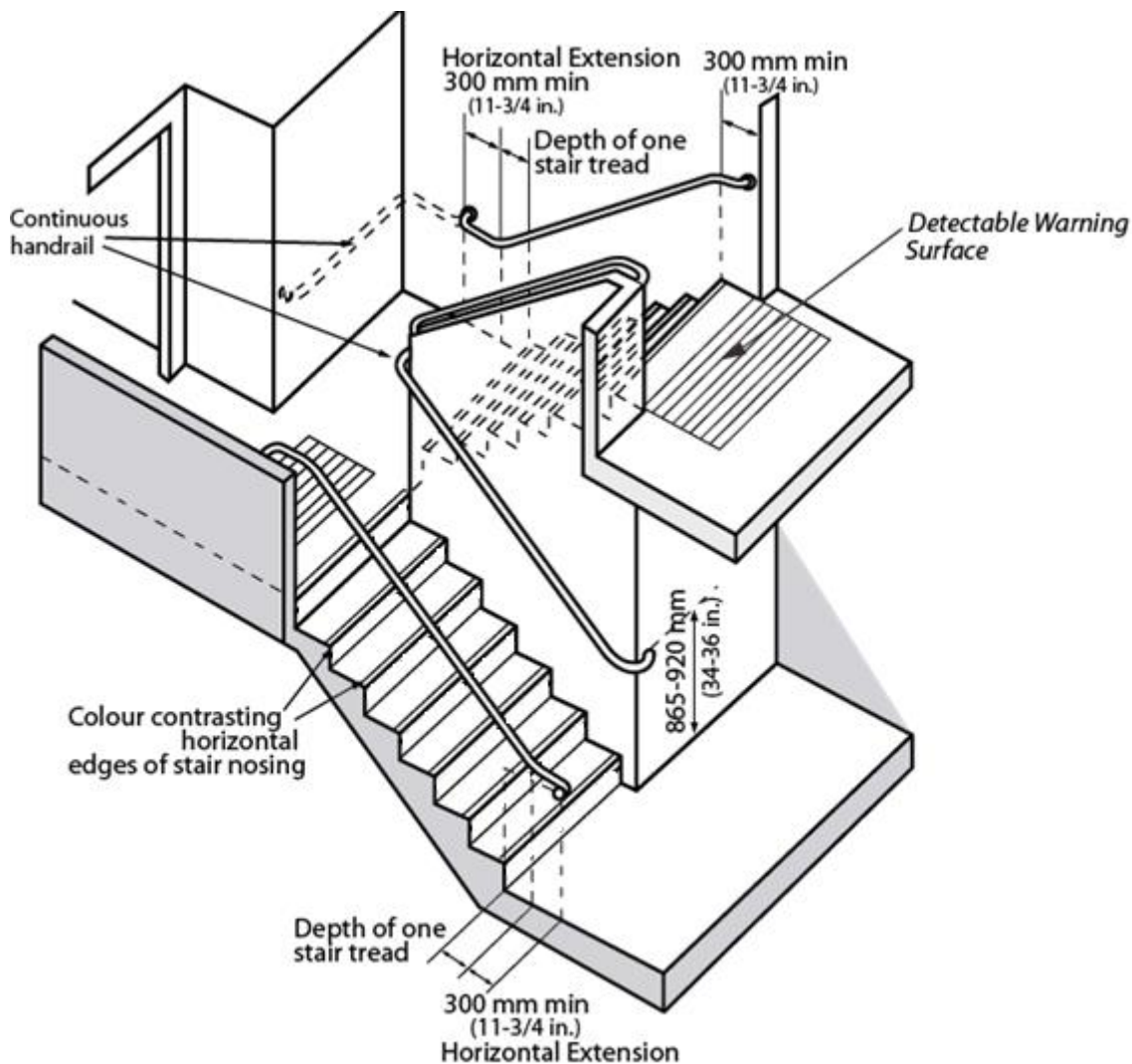
Where a *guard* is provided, it shall:

- comply with the requirements of the Ontario Building Code;
- have a minimum height of 920 mm (36 in.) measured vertically to the top of the *guard* from a line drawn through the outside edge of stair nosings; and
- have a minimum height of 1070 mm (42-1/8 in.) around landings.

Where stairs are greater than 2200 mm (86-5/8 in.) wide, one or more intermediate handrails which are continuous between landings must be provided and located so that they are no more than 1650 mm (65 in.) apart and there is 900 mm (35-1/2 in.) between at least one set of handrails.

Designated areas for snow piling to be provided at exterior stairs, located away from pedestrian routes.

Convex mirrors shall be placed at each stair landing to allow people who are deaf, deafened, or hard of hearing to see on-coming pedestrian traffic.



**Figure 4.1.11.1** Stair Design Criteria

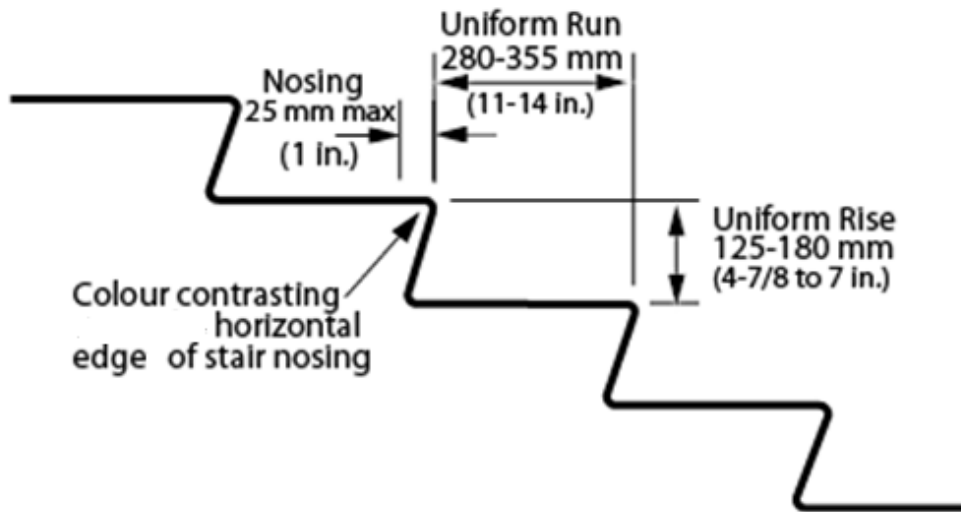


Figure 4.1.11.2 Stair Tread Criteria

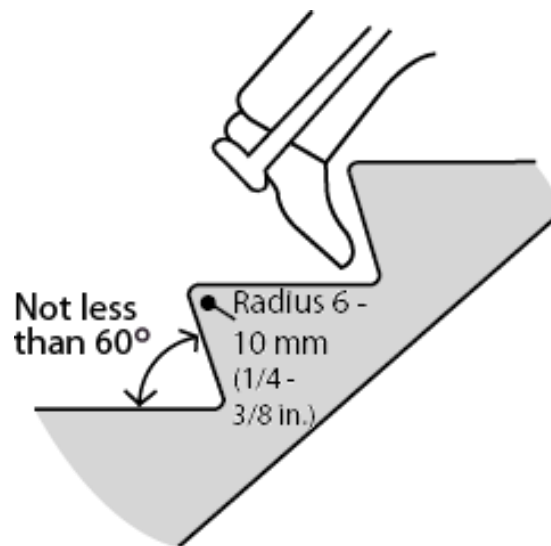


Figure 4.1.11.3 Raked Riser

**RELATED SECTIONS**

- 4.1.1 Space and Reach Requirements
- 4.1.2 Ground and Floor Surfaces
- 4.1.6 Doors
- 4.1.12 Handrails
- 4.4.7 Signage
- 4.4.8 Detectable Warning Surfaces

#### 4.4.12 Glare and Light Sources

#### 4.4.13 Lighting

#### 4.4.14 Materials and Finishes

#### 4.4.15 Texture and Colour

### 4.1.12 HANDRAILS

#### RATIONALE

In the design of *handrails*, consideration must be given to the range of hands that will grasp them. A *handrail* profile should be graspable for an adult hand as well as a child or a person with arthritis. The same is true for the heights of *handrails*.

Extensions of the *handrails* at the top and bottom of stairs, along with the use of a *contrasting* colour, provide important cues for a person with a visual *impairment*, and provide a support to ensure a safe and stable gait before ascending or descending the stairs. A continuous *handrail* with no interruptions ensures that a handhold will not be broken.

The *clear space* between the wall and *handrail* is also essential, as it must provide a *clear* area for the hand and knuckles but must not offer enough space into which an arm may slip during a fall or stumble on the stairs.

#### APPLICATION

Handrails shall comply with this section.

#### DESIGN REQUIREMENTS

Handrails shall

- be mounted 865 - 920 mm (34 - 36 in.) high, measured vertically from a line drawn through the outer edges of the stair nosings or from the surface of a ramp;
- be continuously graspable along their entire length and have a circular section of 30-40 mm (1-3/16 in. – 1-9/16 in.) in diameter, or any non-circular shape with a graspable portion that has a perimeter not less than 100 mm (3-15/16 in.) and not more than 125 mm (4-15/16 in.) whose largest cross-sectional dimension is not more than 45 mm (1-3/4 in.);
- be free of any sharp or abrasive *elements*;
- have continuous gripping surfaces, without interruption by newel posts, other construction *elements*, or obstructions that can break a handhold;
- have a *clear space* between the *handrail* and the wall or *guard* of at least 50 mm (2 in.), or at least 60 mm (2-3/8 in.) where the wall has a rough surface;
- extend parallel to the floor or ground surface a minimum distance of 300 mm (11-3/4 in.) beyond the beginning or end of a stair or ramp section; and
- terminate to a wall, floor, post or other manner that will not obstruct pedestrian travel or create a hazard.



## Exhibit A

A recess containing a *handrail* shall extend at least 450 mm (17-3/4 in.) above the top of the rail.

Handrails and their supports shall be designed and constructed to withstand the loading values obtained from the non-concurring application of

- a concentrated load of not less than 0.9 kN (200 lb.) applied at any point and in any direction; and
- a uniform load of not less than 0.7 kN/m (47 lb./ft.) applied in any direction to the *handrail*.

Handrails shall incorporate a pronounced *colour contrast*, to differentiate them from the surrounding environment.

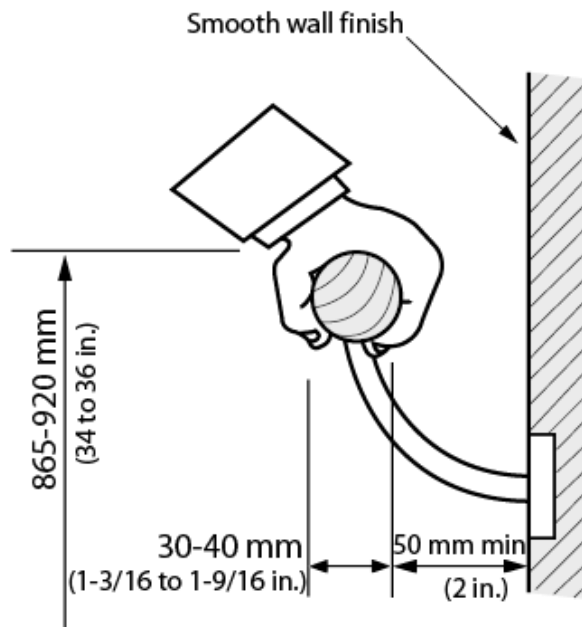


Figure 4.1.12.1 Handrail

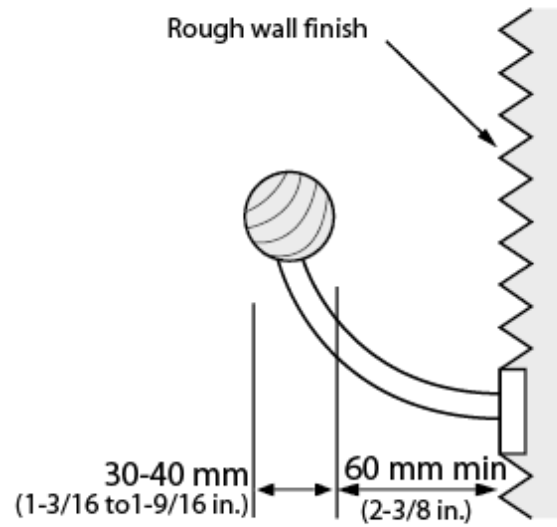


Figure 4.1.12.2 Handrail at Rough Wall

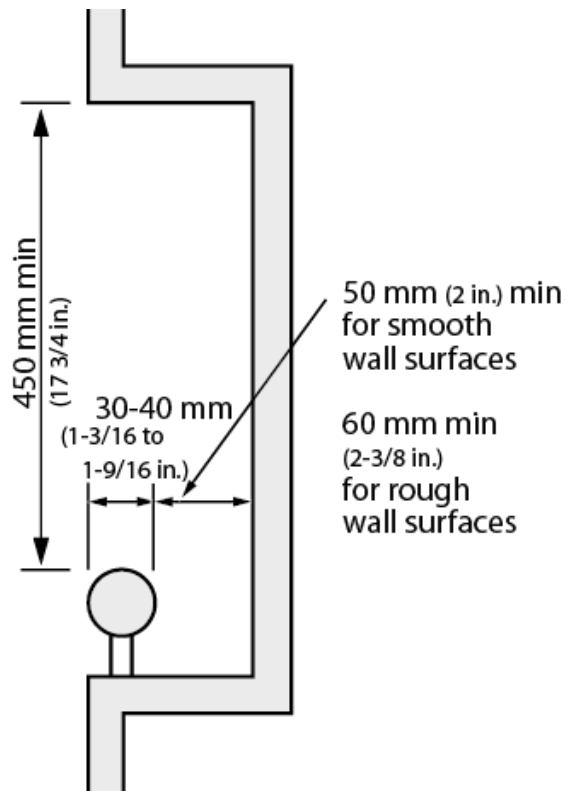


Figure 4.1.12.3 Handrail in Recess

**RELATED SECTIONS**

4.1.1 Space and Reach Requirements

4.1.9 Ramps

4.1.11 Stairs

4.4.15 Texture and Colour

**4.1.13 ESCALATORS****RATIONALE**

Boarding and stepping off of an escalator can be challenging for many persons who could have difficulty with the timing or agility. In addition, any lack of contrast on the edge of steps makes it difficult to determine the position of the steps or judge their speed. *Detectable warning surfaces* extending in front of the escalator provide warning to any pedestrian, especially someone with a visual *impairment*. *Contrasting* colour strips on stair edges are also necessary.

**APPLICATION**

Escalators shall comply with this section.

Where escalators are provided, an alternate *accessible route* shall also be provided in the same vicinity as the escalator.

In a building in which an escalator or inclined moving walkway provides access to any floor level above or below the entrance floor level, an interior barrier-free *path of travel* shall be provided to that floor level.

The route from the escalator or inclined moving walkway to the barrier-free *path of travel* shall be clearly indicated by appropriate signs.

In a building in which a moving walkway provides access between areas on the same floor level, a barrier-free *path of travel* shall be provided between the areas served by the walkway.

**DESIGN REQUIREMENTS**

Escalator installations shall include high definition (*colour contrast*) of tread edges and nosing. *Detectable warning surfaces* in compliance with 4.4.8 shall be provided at the head and foot of the escalator. The surface of escalator treads shall be in a matte finish, to minimize reflected glare.

Lighting over escalators shall be a minimum of 200 lux (18.4 ft.-candles), evenly distributed, from a low-glare light source.

**RELATED SECTIONS**

4.1.1 Space and Reach Requirements

4.1.2 Ground and Floor Surfaces

4.4.7 Signage

#### 4.4.8 Detectable Warning Surfaces

#### 4.4.12 Glare and Light Sources

#### 4.4.13 Lighting

#### 4.4.14 Materials and Finishes

#### 4.4.15 Texture and Colour

### 4.1.14 ELEVATORS

#### RATIONALE

The buttons used on elevators need to address a range of functional issues, including reach, dexterity and visual *impairments*, as discussed in 4.4.2 and 4.4.15. More specific to elevators is the need to provide audible cues for individuals with a visual *impairment* to identify different floor levels, as well as the direction of travel. These are, in fact, of benefit to anyone who uses the elevator. Adequate door-closing delays provide individuals using mobility devices additional time to reach, enter or exit the elevator car. The installation of a mirror can assist individuals using mobility devices to back out of an elevator where there is not sufficient space to turn around.

#### APPLICATION

One passenger elevator complying with this section shall serve each level, including *mezzanines*, in all multi-storey *facilities*, unless exempted below. If more than one elevator is provided, each passenger elevator shall comply with this section.

Freight elevators shall not be required to meet the requirements of this section, unless the only elevators provided are used as combination passenger and freight elevators for use by the public and freight elevators for use by the public and employees.

Elevator access is not required:

- in elevator pits, elevator penthouses, mechanical rooms, piping or equipment catwalks;
- when *accessible ramps* in compliance with 4.1.9 are used in lieu of an elevator;
- to levels of fire halls and ambulance stations not served by grade-level entry, which do not contain *public use* facilities; and
- when platform lifts (wheelchair lifts) in compliance with 4.1.15 and applicable Provincial Codes are used in lieu of an elevator, only under the following conditions:
  - to provide an *accessible route* to a performing area in an assembly occupancy;
  - to comply with wheelchair viewing position line-of-sight and dispersion requirements of 4.3.2;
  - to provide access to raised judges' benches, clerks' stations, speakers' platforms, jury boxes and witness stands or to depressed areas, such as the well of a court; and

- to provide access to incidental occupied *spaces* and rooms that are not open to the general public and which house no more than five persons, including, but not limited to, equipment control rooms and projection booths.

**DESIGN REQUIREMENTS**

*Accessible* elevators shall be on an *accessible route* in compliance with 4.1.4.

*Accessible* elevators shall be identified by *signage* in compliance with applicable provisions of 4.4.7.

Elevators shall be automatic and be provided with a two-way automatic-leveling device to maintain the floor level to  $\pm 13$  mm (1/2 in.).

Power-operated horizontally sliding car and landing doors opened and closed by automatic means shall be provided.

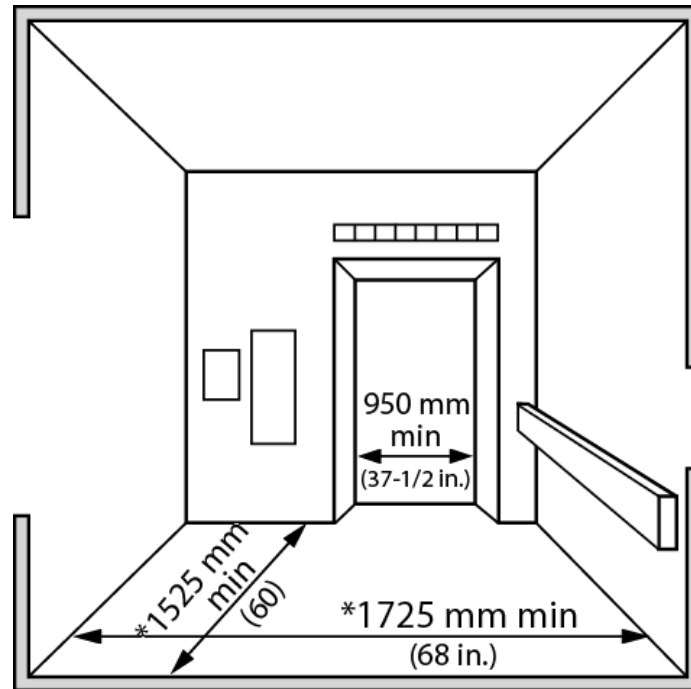
The *clear* width for elevator doors shall be minimum 950 mm (37-1/2 in.). In a retrofit situation where it is *technically infeasible* to provide a *clear* width of 950 mm (37-1/2 in.), the *clear* elevator door width may be reduced to 900 mm (35-1/2 in.). In high-use public facilities, the door clear opening width should be not less than 1065 mm (42 in.).

Doors shall be provided with a door re-opening device that will function to stop and reopen the car door and an adjacent hoist way door to minimum 950 mm (37-1/2 in.), in the event the car door is obstructed while closing. This re-opening device shall also be capable of sensing an object or person in the path of a closing door at a nominal  $125 \pm 25$  mm ( $5 \pm 1$  in.) and  $735 \pm 25$  mm ( $29 \pm 1$  in.) above the floor without requiring contact for activation.

Elevator doors should remain fully open for minimum 8 seconds. This time may be reduced by operation of the door-close button.

The minimum distance between the walls or between wall and door, excluding return panels, shall not be less than 1725 x 1525 mm (68 in. x 60 in.). In facilities with high public use, such as arenas, libraries or entertainment complexes, the distance between walls or between wall and door shall be 2030 x 1525 mm (80 in. x 60 in.).

Exception: In a retrofit situation where it is *technically infeasible* to install an appropriately sized elevator, a LU/ LA (Limited Use/Limited Application) elevating device with a platform length of at least 1525 mm (60 in.), may be used.



**Figure 4.1.14.1** Elevator Cab.

\* In high-use public facilities, increase minimum dimensions to 2030 x 1525 mm (80 x 60 in.) with a clear door opening width of at least 1065 mm (42 in.)

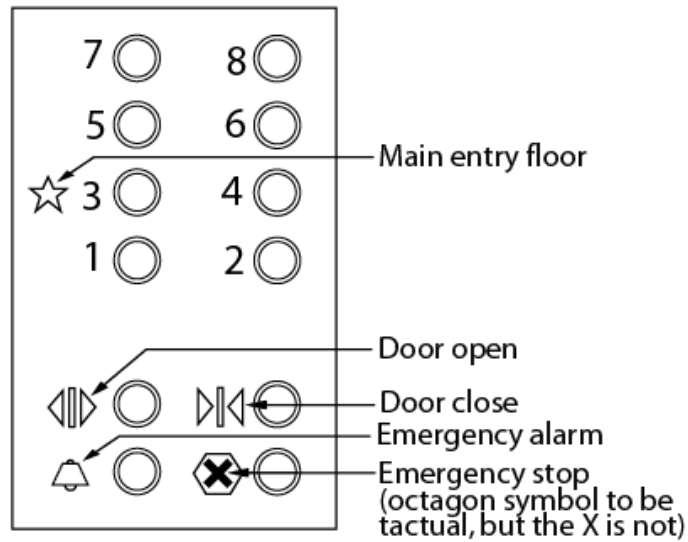
Car controls shall be readily *accessible* from a wheelchair upon entering an elevator.

Floor register buttons in elevator cabs shall:

- be a minimum 19 mm (3/4 in.) in size and may be raised, flush or recessed. The depth of flush or recessed buttons when they are being operated shall not exceed 10 mm (3/8 in.); and
- be provided with visual and momentary audible indicators to show when each call is registered. The visual indicators shall be extinguished when each call is answered.

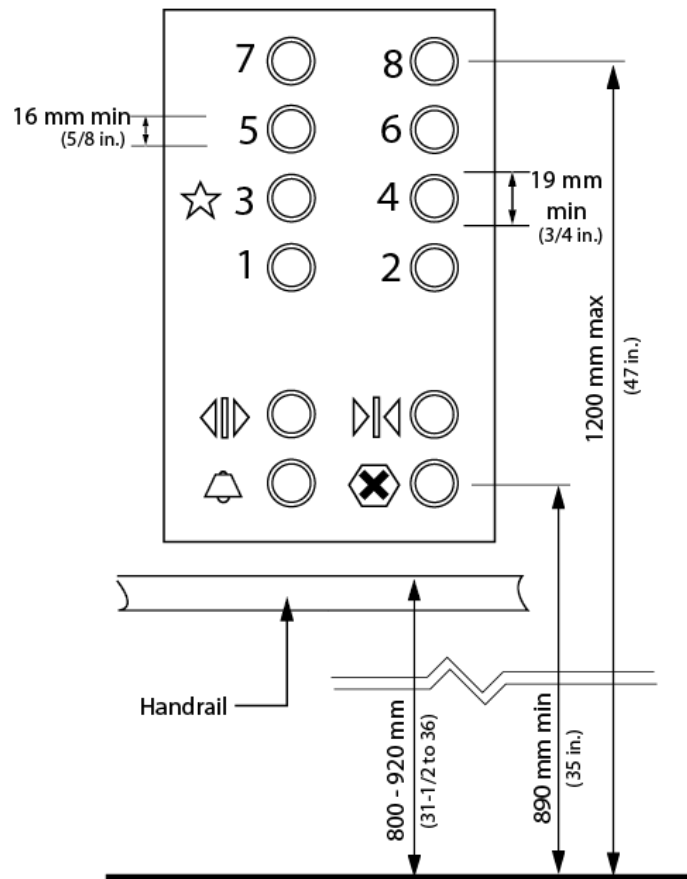
All car control buttons shall be designated by Grade 2 Braille characters and by raised standard alphabet characters for letters, Arabic characters for numbers, and standard symbols. Markings shall be a minimum of 16 mm (5/8 in.) high and raised a minimum of 0.75 mm (1/32 in.), placed immediately to the left of the buttons to which they apply.

Exception: Where the call buttons are mechanical, the raised markings may be on the buttons.



**Figure 4.1.14.4** Tactile Symbols

Emergency car controls and door-operating buttons shall be grouped together at the bottom of the control panel. The centre line of the alarm button and the emergency stop switch shall be not less than 890 mm (35 in.) above the floor. The centre line of the highest floor button shall be no higher than 1200 mm (47 in.) above the floor. Other controls may be located where it is convenient.



**Figure 4.1.14.2** Control Panel

An indicator shall be provided in the car to show the position of the car in the hoist way, by illuminating the indicator corresponding to the landing at which the car is stopped or passing. Indication characters shall be on a *contrasting colour* background and a minimum of 16 mm (5/8 in.) high.

Floors of elevator cabs shall have a firm and slip-resistant surface that permits easy movement of wheelchairs or scooters.

Handrails shall be provided on all non-access walls at a height of 800 to 920 mm (31-1/2 to 36 in.) with a *space* of 40 to 45 mm (1-9/16 to 1-3/4 in.) between the rails and wall.

The illumination at the car controls and landing sill shall be not less than 100 lux (10 ft-candles).

The centre line of hall call buttons shall be  $920 \pm 25$  mm ( $36 \pm 1$  in.) above the floor. Buttons shall be a minimum of 20 mm (13/16 in.) in size, mounted one above the other.

Hall visual indication shall be provided to show each call that is registered and that is extinguished when the call is answered.



## Exhibit A

Hall or in-car lanterns shall be provided. The centre line of the fixture shall be a minimum of 1830 mm (72 in.) above the floor. An audible signal shall be provided when the elevator stops at the landing. Visual *elements* shall be a minimum of 60 mm (2-3/8 in.) in the smallest direction.

All elevator hoist way *entrances* shall have raised Arabic numerals and Braille floor designations provided on both jambs. The characters shall be a minimum of 50 mm high (2 in.) and at least 0.75 mm (1/32 in.) and shall be placed on both sides of the door jambs, with the centreline at  $1500 \pm 25$  mm ( $59 \pm 1$  in.) from the floor.

As the car stops at a floor, the floor and direction of travel shall be announced using voice-annunciation technology.

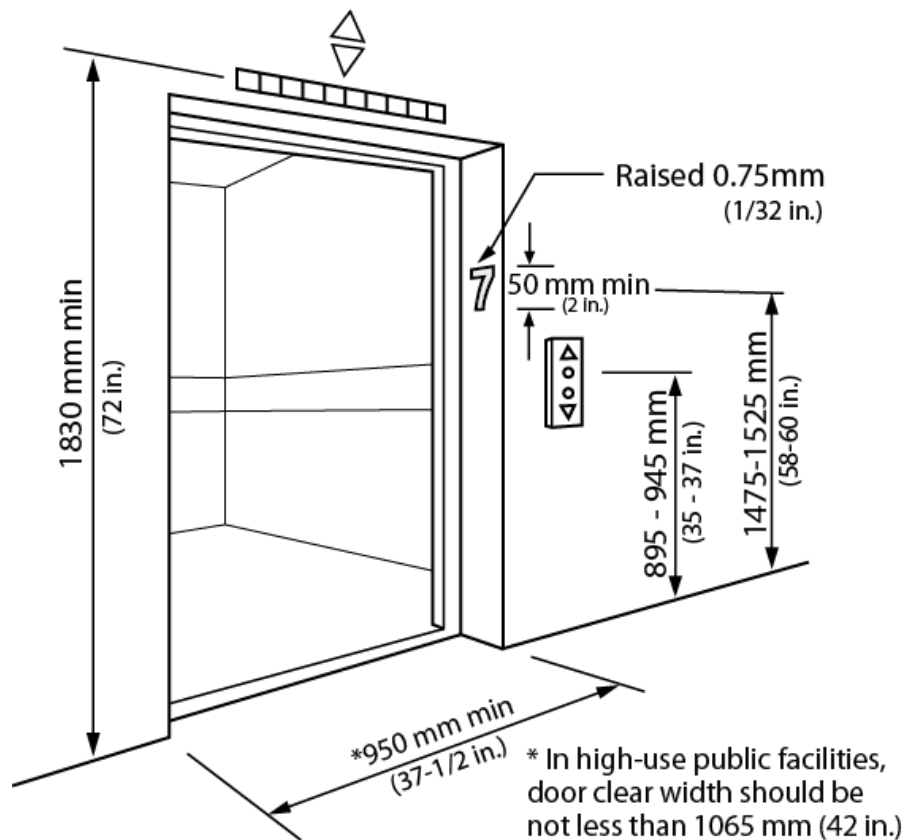


Figure 4.1.14.3 Elevator Entry

Elevators shall be linked by an emergency call system to a monitored location within the *facility* with two-way communication ability. The highest *operable portion* of the 2-way communication system shall be a maximum of 1200 mm (47 in.) above the floor of the car. It shall be identified by a raised symbol and lettering located adjacent to the device. The symbol shall be a minimum of 38 mm (1-1/2 in.) high and raised a minimum of 0.75 mm (1/32 in.). Permanently attached plates are acceptable. If the system uses a handset, then the length of the cord from the panel to the handset shall be minimum 735 mm (29 in.). Additionally, the handset shall be equipped with a receiver that generates a magnetic field in the area of the receiver cap, and the handset shall have a volume control and shall comply with CSA Standard T515. If the system is located in a closed compartment, the compartment

door and hardware shall conform to 4.4.2. The emergency intercommunication system shall not require voice communication.

Lighting in elevator cabs shall be minimum 100 lux (9.2 ft-candles), measured at the floor level and at the same lighting level as the adjacent lobby *space*.

Mirrors shall be provided to assist individuals using mobility devices to back out of an elevator where there is insufficient space within the cabin to turn around.

Mirrors shall not be used below a height of 2000 mm (78-3/4 in.) within elevator cabs as a finish material on the wall opposite the door.

Where the dimension of elevator cabs is less than 1500 mm (59 in.) in any direction, an angled mirror shall be provided above a height of 2000 mm (78-3/4 in.) on the wall opposite the door, to assist persons who use wheelchairs to back out.

Floor finishes within elevator cabs shall comply with 4.1.2.

Where an elevator serves only two floors, it shall be programmed to move automatically, without the need to activate in-car control buttons.

Elevator doors shall incorporate pronounced *colour contrast*, to differentiate them from the surrounding environment.

There shall be a pronounced *colour contrast* between the car sill and the *facility* floor.

## **RELATED SECTIONS**

4.1.1 Space and Reach Requirements

4.1.2 Ground and Floor Surfaces

4.1.6 Doors

4.1.12 Handrails

4.1.15 Platform Lifts

4.4.2 Controls and Operating Mechanisms

4.4.7 Signage

4.4.9 Public Address Systems

4.4.11 Card Access, Safety and Security Systems

4.4.12 Glare and Light Sources

4.4.13 Lighting

4.4.14 Materials and Finishes

## 4.4.15 Texture and Colour

**4.1.15 PLATFORM LIFTS****RATIONALE**

Platform lifts are typical in retrofit applications. Elevators that are used by all facility users are preferred to platform lifts which tend to segregate persons with disabilities and limit space at *entrance* and stair locations. Furthermore, independent access is often compromised, as platform lifts are often controlled by key operation. Whenever possible, grading or integrated elevator access should be incorporated to avoid the use of lifts.

If there are no suitable alternatives, lifts must be selected to permit the spatial requirement of larger mobility devices such as scooters.

**APPLICATION**

*Accessible* platform lifts shall comply with this section. Platform lifts may only be used in lieu of an elevator or *ramp* where allowable under 4.1.14.

Exception: Where it is *technically infeasible* to install an elevator, LU/ LA (Limited Use/Limited Application) elevating device, or other *accessible* means of change of level.

**DESIGN REQUIREMENTS**

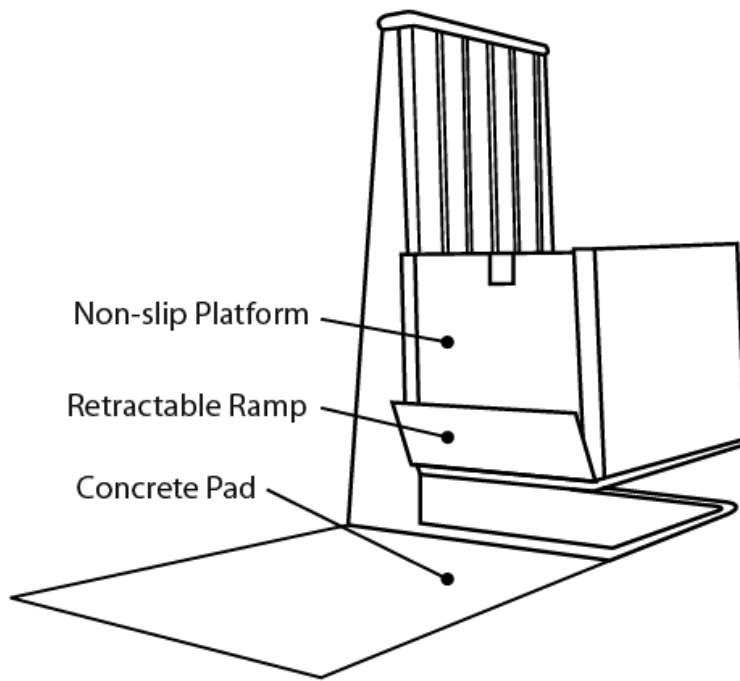
*Accessible* platform lifts shall

- be on an *accessible route* complying with 4.1.4;
- be identified with *signage* complying with applicable provisions of 4.4.7;
- comply with CSA standard CAN/ CSA B355 (latest edition); and
- facilitate unassisted entry, operation, and exit from the lift.

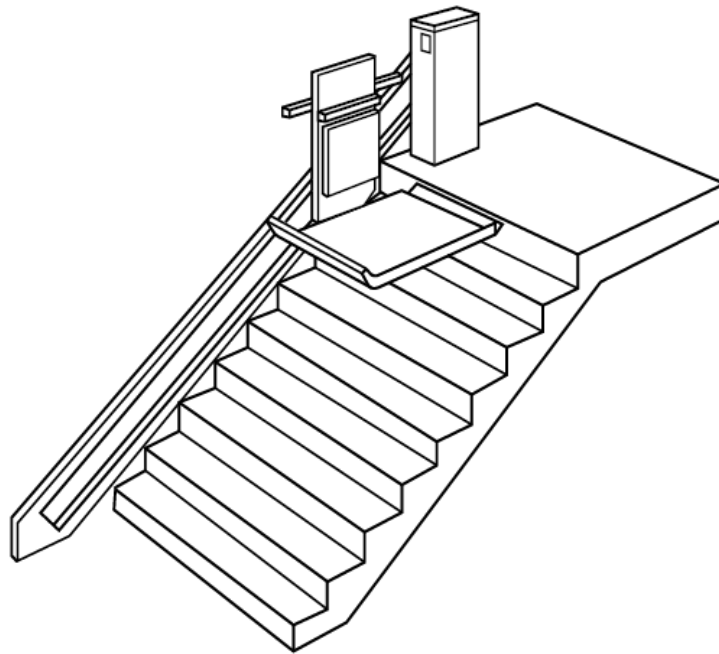
The platform size shall be no less than 890 x 1525 mm (35 x 60 in.). The platform shall incorporate safety wheel-guards along all exposed edges. The doors to the platform lift shall comply with 4.1.6. Controls and operating mechanisms shall comply with 4.4.2.

Platform lifts shall be linked by an emergency call system to a monitored location within the *facility*, with two-way communication ability. The highest *operable portion* of the two-way communication system shall be a maximum of 1200 mm (47 in.) from the floor of the platform. If the system uses a handset, then the length of the cord from the panel to the handset shall be at least 735 mm (29 in.). If the system is located in a closed compartment, the compartment door and hardware shall conform to 4.4.2.

Floor finishes within platform lifts shall comply with 4.1.2 and 4.4.14.



**Figure 4.1.15.1** Vertical Platform Lift



**Figure 4.1.15.2** Inclined Platform Stair-Lift

**RELATED SECTIONS**

4.1.1 Space and Reach Requirements

4.1.2 Ground and Floor Surfaces

4.1.6 Doors

4.1.12 Handrails

4.1.14 Elevators

4.4.2 Controls and Operating Mechanisms

4.4.7 Signage

4.4.9 Public Address Systems

4.4.11 Card Access, Safety and Security Systems

4.4.12 Glare and Light Sources

4.4.13 Lighting

4.4.14 Materials and Finishes

4.4.15 Texture and Colour

## 4.2 WASHROOM FACILITIES

### 4.2.1 TOILET FACILITIES

#### RATIONALE

As an integral feature of a *facility*, washroom *facilities* should accommodate the range of people that will use the space. Although many persons with disabilities use toilet *facilities* independently, some may require assistance. Where the individual providing assistance is of the opposite gender then typical gender-specific washrooms are awkward and a Universal Washroom is preferred.

Parents and caregivers with small children and strollers may also benefit from a large Universal Washroom with toilet and change *facilities* contained within the same *space*.

Circumstances such as wet surfaces and the act of transferring between toilet and wheelchair or scooter can make toilet *facilities* accident-prone areas. An individual falling in a washroom with a door that swings inward could prevent his or her rescuers from opening the door. Due to the risk of accidents, design decisions such as door swings and material finishes have safety implications and therefore make toilet *facilities* a prime location for emergency call switches. The appropriate design of all features will increase the usability and safety of all toilet *facilities*.

The identification of washrooms involves design issues that must be considered. For children or someone who cannot read text, a symbol or pictogram is preferred. A person with a visual *impairment* would also benefit from accessible *signage*. Features such as *colour contrasting* door frames and door hardware will also increase accessibility.

**APPLICATION**

Where toilet *facilities* are provided, each public or *common use* toilet *facility* shall comply with this section. Other toilet rooms provided for the use of occupants of specific *spaces* (i.e. a private toilet room for the occupant of a private office) shall be *adaptable*.

In a retrofit situation where it is *technically infeasible* to make existing public or *common use* toilet *facilities accessible*, the installation of at least one Universal Washroom per floor and in compliance with 4.2.7, located in the same area as existing toilet *facilities*, will be permitted in lieu of modifying existing toilet *facilities* to be *accessible*.

In addition to any *accessible* public or *common use* toilets, at least one Universal Washroom in compliance with 4.2.7 shall be provided in all public buildings and on every floor level in *assembly areas* where the floor incorporates *common* or *public use* washroom *facilities* containing four or more toilet and/or urinal fixtures.

If Universal Washrooms are not visible from the common or *public use* washrooms, directional *signage* in compliance with 4.4.7 shall be provided.

Where bathing *facilities* are provided on a *site*, in conjunction with or in addition to toilet *facilities*, each such public or *common use* bathing *facility* shall comply with this section in addition to 4.2.8, 4.2.9, and other applicable sections of this standard.

For single-user portable toilet units clustered at a single location, a minimum of 5% but no less than one toilet unit in compliance with this section shall be provided at clusters wherever typical inaccessible units are provided. (Exception: Portable toilet units at construction sites used exclusively by construction personnel are not required to comply with this section.)

Where a Universal Washroom is provided primarily for the use of persons of both genders with physical *disabilities*, in lieu of *facilities* for persons with physical *disabilities* in washrooms used by the general public, the Universal Washroom shall be provided on the same floor level within 45 m (147 ft. 8 in.) of the washrooms used by the general public.

**Table 4.2.1** Minimum number of Universal Washrooms per building

| <b>Number of Storeys in Building</b> | <b>Minimum number of Universal Washrooms per Building</b>                   |
|--------------------------------------|---|
| 1 to 3                               | 1   |
| 4 to 6                               | 2   |
| Over 6                               | 3, plus 1 for each additional increment of 3 storeys in excess of 6 storeys |

**DESIGN REQUIREMENTS**

*Accessible* toilet *facilities* shall

- be on an *accessible route* complying with 4.1.4;
- be identified with *signage* complying with applicable provisions of 4.4.7;
- incorporate a *clear floor space* to allow a person in a wheelchair to make a 180-degree turn; and

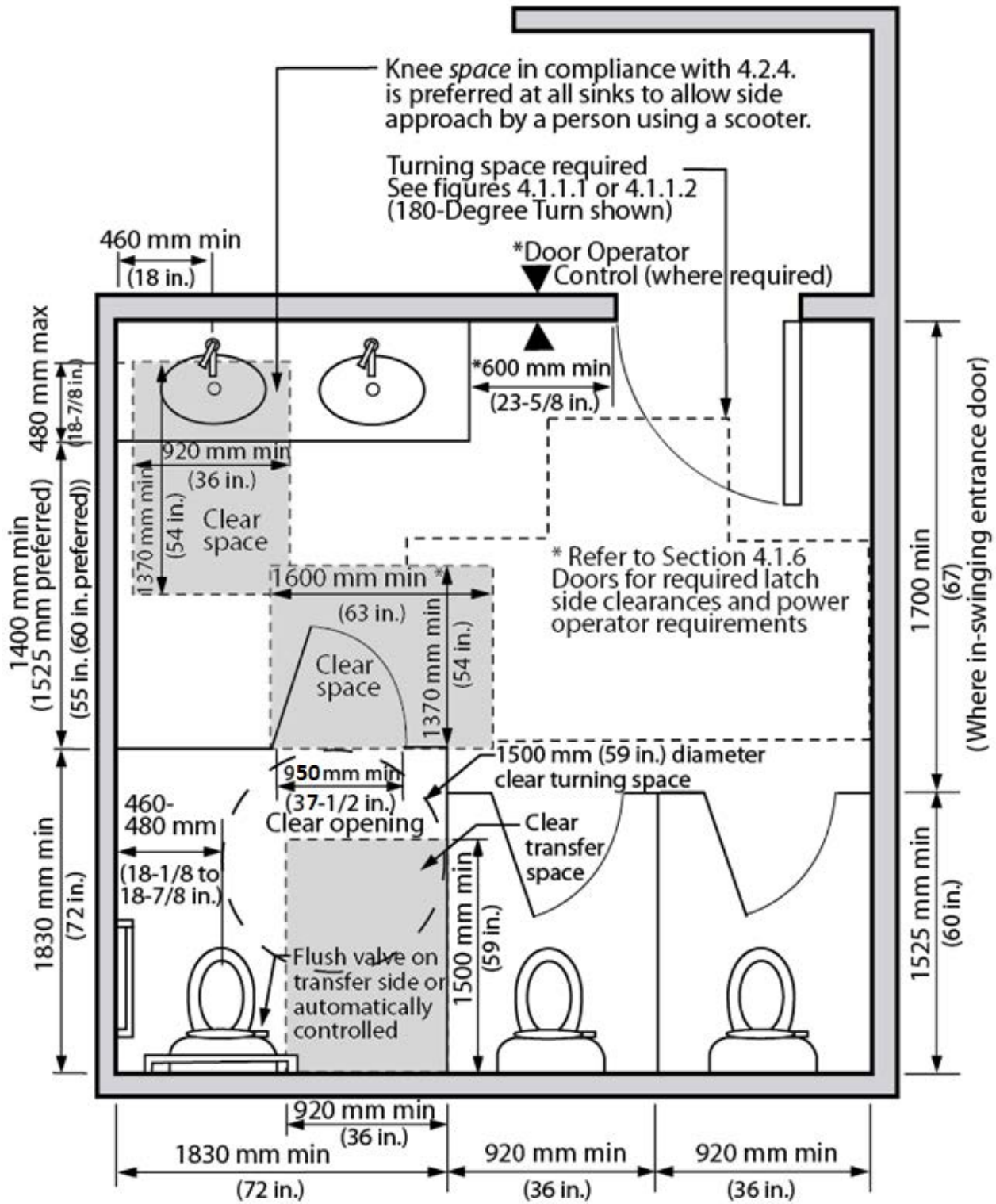
- incorporate even illumination throughout of at least 100 lux (20 ft-candles).

All entrance doors to *accessible* toilet rooms shall

- comply with 4.1.6;
- not swing into the *clear floor space* required for any fixture; and
- have a minimum 1700 mm (67 in.) clearance between the inside face of an in-swinging entrance door and the outside face of an adjacent toilet stall.

*Accessible* fixtures and controls within toilet and bathing rooms shall

- have a minimum clearance of 1525 mm (60 in.) between the outside face of the *accessible* stall and any wall-mounted fixture or obstruction (in a retrofit situation where it is technically infeasible to provide a 1525 mm (60 in.) clearance, this measurement may be reduced to 1400 (55 in.)); and
- be on an accessible route complying with 4.1.4.



Refer to Section 4.2.2 Toilet Stalls for accessible toilet stall requirements.

Figure 4.2.1.1 Washroom Dimensions



## RELATED SECTIONS

- 4.1.1 Space and Reach Requirements
- 4.1.2 Ground and Floor Surfaces
- 4.1.3 Protruding and Overhead Objects
- 4.1.6 Doors
- 4.2.2 Toilet Stalls
- 4.2.3 Toilets
- 4.2.4 Lavatories
- 4.2.5 Urinals
- 4.2.6 Washroom Accessories
- 4.2.7 Universal Washrooms
- 4.2.8 Bathtubs
- 4.2.9 Shower Stalls
- 4.2.10 Grab Bars
- 4.4.2 Controls and Operating Mechanisms
- 4.4.7 Signage
- 4.4.12 Glare and Light Sources
- 4.4.13 Lighting
- 4.4.14 Materials and Finishes
- 4.4.15 Texture and Colour

## 4.2.2 TOILET STALLS

### RATIONALE

Maneuverability of a wheelchair or scooter is the principal consideration in the design of an *accessible* stall. The increased size of the stall is required to ensure there is sufficient *space* to facilitate proper placement of a wheelchair or scooter to accommodate transfer onto the toilet fixture. Not only is *space* required for mobility equipment, there may also be instances where an individual requires assistance and the stall will have to accommodate a second person.

Door swings are normally outward for safety reasons and *space* considerations, but this makes it difficult to close the door once inside. A handle mounted part way along the door makes it easier for someone to close the door behind them.

Minimum requirements for non-*accessible* toilet stalls are included to ensure that persons who do not use wheelchairs or scooters can be adequately accommodated within any toilet stall. Universal features include *accessible* hardware and a minimum stall width to accommodate persons of large stature or parents with small children.

**APPLICATION**

*Accessible* toilet stalls shall comply with this section.

Where toilet stalls are provided in a toilet or bathing *facility*, then the number of *accessible* toilet stalls designated to accommodate persons with *disabilities* shall comply with Table 4.2.2.

All other toilet stalls within a *facility* (i.e., those considered to be non-*accessible*) shall be minimum 920 mm (36 in.) wide by 1525 mm (60 in.) long, and shall incorporate door-locking mechanisms in compliance with this section.

| <b>Table 4.2.2 Number of accessible toilet stalls</b> |   |
|---|---|
| <b># of toilet stalls within the washroom</b>         | <b>Required # of accessible toilet stalls</b> |
| 1-5   | 1   |
| 5-16  | 2   |
| 17-20   | 3   |
| 21-30   | 4   |
| Over 30   | 5 plus 1 for each additional increment of 10  |

**DESIGN REQUIREMENTS**

All toilet stall doors shall be capable of being locked from the inside by a device that is operable with a closed fist, and requires a force of not more than 22.2 N (4.9 lb.) to activate.

*Accessible* toilet stalls shall

- be on an *accessible route* in compliance with 4.1.4;
- have internal dimensions at least 1830 x 1830 mm (72 x 72 in.);
- have a clear turning space within the stall of at least 1500 mm (59 in.) in diameter;
- have a toilet fixture in compliance with 4.2.3;
- be equipped with a collapsible coat hook mounted not more than 1200 mm (47 in.) above the floor on a side wall and projecting not more than 50 mm (2 in.) from the wall;
- have a minimum 920 mm (36 in.) wide x 1500 mm (59 in.) deep *clear transfer space* on one side of the toilet fixture;
- be equipped with L-shaped grab bars on one side of the toilet in compliance with 4.2.3 and 4.2.10; and
- Where more than one *accessible* toilet stall is provided within a toilet or bathing *facility*, the stalls shall be configured with the *clear transfer space* (i.e., the *open space* beside the toilet) on opposite sides of the toilet fixtures.

Every toilet stall door shall

- be capable of being locked from the inside with a closed fist using a force of not more than 22.2 N (4.9 lb.) to activate; and
- incorporate lock hardware that is capable of being released from the outside in case of an emergency

Accessible toilet stall doors shall:

- provide a clear opening of at least 950 mm (37-1/2 in.) with the door in the open position. In a retrofit situation where it's *technically infeasible* to provide the required *clear* opening, the *clear* opening may be reduced to 860 mm (34 in.);
- swing outward, unless additional clear floor space of at least 920 mm x 1500 mm (36 in. x 59 in.) is provided within the stall and does not interfere with the arc of the door swing;
- allow outside access after alarm is pulled;
- be aligned with the *clear transfer space* adjacent to the toilet fixture;
- be equipped with gravity hinges so that the door closes automatically;
- be provided with a “D”-type *contrasting* coloured door pull, at least 140 mm (5-1/2 in.) long, on the inside of an out-swinging door, located so that the centre line is between 200 and 300 mm (7-7/8 in. and 11- 3/4 in.) from the hinged side of the door mounted between 750 - 850 mm (29-1/2 - 33 in.); and
- be provided with a “D”-type contrasting-coloured door pull at least 140 mm (5-1/2 in.) long, on both sides of the door, located near the latch mounted between 750 - 850 mm (29-1/2 - 33 in.).

Door hardware (operating devices such as handles, pulls, latches, and locks) shall be designed to be operable using a closed fist, require a force of not more than 22.2 N (4.9 lb.) to activate and located at a height not less than 900 mm (35-1/2 in.) and not more than 1100 mm (43 in.) above the finished floor.

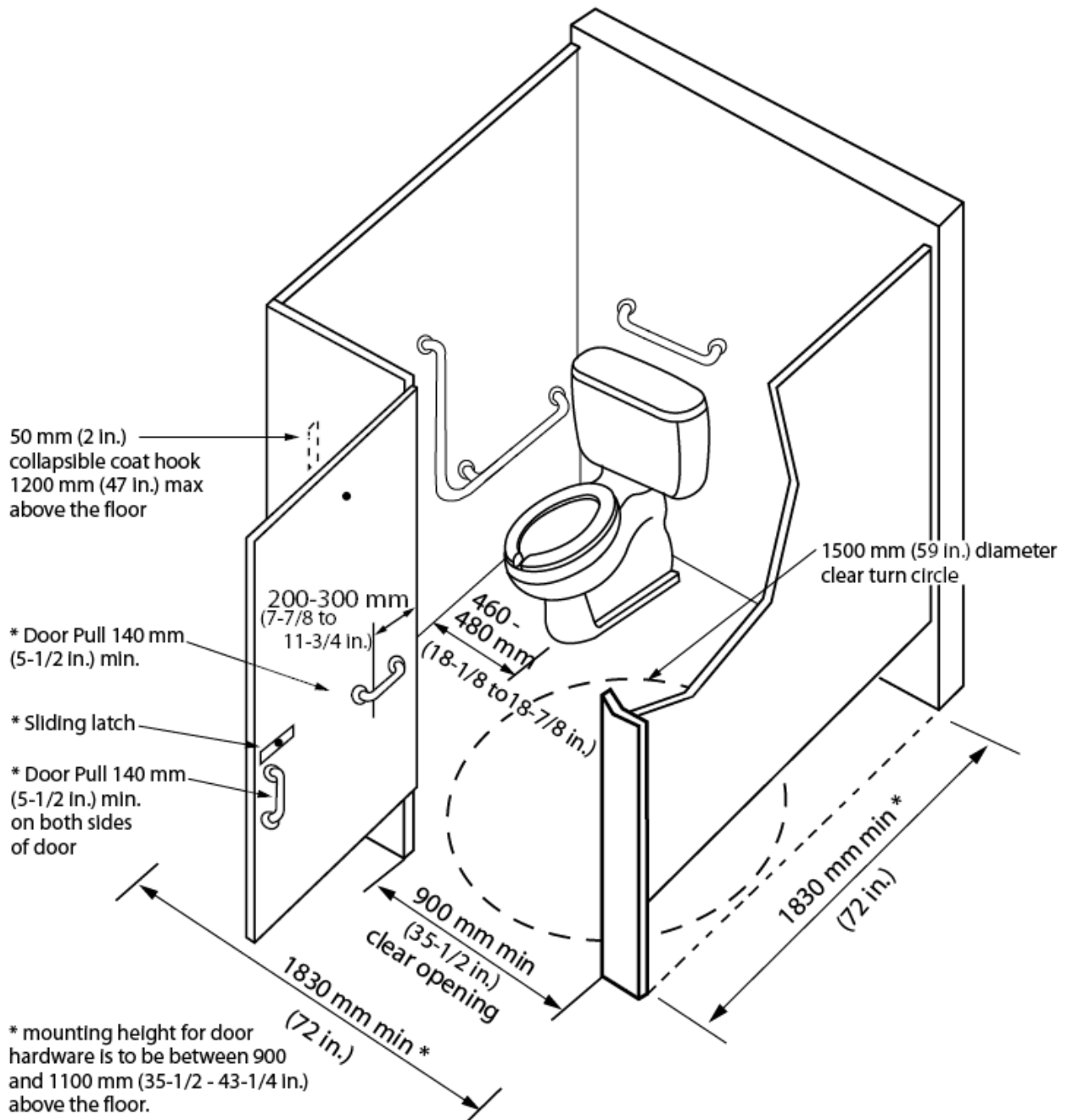
Toilet stall partitions and doors shall be *colour contrasted* with the surrounding environment.

Where an airport style (door-free) washroom entry is used, the set-back wall shall be painted a *contrasting colour* for easier depth perception and entry wayfinding.

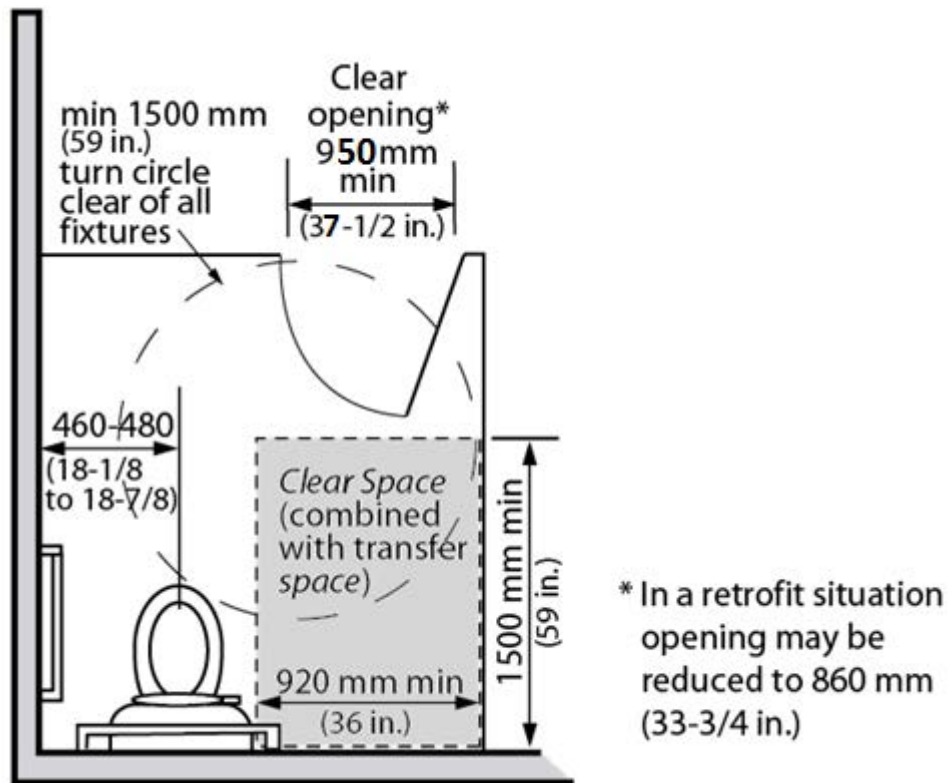
Designated ambulatory toilet stalls shall

- be at least 1500 mm (59 in.) deep and 920 - 940 mm (36 - 37 in.) wide;
- have the toilet fixture centred between the partition walls;
- have a door that provides a clear opening width of at least 810 mm (32 in.), which swings out unless the minimum stall dimensions are not located within the door swing;
- be equipped with gravity hinges;
- have latch-side “D”-type contrasting-coloured door pulls in compliance with this section; and
- be equipped with an L-shaped grab bars on one side of the toilet and a horizontal grab bar behind the toilet in compliance with 4.2.3 and 4.2.10

Toilets, flush controls and other *elements* shall be designed to meet the requirements of 4.2.3.



**Figure 4.2.2.1 Accessible Toilet Stall**



**Figure 4.2.2.2** Accessible Toilet Stall with In-Swinging Door

## RELATED SECTIONS

- 4.1.1 Space and Reach Requirements
- 4.1.3 Protruding and Overhead Objects
- 4.1.6 Doors
- 4.2.3 Toilets
- 4.2.6 Washroom Accessories
- 4.2.10 Grab Bars
- 4.4.2 Controls and Operating Mechanisms
- 4.4.13 Lighting
- 4.4.15 Texture and Colour

## 4.2.3 TOILETS

### RATIONALE

Automatic flush controls are preferred. If flushing mechanisms are not automated, then consideration must be given to the ability to reach a switch and the hand strength or dexterity required to operate it. Lever style handles on the transfer side of the toilet facilitate these considerations.

Appropriate placement of grab bars makes sitting and standing or transfers between the toilet and a mobility device safer.

### APPLICATION

*Accessible* toilets shall comply with this section.

### DESIGN REQUIREMENTS

Toilet fixtures shall have

- the top of the seat between 430 and 460 mm (17 and 18-1/8 in.) above the floor;
- no spring-activated seat;
- a back support where there is no seat lid or tank; and
- the tank top securely attached.

Toilets shall be located so that

- the centre line of the toilet is not less than 460 mm (18-1/8 in.) and not more than 480 mm (18-7/8 in.) from one side wall, and a clear transfer space at least 900 mm (35-1/2 in.) wide and 1500 mm (59 in.) deep is provided on the other side of the water closet, or
- a clear transfer space at least 900 mm (35-1/2 in.) wide and 1500 mm (59 in.) deep is provided on one side of the toilet.

The *clear transfer space* shall be clear of obstructions (such as garbage bins or baby change tables).  
EXCEPTION: Sanitary napkin disposal units may be installed within the transfer space provided they are recessed or protrude not more than 100 mm (3-15/16 in.) into this space.

Toilet flush controls shall be operable using a closed fist with a force of not more than 22N and located on the transfer side of the toilet; or be electronically automatically controlled.

Hand-operated flush controls shall comply with 4.4.2.

Toilets shall be equipped with grab bars that shall

- comply with 4.2.10;
- be L-shaped with 750 mm (30 in.) long horizontal and vertical components mounted with the horizontal component 750 mm - 810 mm (29-1/2 - 32 in.) above the floor and the vertical component 150 mm (5-7/8 in.) in front of the toilet bowl; and
- be at least 600 mm (23-5/8 in.) in length, mounted horizontally on the wall behind the toilet, from 840 mm (33 in.) to 920 mm (36 in.) above the floor, and, where the water closet has a water tank, be mounted minimum 150 mm (5-7/8 in.) above the tank.

Note: An optional drop-down grab bar in compliance with this section may be provided on the transfer side of the toilet.

Where provided, a drop-down grab bar shall

- be mounted on the wall behind the water closet
  - with the horizontal component 750 mm (29-1/2 in.) above the finished floor; and
  - not less than 390 mm (15-3/8 in.) and not more than 410 mm (16-1/8 in.) from the centre line of the water closet;
- not require a force of more than 22.2 N to pull it down;
- be at least 750 mm (30 in.) in length;
- be installed to resist a load of at least 1.3 kN applied vertically or horizontally;
- be not less than 35 mm (1-3/8 in.) and not more than 40 mm (1-1/2 in.) in diameter; and
- have a slip-resistant surface.

Where an accessible toilet stall is not located adjacent to a wall it shall be equipped with drop-down grab bars on each side,

- that comply with 4.2.10;
- that are at least 750 mm (30 in.) long;
- that are mounted on the wall behind the toilet with the horizontal component 750 mm (29-1/2 in.) above the finished floor and 390 - 410 mm (15-3/8 - 16-1/8 in.) from the centre line of the toilet; and
- one of which will have the toilet paper dispenser attached.

Designated ambulatory toilet stalls shall have L-shaped grab bars on both sides in compliance with this section.

Toilet-paper dispensers shall be wall mounted; and

- located below the grab bar;
- have an operable portion in line with or not more than 300 mm (11-3/4 in.) in front of the toilet seat;
- have an operable portion not less than 600 mm (23-5/8 in.) above the floor; and
- *contrasting* in colour to the wall.

Note: single large roll dispensers are required, as it can be difficult to reach the outside roll of conventional double roll dispensers.

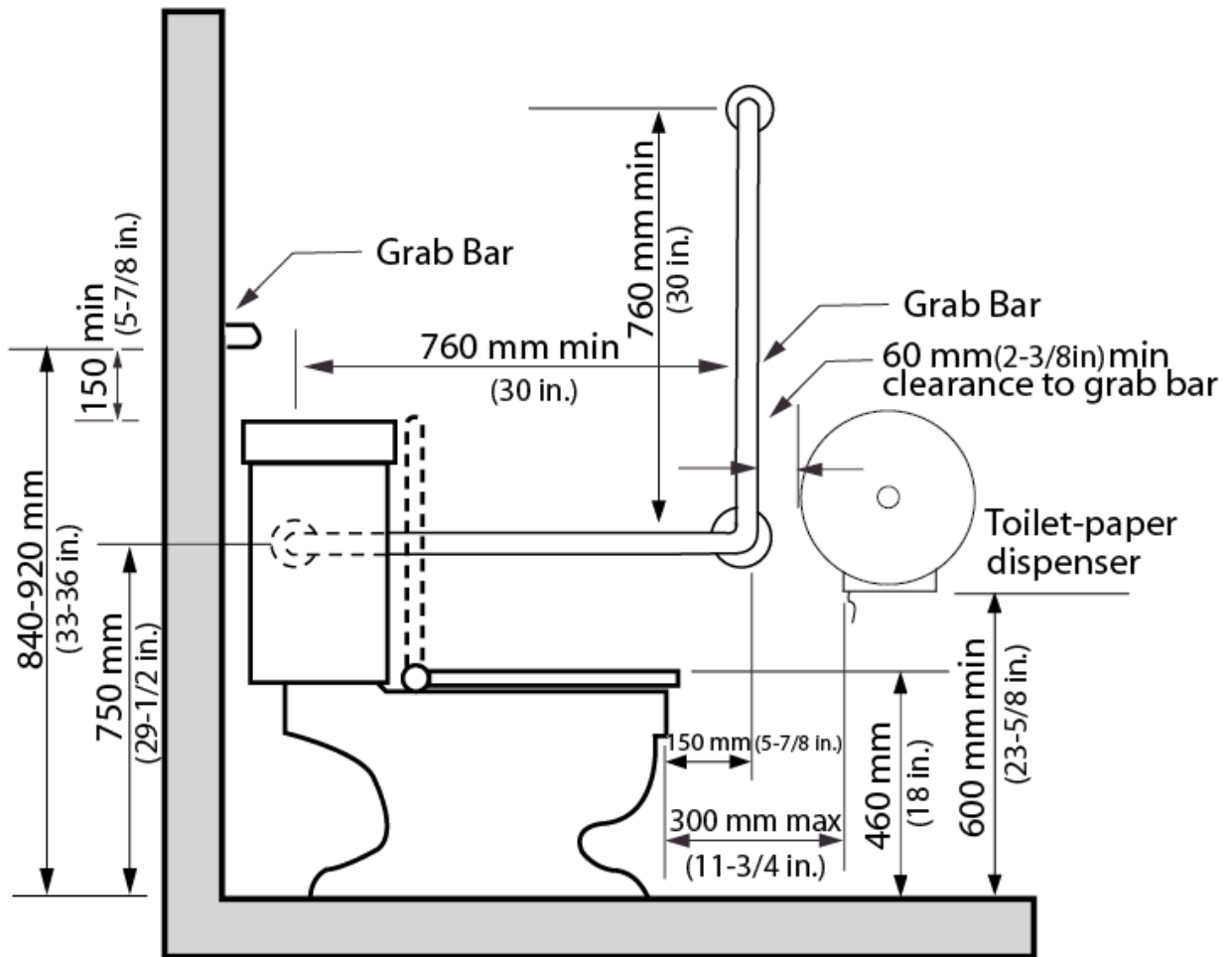


Figure 4.2.3.1 Grab Bar Configuration

**RELATED SECTIONS**

- 4.1.1 Space and Reach Requirements
- 4.2.2 Toilet Stalls
- 4.2.10 Grab Bars
- 4.4.2 Controls and Operating Mechanisms
- 4.4.13 Lighting
- 4.4.15 Texture and Colour



## 4.2.4 LAVATORIES

### RATIONALE

The accessibility of lavatories will be greatly influenced by their operating mechanisms. While faucets with remote-eye technology may initially confuse some individuals, their ease of use is notable. Individuals with hand strength or dexterity difficulties can use lever-style handles. For an individual in a wheelchair, a lower counter height and clearance for knees under the counter would be required. This lower counter may also serve children. The insulating of hot water pipes protects the legs of an individual using a wheelchair. This is particularly important when a disability impairs sensation such that the individual would not sense that their legs were being burned. The combination of shallow sinks and higher water pressures can cause unacceptable splashing at lavatories.

### APPLICATION

All lavatories shall comply with this section. In a retrofit situation where it is *technically infeasible* to have all lavatories comply with this section, at least one lavatory in each *accessible* washroom shall comply.

### DESIGN REQUIREMENTS

Lavatories shall

- be on an accessible route complying with 4.1.4.;
- be mounted so that the minimum distance between the centre line of the fixture and the side wall is 460 mm (18-1/8 in.);
- have the top located between 820 mm (32-1/4 in.) and 840 mm (33 in.) above the floor;
- have a knee *space* of at least 920 mm (360 in.) wide; 735 mm (29 in.) high at the front edge;
- be 685 mm high (27 in.) at a point 205 mm (8-1/8 in.) back from the front edge; and 350 mm (13-3/4 in.) high over the distance from a point 280 mm (11 in.) to a point 430 mm (16-7/8 in.) back from the front edge; See figure 4.2.4.1
- have a minimum *clear floor space* 760 mm wide (30 in.) and 1370 mm (54 in.) deep, of which a maximum of 500 mm (19-1/2 in.) in depth may be under the lavatory;
- have hot water and drain pipes insulated if they abut the clearances noted above, or limit the water temperature to a maximum of 43 degrees Celsius (100 degrees F); and
- have soap and towel dispensers that are
  - located to be accessible to persons who use wheelchairs or scooters (i.e., not having to reach over the lavatory to access the devices);
  - located so that the dispensing height is between 900 - 1100 mm (35-1/2 – 43-1/4) and located not more than 610 mm (24 in.), measured horizontally, from the edge of the lavatory;
  - operable with one hand;
  - *colour contrasted* from the surrounding environment; and
  - in compliance with 4.4.2.

Faucets and other controls shall

- be in compliance with 4.4.2;

## Exhibit A

- have lever-style handles (without spring loading) operable with a clenched fist, or be electronically controlled; and
- be located so that the distance from the centre line of the faucet to the edge of the basin, or where the basin is mounted in a vanity, to the front edge of the vanity is not more than 485 mm (19-1/8 in.).

The front apron of a vanity shall have a minimum clearance of 760 mm (30 in.) wide by 735 mm (29 in.) high.

Where a shelf is installed above a lavatory it shall be located not more than 200 mm (7-7/8 in.) above the top of the lavatory and not more than 1100 mm (43 in.) above the finished floor, and project not more than 100 mm (3-15/16 in.) from the wall.

Where mirrors are provided at lavatories or vanity units, they shall comply with 4.2.6.

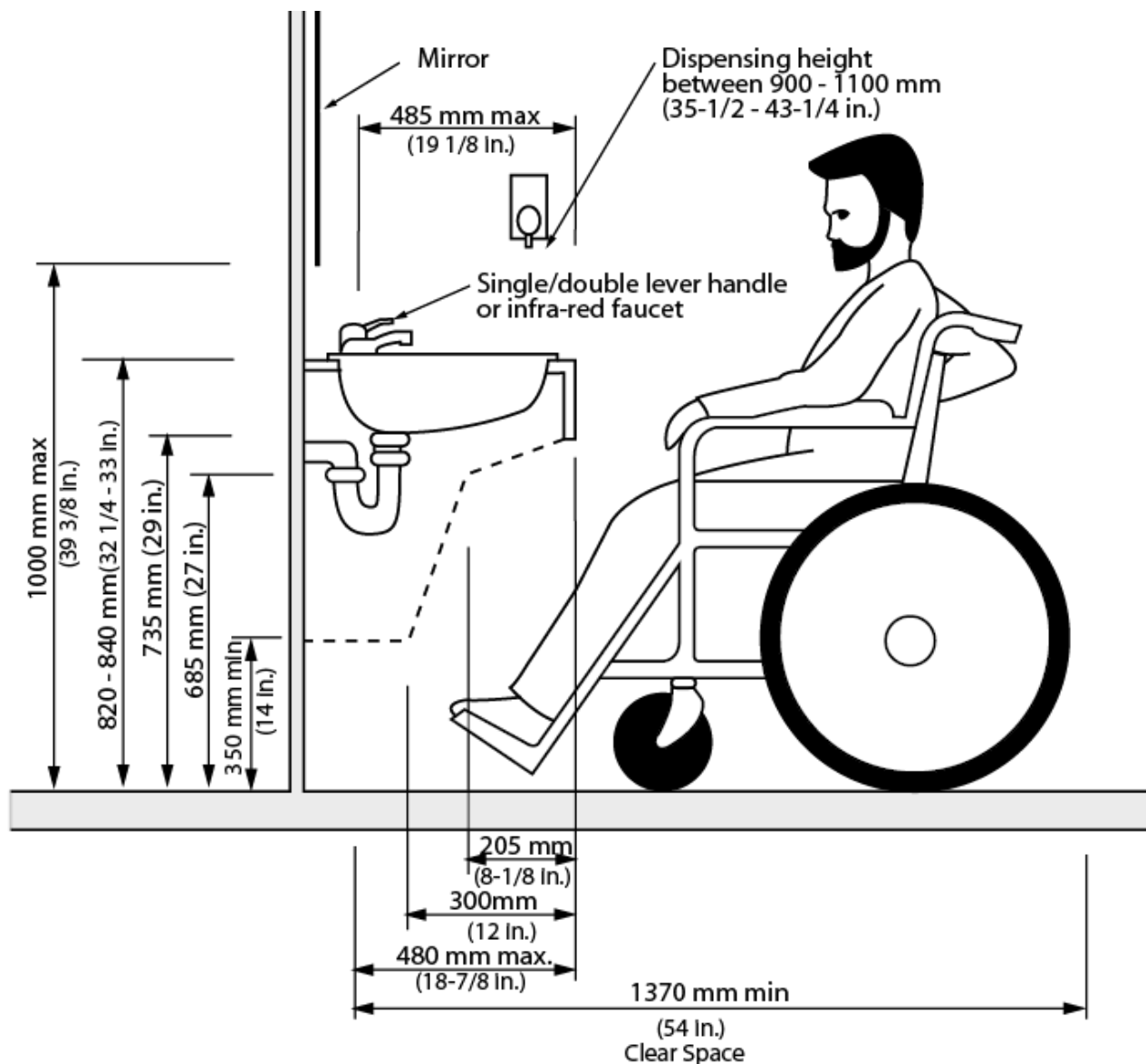


Figure 4.2.4.1 Lavatory Criteria

## RELATED SECTIONS

4.1.1 Space and Reach Requirements

4.2.2 Toilet Stalls

4.4.13 Lighting

4.4.15 Texture and Colour

## 4.2.5 URINALS

### RATIONALE

A *clear floor space* is required in front of urinals to maneuver a mobility device. The provision of grab bars may assist an individual in rising from a seated position and to steady themselves. Floor-mounted urinals accommodate children and persons of short stature as well as enable easier access to drain personal care devices. Flush controls should be lever-style or automatic (preferred).

Strong *colour contrasts* between the urinal, the wall and the floor will assist persons with a visual *impairment*.

### APPLICATION

Where urinals are provided in an *accessible* toilet or bathing *facility*, at least one shall comply with this section.

### DESIGN REQUIREMENTS

Urinals shall

- be designed at floor level with no step in front of the fixture;
- be wall-mounted with an elongated rim located no higher than 430 mm (17 in.) above the finished floor or floor mounted with the rim at the finished floor level;
- be at least 345 mm (13-1/2 in.) deep, measured from the outer face of the urinal rim to the back of the fixture;
- have a *clear floor space* of 810 mm x 1370 mm (32 in. x 54 in.) shall be provided in front of the urinal to allow for a forward approach. This *clear space* shall adjoin or overlap an *accessible route* and shall comply with 4.1.1.

Where privacy screens are provided

- there shall be at least 920 mm (36 in.) of clearance between them;
- they shall incorporate a pronounced *colour contrast*, to differentiate them from the surrounding environment, with a vertical outer edge that *contrasts* with the screen and the surrounding environment; and
- there shall be a clearance of at least 50 mm (2 in.) from the grab bar.

Urinals shall have grab bars installed on each side that

- comply with 4.2.10;
- are not less than 300 mm (23-5/8 in.) long; and
- are mounted vertically
  - not less than 380 mm (15 in.) and not more than 400 mm (15-3/4 in.) from the centre line of the urinal; and
  - with its centre line 1000 mm (39-3/8 in.) above the finished floor.

Flush controls shall be operable using a closed fist or automatic, mounted at no more than 1120 mm (44 in.) above the finished floor, and shall comply with 4.4.2.

Where a washroom contains more than two urinals, one urinal, other than the accessible urinal, shall be provided specifically for children that is installed with the rim no higher than 430 mm (17 in.) from the finished floor: or floor-mounted, with the rim level at the finished floor.

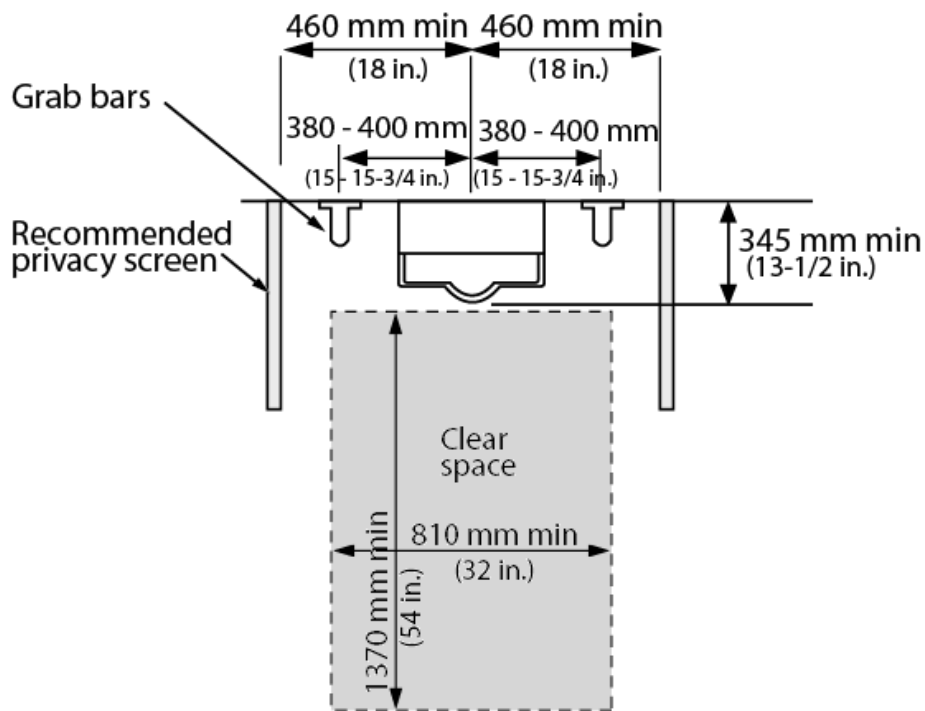


Figure 4.2.5.1 Urinal

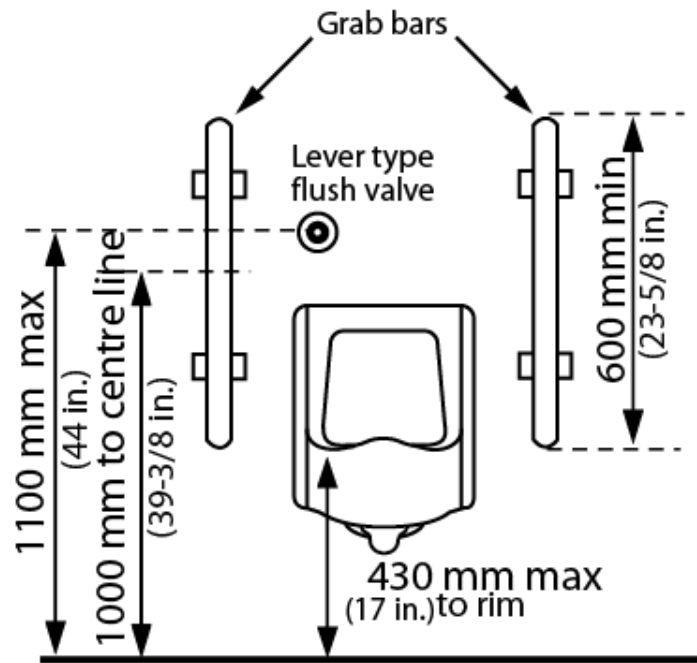


Figure 4.2.5.2 Urinal

## RELATED SECTIONS

- 4.1.1 Space and Reach Requirements
- 4.2.2 Toilet Stalls
- 4.4.13 Lighting
- 4.4.15 Texture and Colour

## 4.2.6 WASHROOM ACCESSORIES

### RATIONALE

Design issues related to washroom accessories include the hand strength and dexterity required to operate mechanisms. Reaching the accessories is another concern. Accessories that require the use of two hands to operate can present difficulties for a range of persons with disabilities when the ability to reach or balance is impaired. Section 4.4.2 addresses operating mechanisms in greater detail.

### APPLICATION

Where washroom accessories (such as hand-operated dispensers, hand-dryers, built-in garbage receptacles, etc.) are provided in a toilet or bathing *facility*, they shall comply with this section. In a retrofit situation where it is *technically infeasible* to make all washroom accessories comply with this

section, at least one of each type of washroom accessory shall comply in all *accessible* toilet or bathing *facilities*.

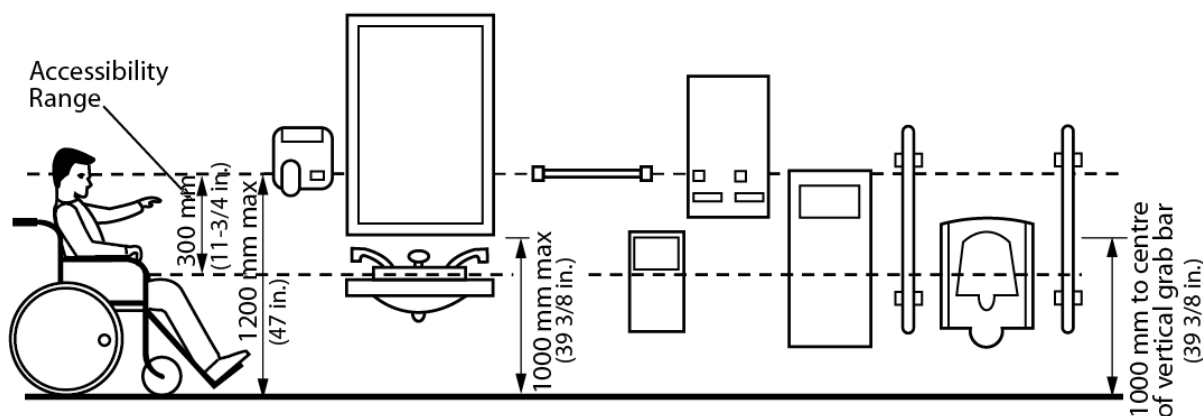
**DESIGN REQUIREMENTS**

Each type of washroom accessory provided, unless otherwise specified in 4.2.2 and 4.2.4, shall have *operable portions* and controls mounted between 900 mm (35-1/2 in.) and 1200 mm (47-1/4 in.) above the floor.

The operable controls and mechanisms of washroom accessories shall be operable using a closed fist or automatic and comply with 4.4.2.

Where mirrors are provided, at least one shall be

- mounted with its bottom edge not more than 1000 mm (39-3/8 in.) from the floor; or
- inclined from vertical to be usable by a person using a wheelchair.



**Figure 4.2.6.1 Washroom Accessories**

**RELATED SECTIONS**

- 4.1.1 Space and Reach Requirements
- 4.1.3 Protruding and Overhead Objects
- 4.4.2 Controls and Operating Mechanisms
- 4.4.13 Lighting
- 4.4.15 Texture and Colour

**4.2.7 UNIVERSAL WASHROOMS**

**RATIONALE**

The provision of a separate Universal Washroom is advantageous in a number of instances. For an individual using a wheelchair, the extra *space* provided with a separate washroom is preferred to an accessible stall. Should an individual require an attendant to assist them in the washroom then the

complication of a woman entering a men's washroom or vice versa is avoided. This same scenario would apply to a parent with a young child of a different gender.

In the event of an accident or fall by a single individual in this form of washroom, an emergency call switch and a means of unlocking the door from the outside are important safety features.

## **APPLICATION**

*Accessible* Universal Washrooms shall comply with this section.

At least one Universal Washroom, in addition to any *accessible public use* or *common use* toilets, shall be provided

- in all public buildings; and
- on every floor level in assembly buildings where the floor incorporates *common* or *public use* washroom *facilities* containing four or more toilet and/or urinal fixtures.

If Universal Washrooms are not visible from the *public use* or *common use* toilets, directional *signage* complying with 4.4.7 shall be provided.

The minimum number of universal washrooms per building shall be:

- 1 for buildings 1 - 3 storeys;
- 2 for buildings 4 - 6 storeys; or
- 3 for buildings over 6 storeys, plus 1 for each additional increment of 3 storeys.

## **DESIGN REQUIREMENTS**

*Accessible* Universal Washrooms shall

- be on an *accessible route* in compliance with 4.1.4;
- be identified with *signage* in compliance with applicable provisions of 4.4.7;
- be designed to permit a wheelchair/scooter to turn within an *open space* that has a diameter of not less than 2440 mm (96 in.). In a retrofit situation where providing the required turning *space* is *technically infeasible*, the turning space may be reduced to not less than 2130 mm (84 in.) with priority given to allow enough clear space between the toilet and the lavatory;
- be provided with a lavatory conforming to 4.2.4;
- be equipped with a toilet fixture conforming to 4.2.3 that is located
  - so that its centre line is not less than 460 mm (18-1/8 in.) and not more than 480 mm (18-7/8 in.) from an adjacent wall on one side; and
  - so that its centre line is not less than 1060 mm (42 in.) to any wall, fixture or other obstruction on the other side.
- be equipped with flush controls and other *elements* conforming to 4.2.3;
- be equipped with grab bars conforming to 4.2.3 and 4.2.10;
- have fixture clearances conforming to 4.2.3 and 4.2.4;
- be provided with a *clear transfer space* adjacent to the toilet fixture, as required by 4.2.3; and
- be equipped with

## Exhibit A

- a collapsible coat hook mounted not more than 1200 mm (47 in.) from the floor on a side wall and projecting not more than 50 mm (2 in.) from the wall;
- a mirror and washroom accessories complying with 4.2.6; and
- a shelf mounted not more than 1200 mm (47 in.) above finished floor and projecting not more than 100 mm (3-15/16 in.) from the wall;
- have lighting controlled by a motion sensor; and
- have where provided, drop-down grab bars shall comply with 4.2.3.

### *Accessible* Universal Washroom doors shall

- comply with 4.1.6;
- be equipped with a power operator;
- have a graspable latch operating and locking mechanism located not less than 900 mm (35-1/2 in.) and not more than 1000 mm (39-3/8 in.) above the floor;
- where equipped with a power locking mechanism, have:
  - a push-to-lock button on the inside;
  - a push-to-unlock button on the inside that also activates the power door operator;
  - signage indicating the door locking/unlocking procedures installed next to the locking/unlocking buttons;
  - a sign on the inside that is illuminated with the word “LOCKED” when the door is locked; and
  - a sign on the outside that is illuminated with the words “IN USE” when the door is locked;
- be capable of being locked from the inside with a closed fist without tight grasping, pinching, or twisting of the wrist with a force less than 22.2 N, and being released from the outside in case of emergency;
- be provided with a 'D'-type *contrasting* coloured door pull at least 140 mm (5-1/2 in.) long mounted on the inside of an out-swinging door so that its centre line is between 200 - 300 mm (7-7/8 - 11-3/4 in.) from the hinged side of the door and not more than 1000 mm (39-3/8 in.) and not less than 900 mm (35-7/16 in.) above the floor;
- if it is an out-swinging door, be equipped with a door closer, spring hinges or gravity hinges so that the door closes automatically; and
- be provided with a power door operator where the door is equipped with a self-closing device.

Where *accessible* Universal Washrooms are provided in assembly *buildings*, such as recreation centres, the washroom shall incorporate an emergency call system linked to a central monitoring location (e.g., office or switchboard). This system shall consist of audible and visual signal devices inside and outside of the washroom that are activated by a control device inside the washroom typically in reach of the toilet. An emergency sign shall be posted above the emergency button in letters at least 25 mm (1 in.) high with a 5 mm (3/16 in.) stroke that contains the words IN THE EVENT OF AN EMERGENCY PUSH EMERGENCY BUTTON AND AUDIBLE AND VISUAL SIGNAL WILL ACTIVATE.



Where power locking mechanisms are provided, activation of the emergency call system should release the locking mechanism to enable quick access to responders.

For park or facility washrooms, where there is no connection to a central monitoring location, localized visual and audible alarms shall be provided.

*Accessible* Universal Washrooms shall incorporate a change table which shall

- be at least 810 mm (32 in.) wide by 1830 (72 in.) long;
- incorporate an adjacent *clear floor space* not less than 900 mm (35-1/2 in.) along the entire length of the of the change table;
- be designed to carry a load of at least 1.33 kN (300 lbs.); Note: wherever feasible, every attempt shall be made to install a change table with the greatest feasibly attainable carrying load;
- have a surface height above the finished floor that can be adjusted (while the loading-bearing weight is applied) from between 450 mm (17-3/4 in.) and 500 mm (19-5/8 in.) at the low range to between 850 mm (33 in.) and 900 mm (35-1/2 in.) at the high range;
- be located on an *accessible route* in compliance with 4.1.4; and
- have, if of the fold-down type, no operable portions higher than 1200 mm (47 in.).

EXCEPTION: An adjustable height change table may be substituted with a non-adjustable change table if low frequency of use is expected or the non-adjustable change table offers a significantly greater load capacity. A non-adjustable change table shall comply with the above criteria except that it shall have a surface height between 450 mm (17-3/4 in.) and 500 mm (19-5/8 in.) above the finished floor.

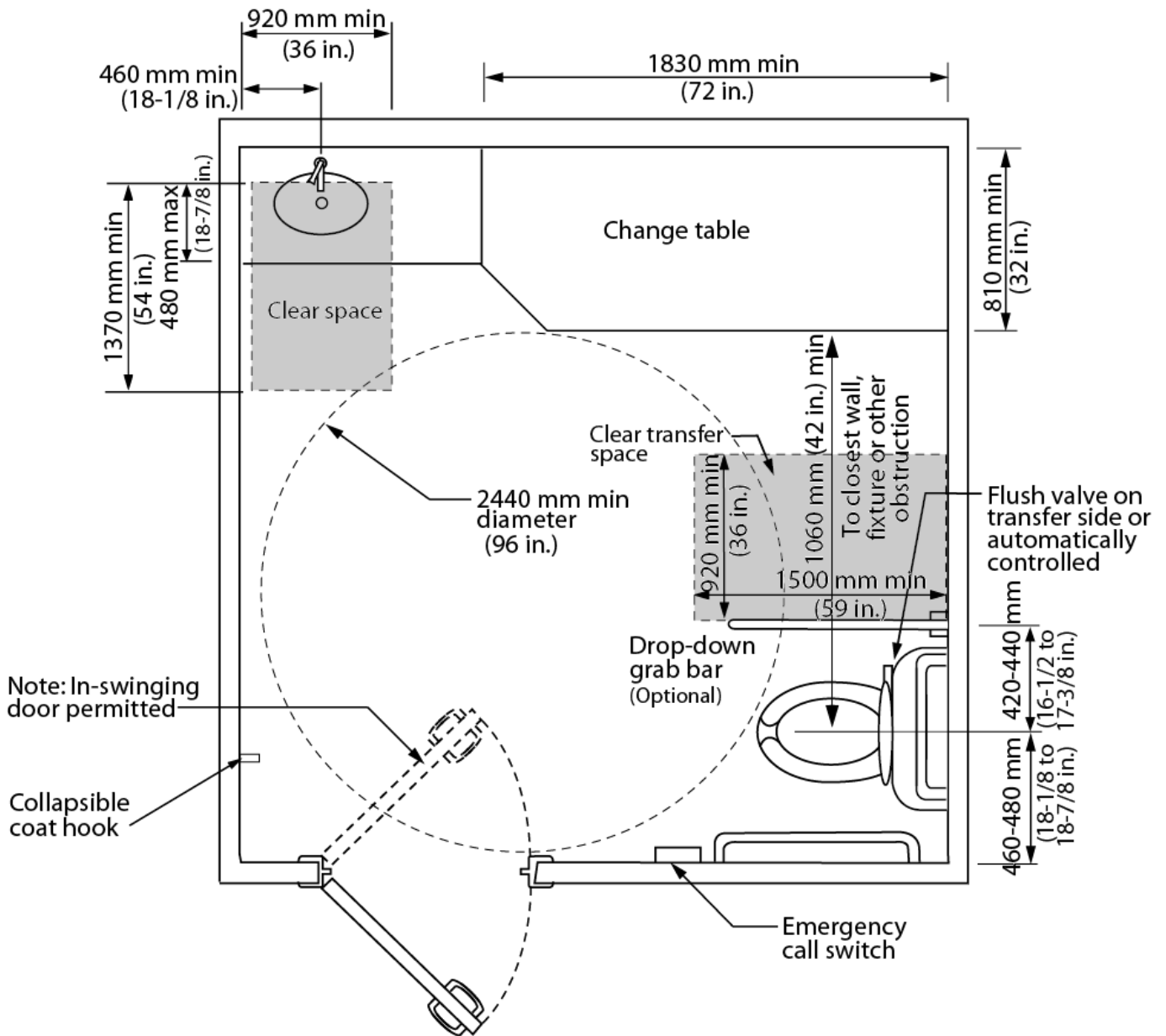
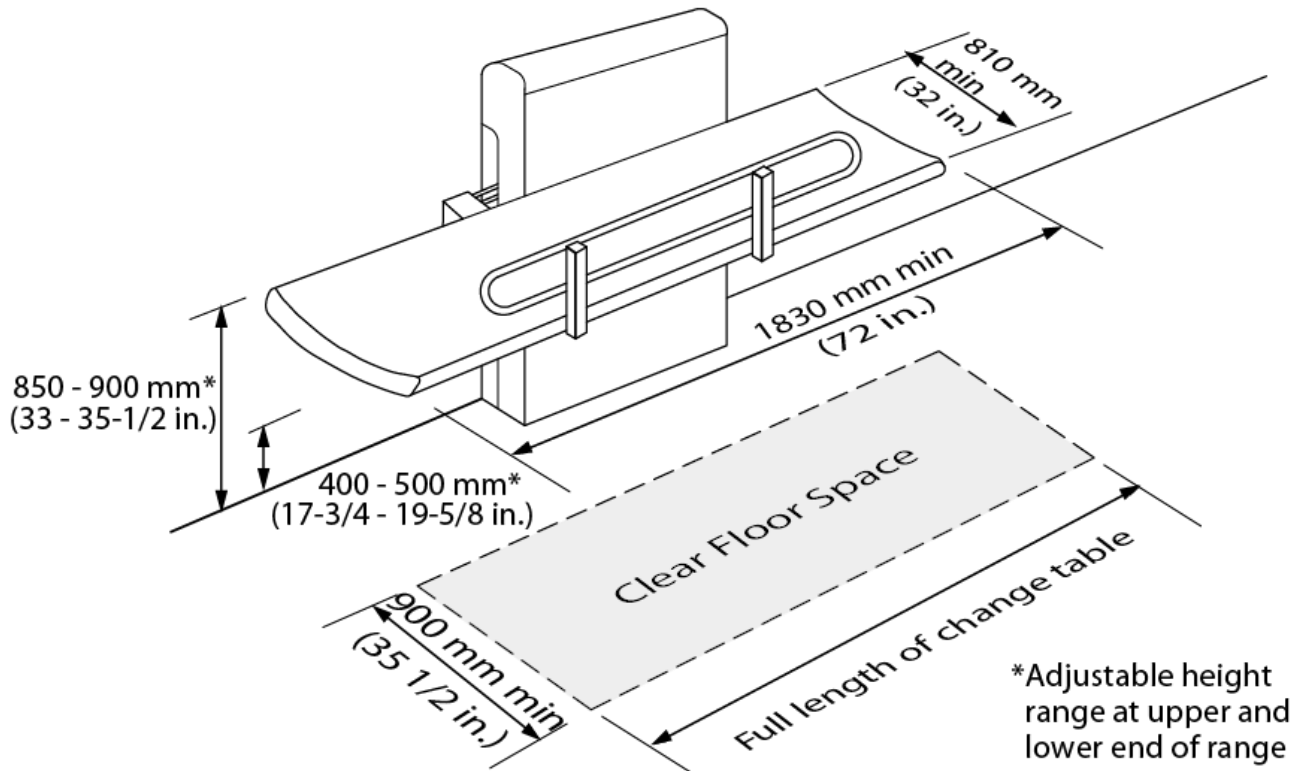


Figure 4.2.7.1 Universal Washroom



**Figure 4.2.7.2 Adult Change Table**

## RELATED SECTIONS

- 4.1.1 Space and Reach Requirements
- 4.1.2 Ground and Floor Surfaces
- 4.1.3 Protruding and Overhead Objects
- 4.1.6 Doors
- 4.2.3 Toilets
- 4.2.4 Lavatories
- 4.2.5 Urinals
- 4.2.6 Washroom Accessories
- 4.2.10 Grab Bars
- 4.4.2 Controls and Operating Mechanisms
- 4.4.7 Signage

## 4.4.11 Card Access, Safety and Security Systems

## 4.4.12 Glare and Light Sources

## 4.4.13 Lighting

## 4.4.14 Materials and Finishes

## 4.4.15 Texture and Colour

**4.2.8 BATHTUBS****RATIONALE**

Bathtubs can present a slipping hazard. Slip-resistant surfaces are an important feature and will benefit any individual, including those with *disabilities*. Grab bars also provide stability. Operating systems are subject to limitations in hand strength, dexterity and reach.

**APPLICATION**

Where bathtubs are provided, all bathtubs shall comply with this section. In a retrofit situation where it is *technically infeasible* to have all bathtubs comply with this section, at least 10%, but never less than one, in each bathing *facility* shall comply with this section.

**DESIGN REQUIREMENTS**

*Accessible* bathtubs shall

- be on an *accessible* route complying with 4.1.4;
- have a clear floor space at least 920 mm (36 in.) wide and 1440 mm (56-3/4 in.) long shall be provided along the full length of the bathtub; and
- have faucet handles
  - of the lever type that are not spring-loaded, or are automatically operable;
  - that are located so as to be usable by a person seated in the bathtub;
  - and other controls mounted not more than 450 mm (17-3/4 in.) above the bathtub rim.
- have a shower head complying with 4.2.9;
- unless the bathtub is freestanding, be equipped with an "L" shaped grab bar conforming to 4.2.10 mounted on the wall
  - with each leg of the "L" being at least 920 mm (36 in.) in length;
  - with the legs of the "L" being separated by a 90 degrees;
  - with the horizontal leg of the "L" being located 150 - 200 mm (5-7/8 - 7-7/8 in.) above and parallel to the rim of the bathtub; and
  - with the vertical leg of the "L" being located 300 - 450 mm (11-3/4 - 17-3/4 in.) from the control end of the tub;
- unless the bathtub is freestanding, be equipped with a vertical grab bar conforming to 4.2.10 mounted on the wall

## Exhibit A

- which is at least 1220 mm (48 in.) long, mounted vertically at the foot end of the tub adjacent to the *clear floor space*, with the lower end 180 - 280 mm (7 – 11 in.) above the bathtub rim; and
- located within 150 mm (5-7/8 in.) from the edge of the tub.
- have controls equipped with a pressure-equalizing or thermostatic-mixing valve, operable from the seated position and in compliance with 4.4.2;
- have soap holder(s) which can be reached from the seated position, ideally fully recessed;
- have a slip resistant base; and
- have shower curtains, not sliding glass doors.

Enclosures for bathtubs shall not

- obstruct controls;
- interfere with a person transferring from a wheelchair; or
- have tracks mounted on the bathtub rim.

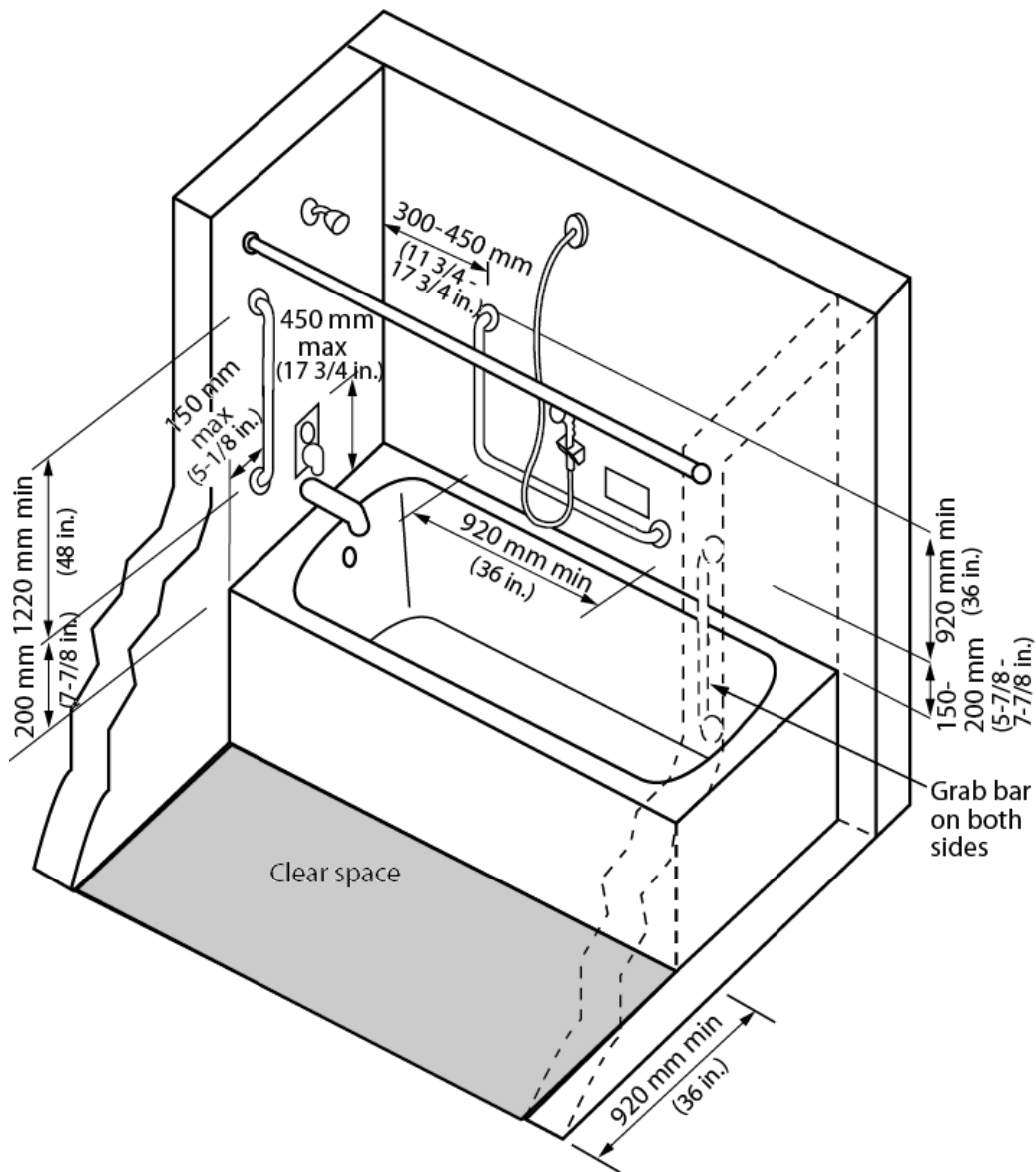


Figure 4.2.8.1 Bathtub

**RELATED SECTIONS**

- 4.1.1 Space and Reach Requirements
- 4.2.6 Washroom Accessories
- 4.2.10 Grab Bars
- 4.4.2 Controls and Operating Mechanisms
- 4.4.13 Lighting

## 4.4.16 Texture and Colour

**4.2.9 SHOWER STALLS****RATIONALE**

Roll-in or curbless shower stalls eliminate the hazard of stepping over a threshold and are essential for persons with *disabilities* who use wheelchairs or other mobility devices in the shower. Grab bars and non-slip materials are safety measures which will support any individual. Additional equipment such as a hand-held shower head or a folding bench, may be an asset to someone with a *disability* but also convenient for others. Equipment that *contrasts* in colour from the shower stall itself will assist individuals with a visual *impairment*.

**APPLICATION**

Where shower stalls are provided, all shower stalls shall comply with this section. In a retrofit situation where it is *technically infeasible* to have all shower stalls comply with this section, at least 10%, but never less than one, in each bathing *facility* shall comply with this section.

**DESIGN REQUIREMENTS**

*Accessible* shower stalls shall

- be on an *accessible route* complying with 4.1.4;
- be at least 1525 mm (60 in.) in width and 920 mm (36 in.) in depth;
- have a *clear floor space* at the *entrance* to the shower of at least 920 mm (36 in.) in depth and the same width as the shower, except that fixtures are permitted to project into that *space*, provided access to the shower is not restricted;
- have a slip-resistant floor surface, sloped no steeper than 1:100 (1%);
- have no threshold, or a beveled threshold not exceeding 13 mm (1/2 in.) above the finished floor;
- have a trench-style drain system across the entry to the shower that is *colour contrasted* to surrounding elements, or other measures to contain water within the shower area;
- be equipped with a wall-mounted hinged folding seat that is not spring-loaded, or make provisions for a water-resistant fixed seat that is
  - not less than 450 mm (17-3/4 in.) wide and 400 mm (15-3/4 in.) deep;
  - mounted not less than 430 mm (17 in.) and not more than 485 mm (19 in.) above the finished floor;
  - designed to carry a minimum load of 1.3 kN (300 lbs.); and
  - located so that the edge of the seat is within 500 mm (19-11/16 in.) of the shower controls;
- be equipped with a L-shaped grab bar that shall
  - conform to 4.2.10;
  - be located between the shower head and the controls;
  - have a horizontal component at least 920 mm (36 in.) long and a vertical component at least 760 mm (30 in.) long;

## Exhibit A

- be mounted so that the horizontal component is not more than 850 mm (33-1/2 in.) above the finished floor; and
- be mounted so that the end of the horizontal component is within 100 mm (3-15/16 in.) from the edge of the shower seat;
- be equipped with a vertical grab bar that shall
  - be at least 760 mm (30 in.) in length;
  - be mounted 80 - 120 mm (3-1/8 - 4-3/4 in.) from the front edge, starting between 700 and 800 mm (27-1/2 and 31-1/2 in.) from the floor; and
  - conform to 4.2.10;
- be equipped with a pressure-equalizing or thermostatic-mixing valve in compliance with 4.4.2, located above the grab bar but no higher than 1000 mm (39-3/8 in.), maximum 685 mm (27 in.) from the seat wall;
- have a fully recessed soap holder(s) that can be reached from the seated position; and
- be equipped with a shower head with at least 1500 mm (60 in.) of flexible hose that can be used both as a fixed position shower head and as a hand held shower head. The shower spray unit shall be reachable from the seated positions and have an on/off control.

EXCEPTION: The use of two fixed-height shower heads with the capability of adjusting the direction of water flow is permitted instead of a hand-held spray unit in *facilities* that may be subject to vandalism. The height of the higher shower head to be 1825 mm (72 in.). The height of the lower shower head to be 1400 mm (55-1/8 in.). A valve to direct water between the shower heads, in compliance with 4.4.2, shall be located adjacent to the shower control/ mixing valve.

Where the showerhead is mounted on a vertical bar, the bar shall be installed so as not to obstruct the use of the grab bar.

Enclosures for shower stalls shall not obstruct controls or obstruct transfer from a mobility device onto the shower seat.

**Table 4.2.9** Number of accessible showers

| # of showers | # of showers required to be <i>accessible</i> |
|--------------|---|
| 1 – 7        | 1   |
| More than 7  | 2 plus 1 for each increment of 7 showers      |



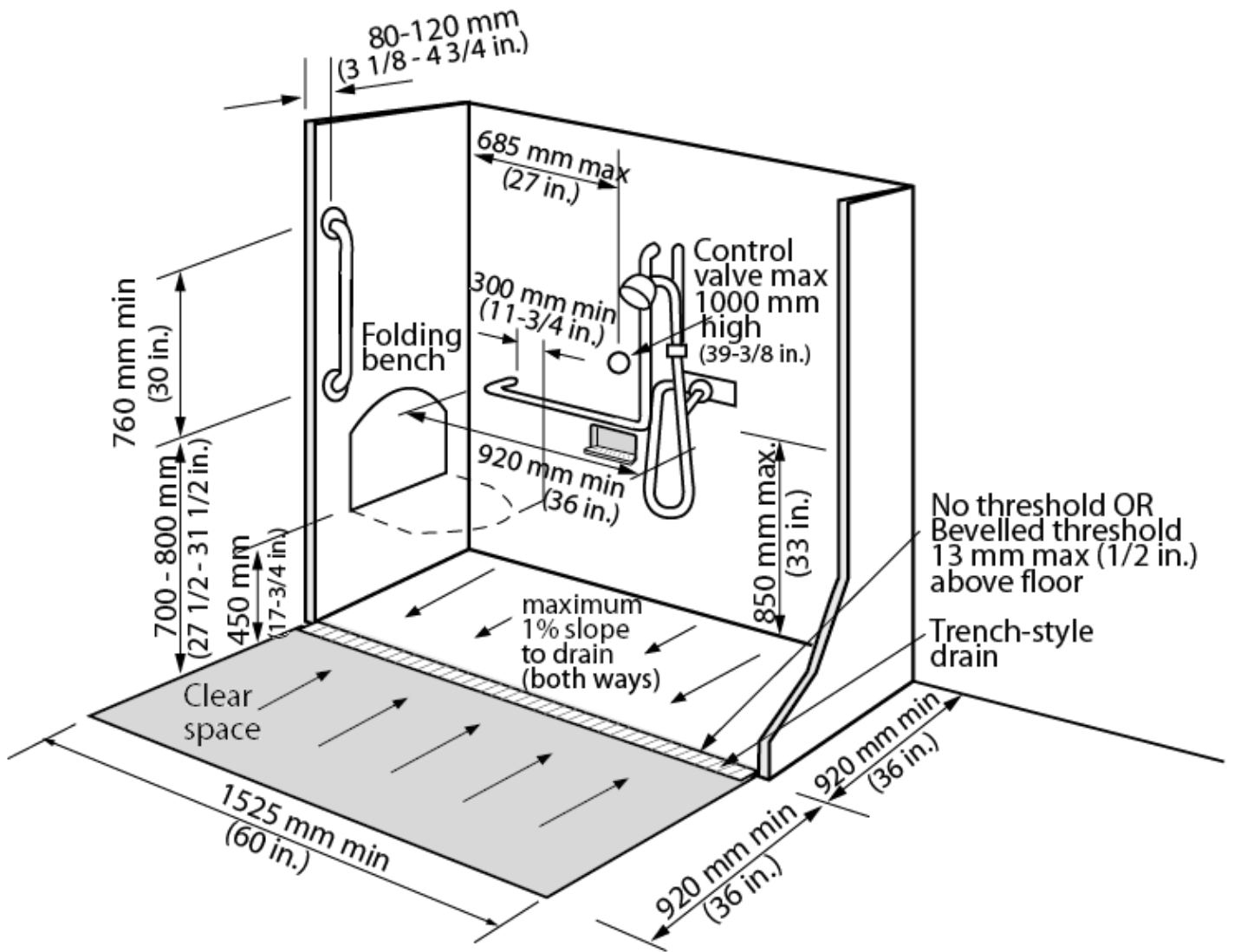
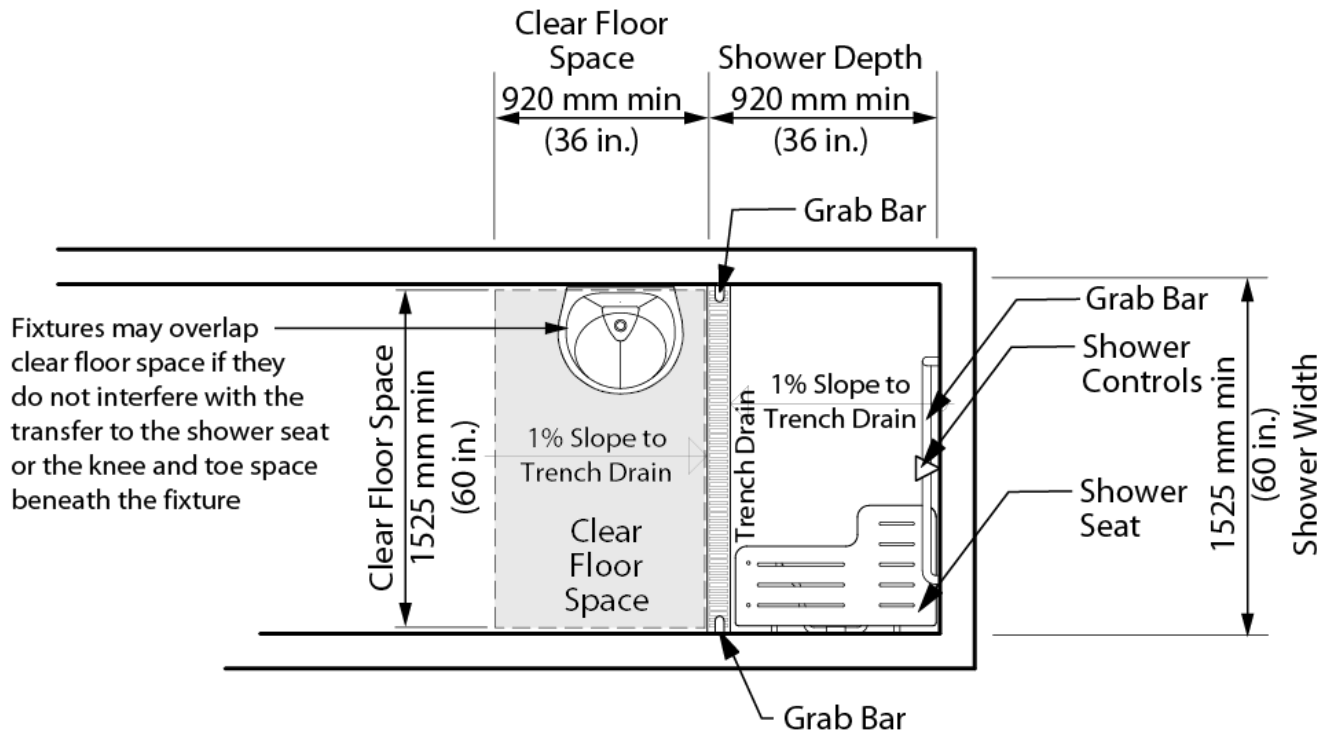


Figure 4.2.9.1 Shower Stall



**Figure 4.2.9.2** Plan View of Accessible Shower

## RELATED SECTIONS

- 4.1.1 Space and Reach Requirements
- 4.2.6 Washroom Accessories
- 4.2.10 Grab Bars
- 4.4.2 Controls and Operating Mechanisms
- 4.4.13 Lighting
- 4.4.15 Texture and Colour

## 4.2.10 GRAB BARS

### RATIONALE

Grab bars are an important feature to those who require assistance in standing up, sitting down or stability while standing. Transferring between toilet and wheelchair or scooter may be another scenario where grab bars are utilized.

### APPLICATION

Grab bars shall comply with this section.

## DESIGN REQUIREMENTS

Grab bars shall

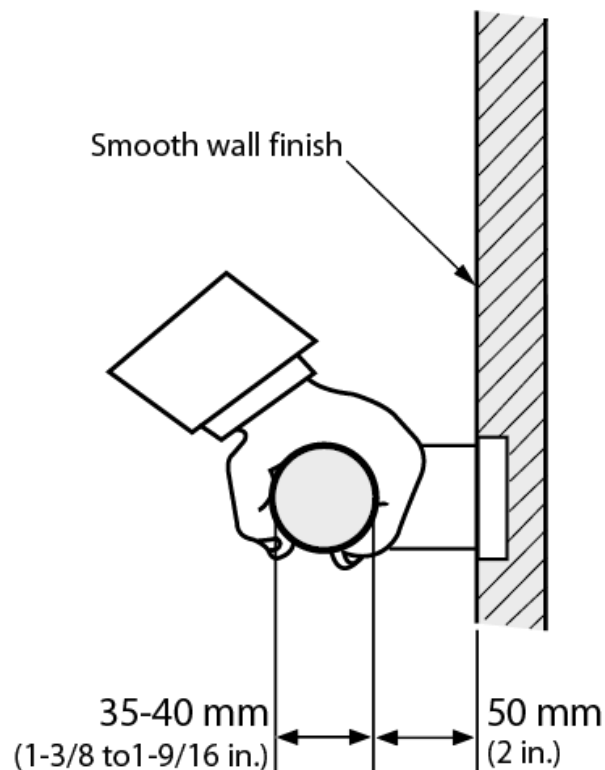
- be installed to resist a load of at least 1.3 kN (300 lb.), applied vertically or horizontally;
- be not less than 35 mm (1-3/8 in.) and not more than 40 mm (1-9/16 in.) in diameter;
- be free of any sharp or abrasive *elements*;
- be *colour contrasted* with the surrounding environment; and
- have a slip-resistant surface.

Wall-mounted grab bars shall have a clearance of not less than 38 mm (1-1/2 in.) and not more than 50 mm (2 in.) to the wall.

Drop-down grab bars shall comply with 4.2.3.

Adjacent surfaces shall be free of any sharp or abrasive *elements*.

The type of grab bar installation should depend on the expected user population of the *facility*. In retirement and long-term care settings with a senior's population, the angled grab bar is preferable because it allows easy maneuvering on and off a toilet seat. In public water closet stalls and special washrooms, the L-shaped grab bar is preferable, because the horizontal bar allows lateral transfer to the toilet seat from a wheelchair, and the vertical bar meets a variety of other user needs. Swing away grab bars, floor or wall mounted, are acceptable, provided installation complies with this section.



**Figure 4.2.10.1** Grab Bar

## RELATED SECTIONS

4.1.1 Space and Reach Requirements

4.2.3 Toilets

4.2.5 Urinals

4.2.7 Universal Washrooms

4.2.8 Bathtubs

4.2.9 Shower Stalls

4.4.13 Lighting

4.4.15 Texture and Colour

## 4.3 OTHER AMMENITIES

### 4.3.1 DRINKING FOUNTAINS

#### RATIONALE

When planning the design of drinking fountains, one should consider the limited height of children and that of a person using a wheelchair or scooter. In the same respect, there may be individuals who have difficulty bending who would require a higher fountain. The operating system should account for limited hand strength or dexterity. The placement of the fountain is also important. Fountains should be recessed, to avoid protruding into the *path of travel*, especially if they are wall mounted above the detectable height of a person using a cane. Angled recessed alcove designs allow more flexibility and less precision required by a person using a wheelchair or scooter.

#### APPLICATION

Where drinking fountains are provided on a floor level, at least one shall be *accessible* and shall comply with this section. Where more than one drinking fountain or water cooler is provided on a floor level, at least 50% shall be *accessible* and shall comply with this section.

Where only one drinking fountain is provided on a floor level, it shall incorporate components that are *accessible* to individuals who use mobility devices and to those who have difficulty stooping or bending.

#### DESIGN REQUIREMENTS

*Accessible* drinking fountains shall

- be located on an *accessible route* complying with 4.1.4;
- have a spout located near the front of the unit between 760 mm (30 in.) and 900 mm (35-1/2 in.) above the floor or ground surface;

## Exhibit A

- be equipped with controls that are located on the front of the unit, or on both sides of the unit, easily operated from a wheelchair or scooter using a closed fist with a force of not more than 22.2 N (4.9 lb.), or be automatically operable;
- be detectible by a cane at a level at or below 680 mm (26-3/4 in.) from the finished floor; and
- have a spout that provides a water stream
  - at least 100 mm (3-15/16 in.) high, and
  - at a vertical angle of up to
    - 30 degrees, where the spout is located less than 75 mm (2-15/16 in.) from the front of the fountain, or
    - 15 degrees, where the spout is located not less than 75 mm (2-15/16 in.) and not more than 125 mm (5-7/8 in.) from the front of the fountain.

Cantilevered drinking fountains shall

- have a *clear floor space* of at least 810 mm (32 in.) by 1370 mm (54 in.);
- have a knee *space* between the bottom of the unit and the floor of at least 810 mm (32 in.) wide, 500 mm (19-1/2 in.) deep and 735 mm (29 in.) high;
- have a toe clearance height of at least 350 mm (13-3/4 in.) above finished floor, from a point 300 mm (11-3/4 in.) back from the front edge to the wall;
- have a depth at the base of the fountain of at least 700 mm (27-1/2 in.); and
- be recessed with the face level with the adjoining walls or otherwise located out of the circulation route.

Freestanding or built-in fountains not having a knee *space* shall have a *clear floor space* at least 1370 mm (54 in.) wide by 810 mm (32 in.) deep in front of the unit to accommodate a parallel approach.

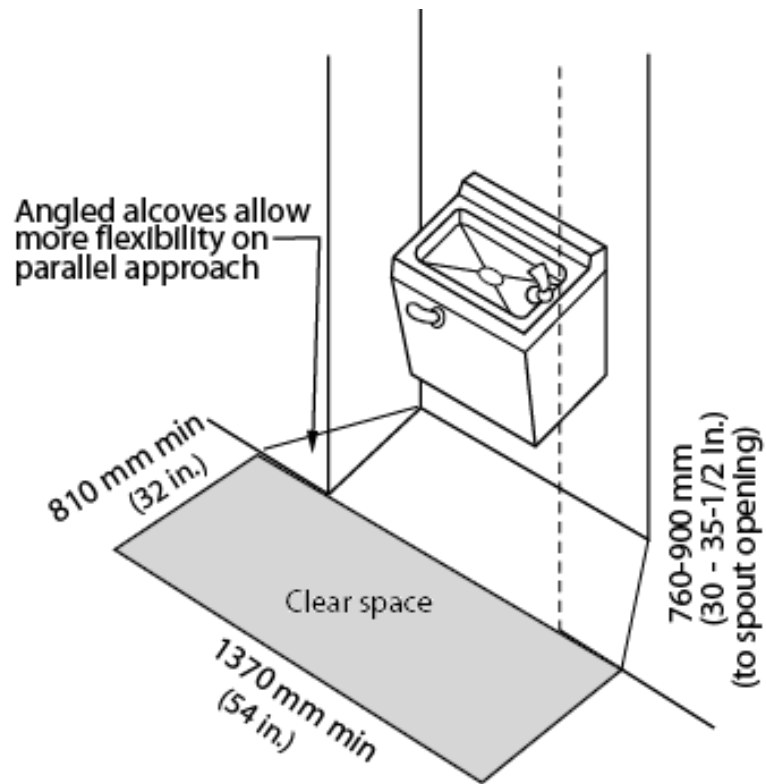


Figure 4.3.1.1 Parallel Approach

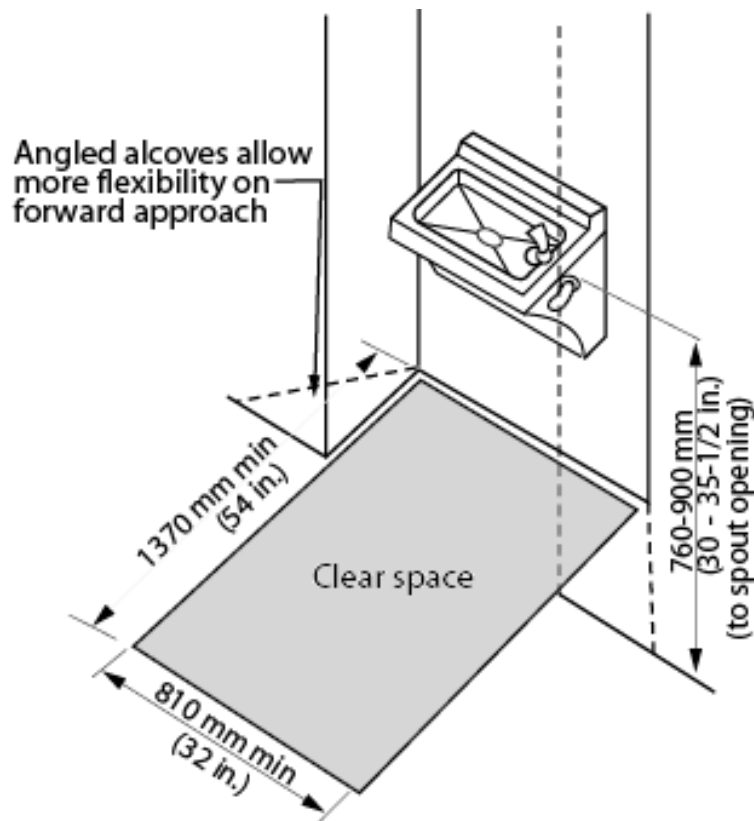
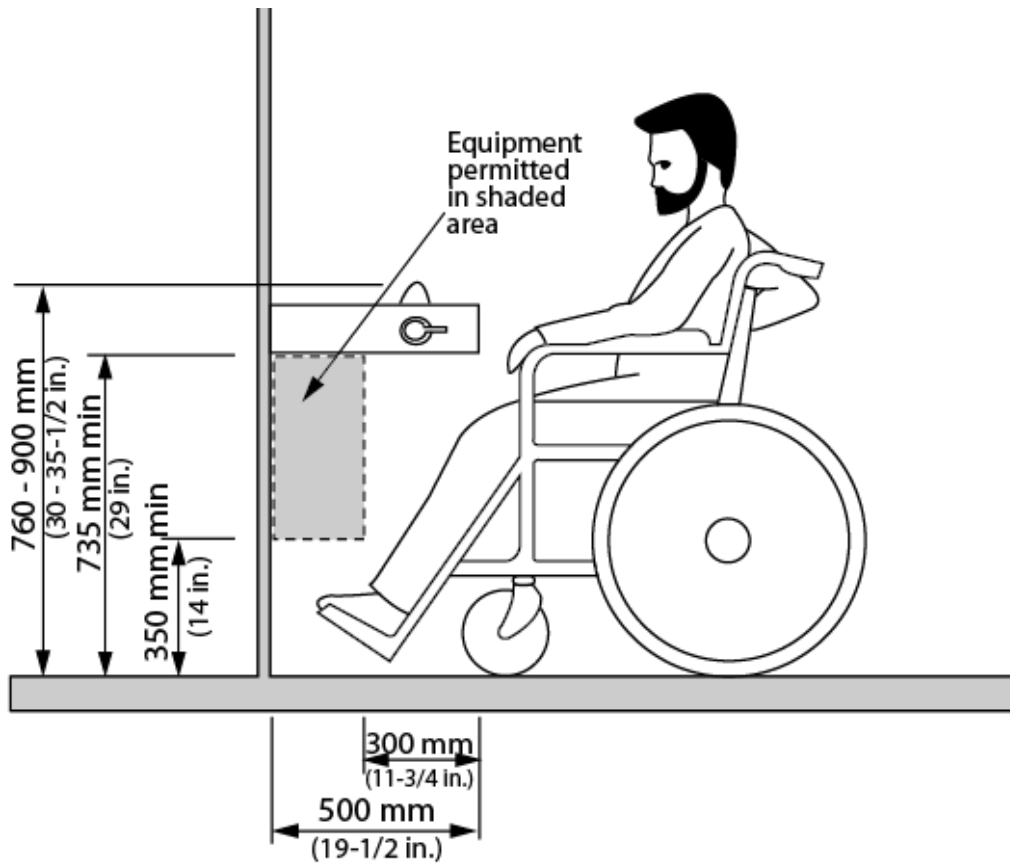


Figure 4.3.1.2 Front Approach



**Figure 4.3.1.3** Clearances

## RELATED SECTIONS

- 4.1.1 Space and Reach Requirements
- 4.1.2 Ground and Floor Surfaces
- 4.1.3 Protruding and Overhead Objects
- 4.1.4 Accessible Routes, Paths and Corridors
- 4.4.13 Lighting
- 4.4.14 Materials and Finishes
- 4.4.15 Texture and Colour

## 4.3.2 VIEWING POSITIONS

### RATIONALE

Designated viewing areas are required for individuals unable to use typical seating. Viewing areas need to provide adequate *space* to maneuver a mobility device as large as a scooter and should not be limited to one location. Designated companion seating should also be provided. Guards placed

around a viewing area should not interfere with the line of sight of someone sitting in a wheelchair or scooter. A choice of locations and ticket price range should be available.

Providing only one size of seating does not reflect the diversity of body types of our society. Seating with increased legroom will better suit individuals that are taller. Seats with removable armrests (*adaptable seating*) are helpful for persons of larger stature as well as individuals using wheelchairs that prefer to transfer to the seat.

**APPLICATION**

In places of assembly occupancy with fixed seating, *accessible* wheelchair/scooter locations shall comply with this section and shall be provided in numbers as indicated by Table 4.3.2.

Adaptable seats shall be provided in compliance with Table 4.3.2.

Spaces for the storage of wheelchairs and other *mobility assistive devices* shall be provided to accommodate the users of the adaptable seats in compliance with Table 4.3.2.

*Accessible* wheelchair/scooter locations shall be an integral part of any seating plan. Seats shall be distributed in a manner that provides people with physical disabilities a choice of admission prices and lines of sight comparable to those for members of the general public.

| <b>Table 4.3.2 Wheelchair viewing locations</b> |  |  |   |
|---|--|--|---|
| <b>Number of Fixed Seats in Seating Area</b>    | <b>Minimum number of Spaces Required for Wheelchairs</b> | <b>Minimum number of Adaptable Seats</b> | <b>Minimum number of Storage Facilities for Wheelchairs</b> |
| Up to 40  | 2  | 2  | 2   |
| 41 - 80   | 3  | 4  | 2   |
| 81 - 100  | 4  | 5  | 2   |
| 101 - 150                                       | 5  | 5% of all aisle seating                  | 2 + 2 for every additional 100 seats                        |
| 151 - 200                                       | 6  | 5% of all aisle seating                  | 2 + 2 for every additional 100 seats                        |
| 201 - 300                                       | 9  | 5% of all aisle seating                  | 2 + 2 for every additional 100 seats                        |
| 301 - 400                                       | 12   | 5% of all aisle seating                  | 2 + 2 for every additional 100 seats                        |
| 401 - 600                                       | 15   | 5% of all aisle seating                  | 2 + 2 for every additional 100 seats                        |
| Over 600  | Not less than 3% of the seating capacity                 | 5% of all aisle seating                  | 2 + 2 for every additional 100 seats                        |

**DESIGN REQUIREMENTS**

*Accessible* wheelchair/scooter locations shall adjoin an *accessible route* complying with 4.1.4, without infringing on *egress* from any row of seating or any aisle requirement.

Each *accessible* wheelchair/scooter location shall be



- *clear* and level, or level with removable seats;
- if the wheelchair/scooter enters from a side approach, not less than 920 mm (36 in.) wide and 1525 mm (60 in.) long;
- if the wheelchair/scooter enters from a front or rear approach, not less than 920 mm (36 in.) wide and 1370 (54 in.) long;
- arranged so that at least two designated wheelchair/scooter locations are side by side;
- arranged so that at least one companion fixed seat is provided next to each wheelchair seating area (Note: Companion seating to be calculated in addition to the required *accessible* seating spaces identified in Table 4.3.2);
  - each group of designated spaces, if 2 or more designated spaces are arranged side by side in a group; and
  - each designated space that is not part of a group;
- where the seating capacity exceeds 100, provided in more than one location;
- located so as not to obstruct the view of persons who may be seated behind;
- providing lines of sight that are comparable to those for all viewing positions, and that will not be reduced or obstructed by standing members of the audience;
- free of guardrails interfering with lines of sight; and
- located without infringing on egress from any row of seating or aisle.

Every place of assembly intended for the viewing of motion pictures or the performing arts, shall be equipped to provide an average level of illumination at floor level in the aisles of not less than 2 lux during the viewing.

Fixed seats designated for *adaptable seating* shall be

- located without infringing on egress from any row of seating or aisle;
- equipped with moveable or removable arm rest on the side of the seat adjoining the barrier-free *path of travel*; and
- situated as part of the designated seating plan to provide choice of viewing location and clear view of the event taking place.

Storage facilities for wheelchairs and other *mobility assistive devices* shall

- have a minimum floor space of 810 mm (32 in.) by 1370 mm (54 in.) for each device; and
- be located on the same level and as close as practicable to the designated seating spaces.

Every place of assembly intended for the viewing of motion pictures or the performing arts shall be equipped to provide an average level of illumination at floor level in the aisles of not less than 2 lux during the viewing.

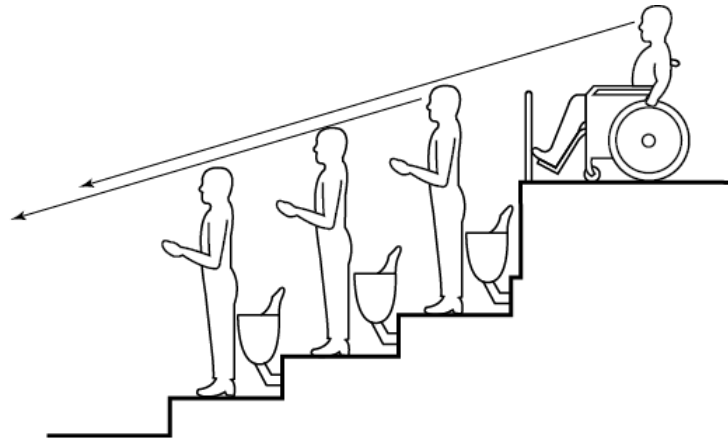


Figure 4.3.2.1 Sight Lines at Wheelchair Locations

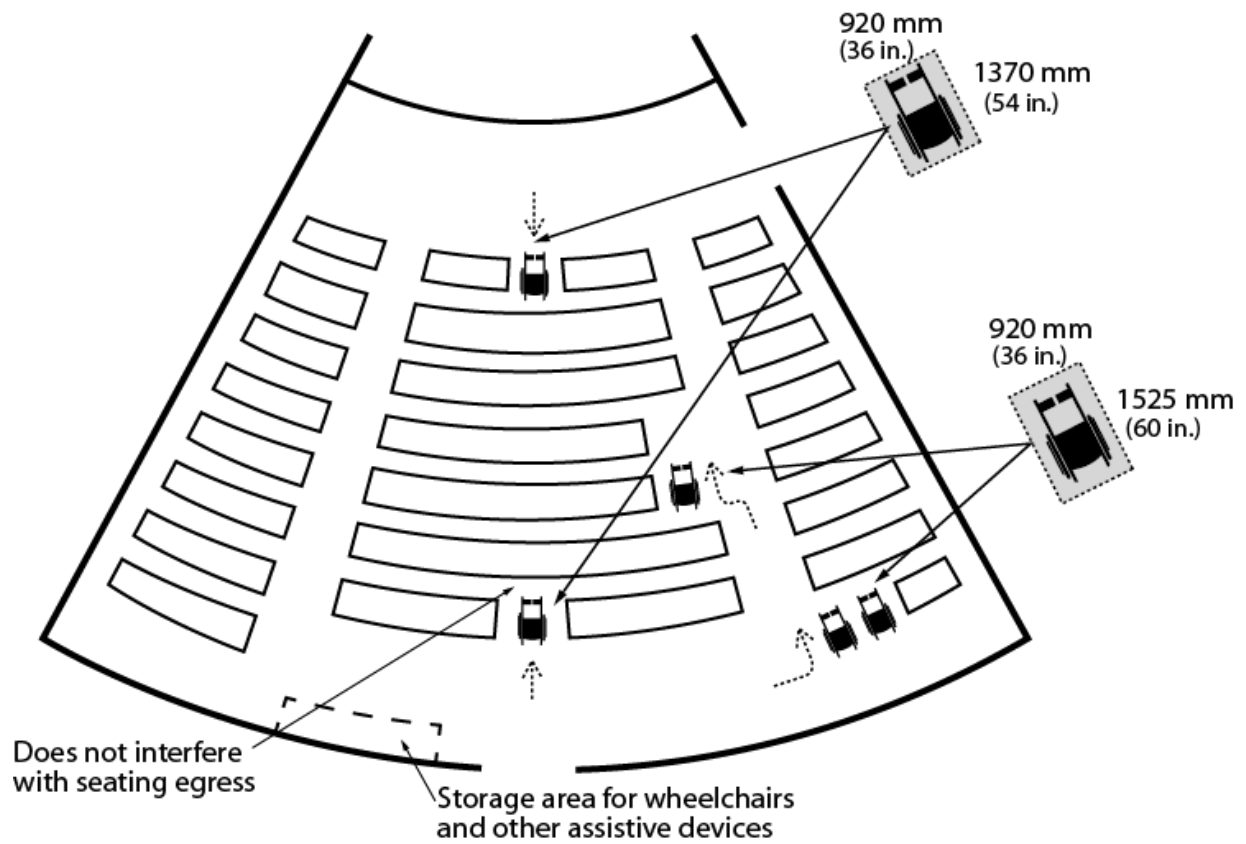


Figure 4.3.2.2 Distribution of Wheelchair Locations

**RELATED SECTIONS**

4.1.1 Space and Reach Requirements

4.1.2 Ground and Floor Surfaces

4.1.3 Protruding and Overhead Objects

4.1.4 Accessible Routes, Paths and Corridors

4.4.6 Assistive Listening Systems

4.4.7 Signage

4.4.9 Public Address System

4.4.14 Materials and Finishes

4.4.15 Texture and Colour

4.4.16 Acoustics

### 4.3.3 ELEVATED PLATFORMS

#### RATIONALE

Elevated platforms, such as stage areas, speaker podiums, etc., should be *accessible* to all. A marked *accessible route* should be provided, along with safety features to assist persons who are visually impaired.

#### APPLICATION

Elevated platforms provided for use by the general public, clients, customers or employees shall comply with this section.

#### DESIGN REQUIREMENTS

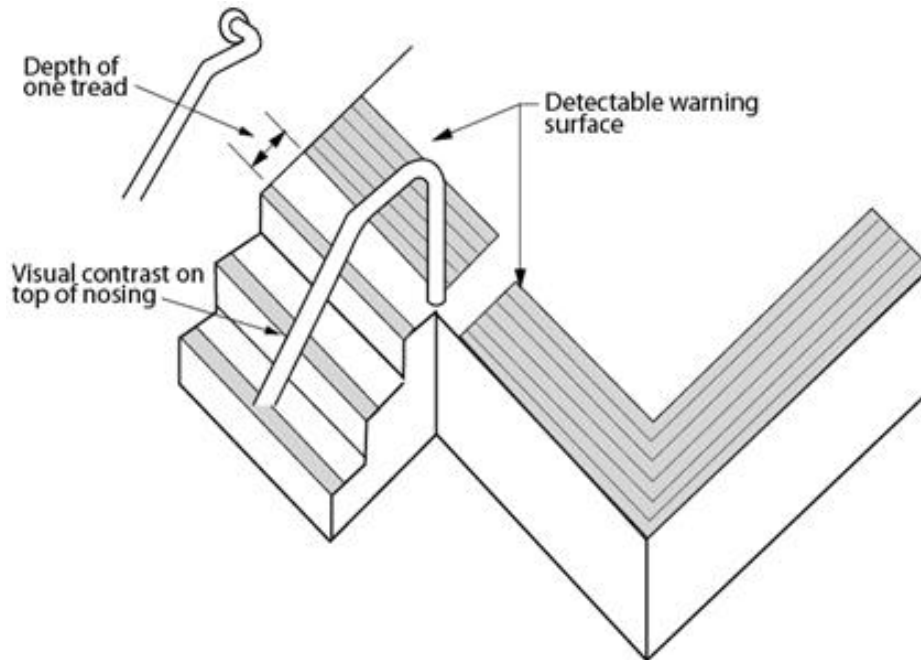
Elevated platforms shall

- be located on an *accessible route* that complies with 4.1.4;
- be capable of being illuminated to at least 100 lux (9.3 ft.-candles) at floor level at the darkest point;
- be sized to safely accommodate wheelchairs and other mobility equipment in compliance with 4.1.1; and
- have open platform edges defined by a *detectable warning surface* along any edge of a platform that is not protected by a guard, and higher than 250 mm (9-13/16 in.) above the finished floor or ground or sloped steeper than 1 in 3 (33.3%).

A ramp shall be provided for stages in compliance with section 4.1.9.

The *detectable warning surface* on elevated platforms shall

- comply with the requirements of 4.4.8;
- consist of flat-topped domes or cones in compliance with the requirements of 4.4.8;
- be consistent throughout the setting;
- be positioned parallel to the open platform edge, extending the full length of the platform; and
- be a minimum depth of 300 mm (11-13/16 in.) and a maximum of 610 mm (24 in.), flush from the open edge of the platform.



**Figure 4.3.3.1** Detectable Warning Surfaces at Elevated Platform

**RELATED SECTIONS**

- 4.1.1 Space and Reach Requirements
- 4.1.2 Ground and Floor Surfaces
- 4.1.3 Protruding and Overhead Objects
- 4.1.4 Accessible Routes, Paths and Corridors
- 4.1.9 Ramps
- 4.4.8 Detectable Warning Surfaces
- 4.4.13 Lighting
- 4.4.14 Materials and Finishes
- 4.4.15 Texture and Colour

## 4.3.4 DRESSING ROOMS

### RATIONALE

In addition to *accessible common use* dressing rooms, a separate unisex dressing room is useful. This is valuable in a scenario where an attendant of the opposite sex or a parent is assisting a child. Sufficient *space* should be allowed for two people and a wheelchair, along with benches and accessories.

The provision of *handrails* along circulation routes from dressing rooms to pool, gymnasium and other activity areas, will be of benefit to many *facility* users.

### APPLICATION

Where dressing rooms are provided for use by the general public, patients, performers, customers or employees, they shall comply with this section. In a retrofit situation where it is *technically infeasible* to have all dressing rooms comply with this section, 10% of dressing rooms, but never less than one, for each type of use in each cluster of dressing rooms shall be *accessible* and comply with this section.

At least one private *accessible* dressing room shall be provided within *accessible* change rooms at pools, gymnasiums, and other *accessible* facilities

### DESIGN REQUIREMENTS

*Accessible* dressing rooms and accessible elements within accessible dressing rooms, shall be located on an *accessible route* complying with 4.1.4.

*Accessible* dressing rooms shall be labeled with the Dynamic Symbol of Access.

Private *accessible* dressing rooms shall incorporate a *clear floor space* allowing a person using a wheelchair or scooter to make a 180-degree turn, accessed through either a hinged or sliding door. No door shall swing into any part of the required turning *space* within the private *accessible* dressing room. Turning *space* is not required within a private *accessible* dressing room accessed through a curtained opening of at least 950 mm (37-1/2 in.) wide, if *clear floor space* complying with section 4.1.1 renders the dressing room usable by a person in a wheelchair or scooter.

All doors to *accessible* dressing rooms shall be in compliance with 4.1.6. Outward swinging doors shall not constitute a hazard to persons using adjacent circulation routes.

Every *accessible* dressing room shall have an 810 mm (31-7/8 in.) x 1830 mm (72 in.) bench fixed to the wall along the longer dimension. The bench shall

- be mounted 450 to 500 mm (17-3/4 in. to 19-5/8 in.) above the finished floor;
- have *clear floor space* at least 760 mm (30 in.) wide provided alongside the bench to allow a person using a wheelchair or scooter to make a parallel transfer onto the bench; and
- be designed to carry a minimum load of 1.33 kN (300 lb.).

Where coat hooks are provided, they shall be a collapsible-style projecting not more than 50 mm (2 in.) from the wall. At least two collapsible coat hooks shall be mounted no higher than 1200 mm (47

## Exhibit A

in.) above the floor, and immediately adjacent to the *accessible* bench. (Note: Coat hooks should not be located over the *accessible* bench or in areas that may cause a hazard.)

To enable transfer to the bench, grab bars similar to those in section 4.2.9 Showers shall be provided in a suitable location in the dressing room.

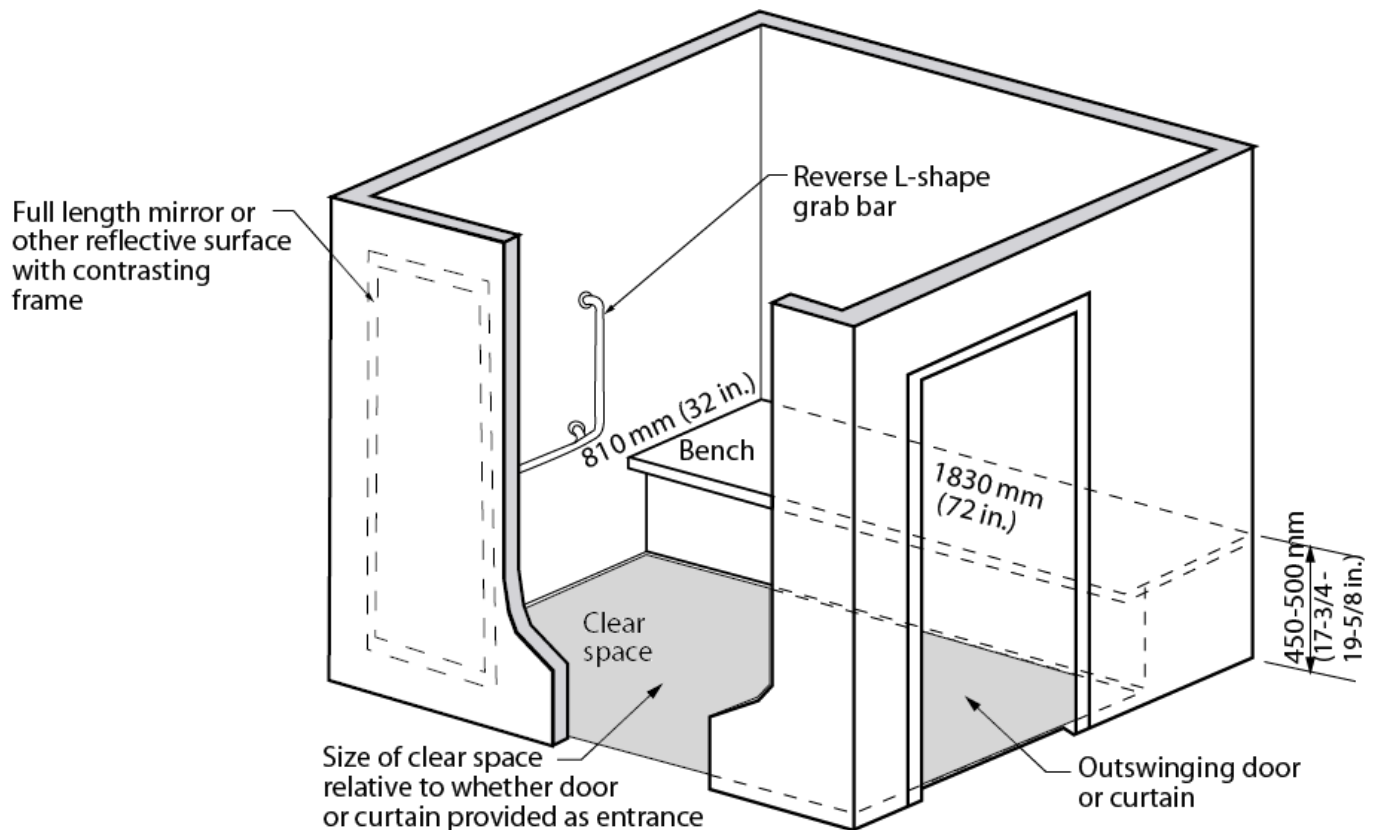
Where dressing rooms are provided in conjunction with showers, swimming pools, or other wet locations, they shall

- be designed with a slip-resistant floor surface that prevents the accumulation of standing water; and
- have a bench with a slip-resistant seat surface installed to prevent the accumulation of water.

Where mirrors, or other reflective surfaces, are provided in dressing rooms of the same use, *accessible* dressing rooms shall incorporate a full-length mirror or other reflective surface measuring at least 460 mm (18 in.) wide by 1370 mm (54 in.) high and shall be mounted in a position affording a view to a person on the bench, as well as to a person in a standing position.

Dressing rooms shall incorporate even illumination throughout of at least 200 lux (20 ft.-candles).

For open area large group change areas (such as locker rooms) refer to section 4.3.10.



**Figure 4.3.4.1** Private Accessible Dressing Room

## RELATED SECTIONS

### 4.1.1 Space and Reach Requirements

4.1.2 Ground and Floor Surfaces

4.1.3 Protruding and Overhead Objects

4.1.4 Accessible Routes, Paths and Corridors

4.4.13 Lighting

4.4.14 Materials and Finishes

4.4.15 Texture and Colour

## 4.3.5 OFFICES, WORK AREAS & MEETING ROOMS

### RATIONALE

Offices providing services or programs to the public should be *accessible* to all, regardless of mobility or functional profile. Furthermore, office and related support areas should be *accessible* to staff and visitors with varying levels of ability.

All persons, but particularly those with a hearing *impairment*, would benefit from having a quiet acoustic environment - background noise from mechanical equipment such as fans, should be minimal. Telephone equipment for individuals with hearing *impairments* may also be required.

The provision of assistive speaking devices is important for the range of individuals who may have difficulty with low vocal volume thus affecting production of normal audible levels of sound.

Tables and workstations should address the knee *space* requirements of an individual in a wheelchair. Circulation areas also need to consider the spatial needs of mobility equipment as large as scooters.

Natural coloured task lighting, such as that provided through halogen bulbs, is a design feature that will facilitate use by all, especially persons with vision *impairments*. In locations where reflective glare may be problematic, such as large expanses of glass with reflective flooring, consideration should be given to providing blinds that can be louvered upwards.

### APPLICATION

Wherever offices, work areas or *meeting rooms* are provided for use by the general public, employees, clients or customers, they shall comply with this section.

While all new office accommodations are required to comply with this standard, only relevant alterations will require existing facilities to be up-graded.

### DESIGN REQUIREMENTS

Where offices, work areas and *meeting rooms* are provided for use by the general public, employees, clients or customers, they shall

- where equipped with a door, the door shall comply with 4.1.6;

- be located on an accessible route complying with 4.1.4;
- incorporate a *clear floor space* allowing a person using a wheelchair or scooter to make a 180-degree turn;
- incorporate an *accessible route* throughout the *space* that does not require a person using a wheelchair or scooter to travel backwards to enter/leave the *space*;
- incorporate an *accessible route* that connects the primary activity *elements* within the office, work area or meeting room;
- incorporate knee clearances below work surfaces that comply with 4.3.7;
- incorporate access to storage, shelving or display units in compliance with 4.3.9 for use by the general public, employees, clients or customers;
- provide a *clear floor space* that complies with 4.1.1 in front of all equipment such as photocopiers where such equipment is provided for use by the general public, employees, clients or customers;
- be equipped with an assistive listening system that complies with 4.4.6, where an assistive listening system is required; and
- provide one of the following: gooseneck fixed microphone at designated seating area, cordless microphone or a personal voice amplification system.

All common areas, corridors, meeting rooms, and office spaces with fixed walls, shall comply with the space requirements listed in this document.

Where office spaces are designed in an open concept setting, with adjustable walls and furniture, not all spaces will be required to be as large as noted above. However, open concept office spaces should be able to be reconfigured on an as-needed basis to conform to the standards of this document.

### RELATED SECTIONS

4.1.1 Space and Reach Requirements

4.1.2 Ground and Floor Surfaces

4.1.4 Accessible Routes, Paths and Corridors

4.1.8 Windows, Glazed Screens and Sidelights

4.3.7 Tables, Counters and Work Surfaces

4.3.9 Storage, Shelving and Display Units

4.4.2 Controls and Operating Mechanisms

4.4.4 Visual Alarms

4.4.6 Assistive Listening Systems

4.4.12 Glare and Light Sources

4.4.13 Lighting



4.4.14 Materials and Finishes

4.4.15 Texture and Colour

4.4.16 Acoustics

### 4.3.6 WAITING AND QUEUING AREAS

#### RATIONALE

Queuing areas for information, tickets or services should permit persons who use wheelchairs, scooters and other mobility devices as well as persons with a varying range of user ability to move through the line safely and conveniently.

Waiting and queuing areas need to provide *space* for mobility devices, such as wheelchairs and scooters.

Queuing lines that turn corners or double back on themselves will need to provide adequate *space* to maneuver mobility devices. Providing *handrails* in queuing lines may be useful support for individuals and guidance for those with a visual *impairment*. The provision of benches in waiting areas is important for individuals who may have difficulty with standing for extended periods.

#### APPLICATION

In addition to the design requirements specified in 4.1 to 4.4, waiting and queuing areas shall comply with this section.

#### DESIGN REQUIREMENTS

Barriers at queuing areas shall be laid out in parallel, logical lines, spaced a minimum of 1100 mm (43 1/4 in.) apart. The accessible *path of travel* between fixed queuing lines and barriers shall comply with 4.1.4.

Barriers at queuing areas, provided to streamline pedestrian movement, shall be firmly mounted to the floor, and should have rigid rails to provide support for waiting persons.

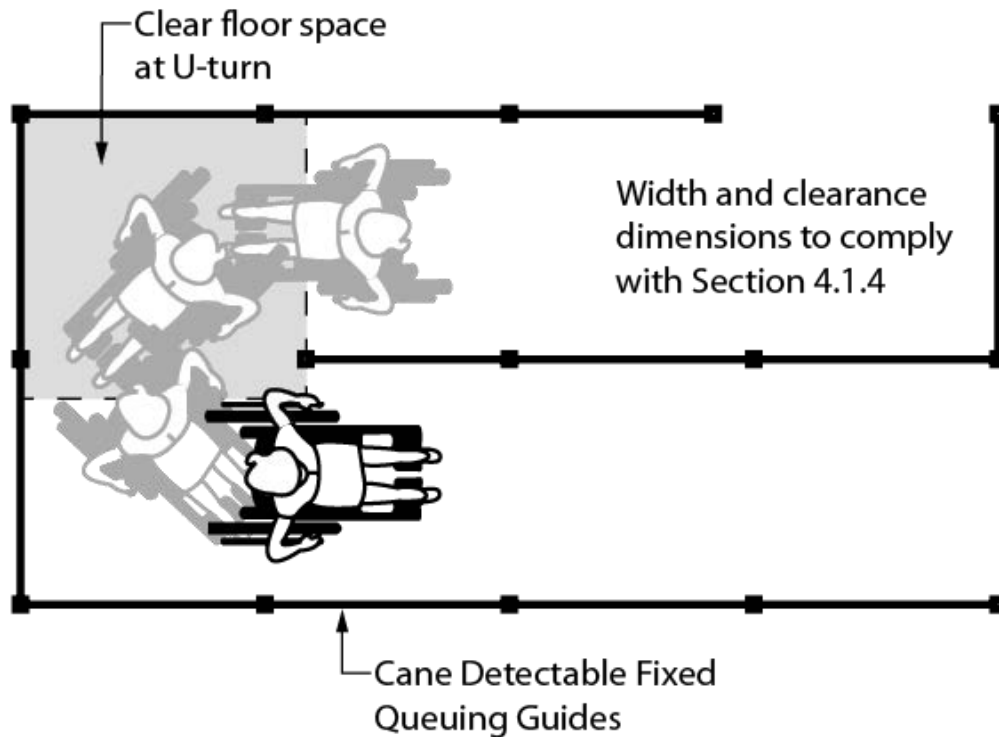
Where floor slots or pockets are included to receive temporary or occasional supports, such slots or pockets shall be level with the floor finish and have an integral cover, so as not to cause a tripping hazard.

Permanent queuing areas shall incorporate clearly defined floor patterns/colours/textures in compliance with 4.4.15, as an aid to guide persons with a visual *impairment*. There shall be a pronounced *colour contrast* between ropes, bars or solid barriers used to define queuing areas and the surrounding environment. Provide sufficiently clear floor area to permit mobility aids to turn where queuing lines change direction (refer to figures 4.1.4.3 and 4.1.4.4).

Fixed queuing guides must be cane detectable.

In waiting rooms where seating is fixed to the floor, a minimum of 3% but no less than 1 seat of the total seating must provide the clear floor space for mobility devices as defined in section 4.3.2.

Accessible seating shall have an adjacent companion seat.



**Figure 4.3.6.1** Fixed Queuing Guides

**RELATED SECTIONS**

- 4.1.1 Space and Reach Requirements
- 4.1.2 Ground and Floor Surfaces
- 4.1.4 Accessible Routes, Paths and Corridors
- 4.4.5 Public Telephones
- 4.4.6 Assistive Listening Systems
- 4.4.7 Signage
- 4.4.9 Public Address Systems
- 4.4.10 Information Systems
- 4.4.12 Glare and Light Sources
- 4.4.13 Lighting

4.4.14 Materials and Finishes

4.4.15 Texture and Colour

4.4.16 Acoustics

### 4.3.7 TABLES, COUNTERS AND WORK SURFACES

#### RATIONALE

Tables, counters and work surfaces should accommodate the needs of a range of users. Consideration should be given to standing-use as well as seated use. For individuals using wheelchairs, tables need to be high enough to provide knee *space* and provide enough *clear space* for the wheelchair to pull into. The furniture placement at tables and maneuvering space at counters should provide sufficient turning *space* for a person using a wheelchair or scooter.

Tables that have the support leg(s) in the centre of the table provide a higher level of accessibility.

#### APPLICATION

If fixed or built-in tables, counters and work surfaces (including, but not limited to, dining tables and study carrels) are provided in *accessible* public or *common use* areas, at least 10%, but not less than one, of the fixed or built-in tables, counters and work surfaces shall comply with this section.

It is preferred to locate counters out of the circulation route so they do not become an obstacle for persons who use canes and or persons with vision loss/no vision.

Ensure that chairs with armrests are provided for banquet halls, restaurants and cafeterias.

#### DESIGN REQUIREMENTS

*Accessible* tables, counters and work surfaces shall be located on an *accessible route* complying with 4.1.4.

An *accessible route* complying with 4.1.4 shall lead to and around such fixed or built-in tables, counters and work surfaces.

Wheelchair seating *spaces* at *accessible* tables, counters and work surfaces shall incorporate a *clear floor space* of not less than 810 mm (32 in.) by 1370 mm (54 in.). It may overlap the clear floor space by a maximum of 480 mm (18-7/8 in.).

Where a forward approach is used to access a wheelchair seating *space*,

- a *clear knee space* of at least 810 mm (32 in.) wide, 480 mm (18-7/8 in.) deep and 685 mm (27 in.) high shall be provided; and
- a clear toe space at least 810 mm (32 in.) wide and 230 mm (18-7/8 in.) high shall be provided beyond the knee space, extending to a depth at least 610 mm (24 in.) from the front edge of the work surface.

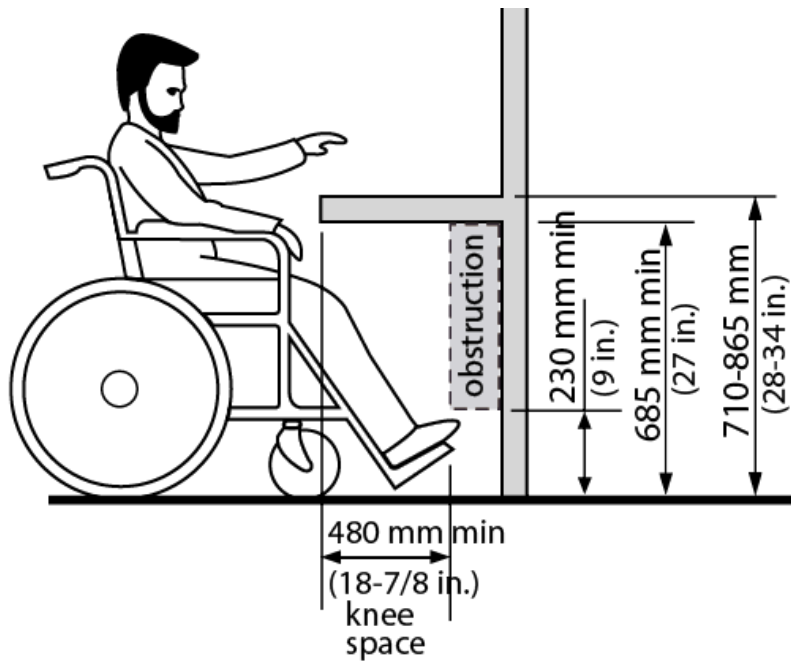


Figure 4.3.7.1 Clearances

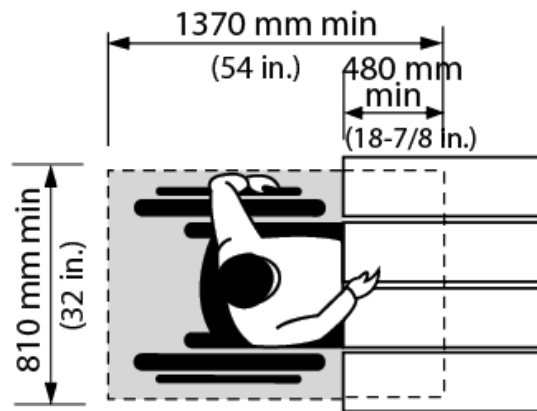
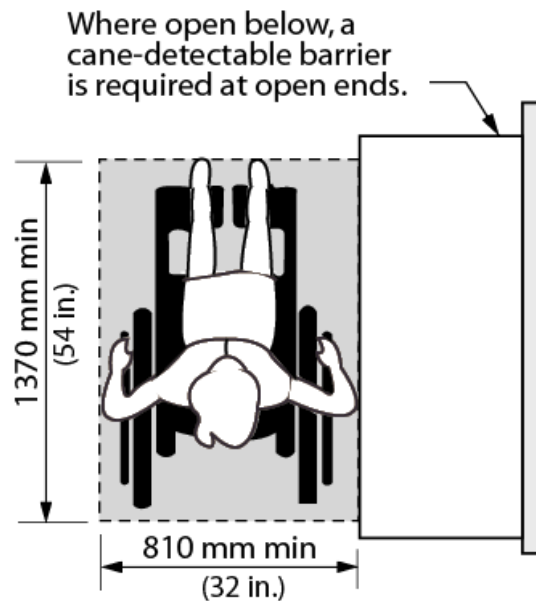


Figure 4.3.7.2 Frontal Approach



**Figure 4.3.7.3 Parallel Approach**

The top of *accessible* tables, counters and work surfaces shall be located between 710 mm (28 in.) to 865 mm (34 in.) above the finished floor or ground surface. It is preferred to provide height-adjustable furnishings.

Where speaker podiums are provided they shall

- be located on an accessible route in compliance with 4.1.4;
- be height-adjustable for use from a seated or standing position;
- incorporate controls and operating mechanisms in compliance with 4.4.2;
- incorporate clear knee space of at least 810 mm (32 in.) wide, 480 mm (18-7/8 in.) deep and 685 mm (27 in.) high; and
- incorporate clear floor space of at least 810 mm (32 in.) by 1370 mm (54 in.), configured for forward approach.

## RELATED SECTIONS

4.1.1 Space and Reach Requirements

4.1.3 Protruding & Overhead Object

4.1.4 Accessible Routes, Paths and Corridors

### 4.3.8 INFORMATION, RECEPTION AND SERVICE COUNTERS

#### RATIONALE

Information, reception and service counters should be *accessible* to the full range of visitors. A choice of counter heights is recommended to provide a range of options for a variety of persons. Lowered sections will serve children, persons of short stature and persons using mobility devices such as a wheelchair or scooter. The choice of heights should also extend to speaking ports and writing surfaces.

The provision of knee space under the counter facilitates use by a person using a wheelchair or a scooter.

The provision of *assistive speaking devices* is important for the range of individuals who may have difficulty with low vocal volume thus affecting production of normal audible levels of sound.

The use of *colour contrast*, tactile difference or audio landmarks (e.g., receptionist voice or music source) can assist individuals with a visual *impairment* to more precisely locate service counters or speaking ports.

#### APPLICATION

Counters for information or service shall have at least one section *accessible* to persons who use a wheelchair or scooter.

For each type of service provided, at least 1 accessible service counter shall be provided.

Where there are multiple queuing lines serving multiple service counters, the accessible service counters must be clearly identified by signage.

#### DESIGN REQUIREMENTS

Information, reception and service counters shall be located on an *accessible route* complying with 4.1.4.

Counters for information, reception or service shall incorporate at least one *accessible* section that

- has a counter height located between 710 mm (28 in.) and 865 mm (34 in.) above the finished floor or ground;
- has a counter surface width of at least 920 mm (36 in.);
- has a counter depth of no more than 1270 mm (50 in.) that complies with 4.1.1; and
- has knee *space* on both sides of the counter, below the counter surface, of at least 685 mm (27 in.) high by 480 mm (18-7/8 in.) deep by 810 mm (32 in.) wide.

Wheelchair seating *spaces* at *accessible* sections of information, reception and service counters shall incorporate a clear floor space not less than 810 mm (32 in.) by 1370 mm (54 in.).

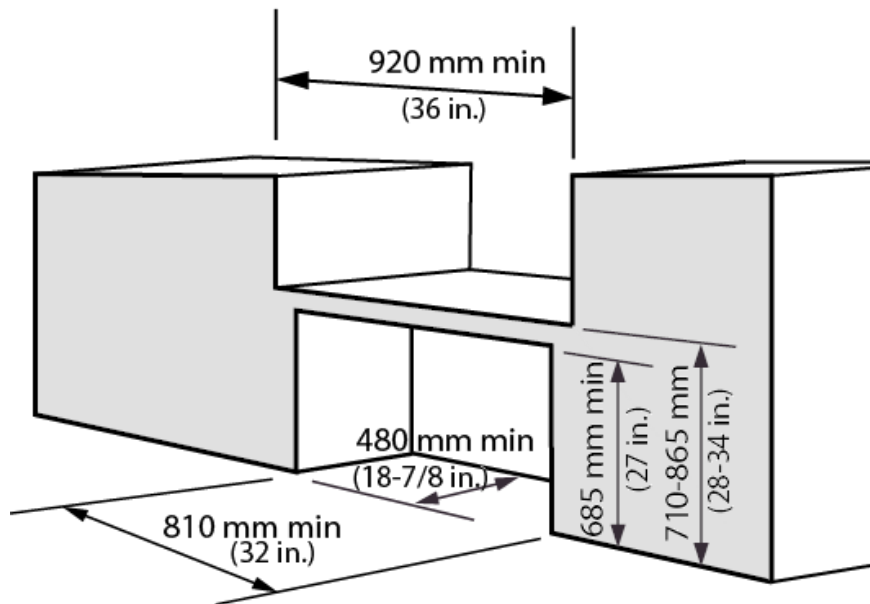
Where a forward approach is used to access a wheelchair seating space, a *clear knee space* of at least 760 mm (30 in.) wide, 480 mm (18-7/8 in.) deep and 685 mm (27 in.) high shall be provided. It may overlap the *clear floor space* by a maximum of 480 mm (18-7/8 in.).

## Exhibit A

Information, reception and service counters shall provide at least one type of Assistive Speaking Device at each counter of varying heights:

- Speech Transfer Intercom System with volume controls for both staff and customers - this can be in a counter system or speaking port;
- gooseneck or cordless microphone; or
- telephone system with voice/ speech amplification.

Where speaking ports are provided at information, reception or service counters, at least one such position shall have a speaking port no higher than 1060 mm (42 in.) above the finished floor or ground.



**Figure 4.3.8.1** Service Counter

### RELATED SECTIONS

- 4.1.1 Space and Reach Requirements
- 4.1.4 Accessible Routes, Paths and Corridors
- 4.4.6 Assistive Listening Systems
- 4.4.7 Signage
- 4.4.10 Information Systems
- 4.4.12 Glare and Light Sources
- 4.4.13 Lighting
- 4.4.14 Materials and Finishes

## 4.4.15 Texture and Colour

## 4.4.16 Acoustics

**4.3.9 STORAGE, SHELVING AND DISPLAY UNITS****RATIONALE**

The heights of storage, shelving and display units should address a full range of vantage points including the lower sightlines of children or a person using a wheelchair or scooter. The lower heights also serve the lower reach of these individuals. Displays that are too low can be problematic for individuals that have difficulty bending down. Appropriate lighting and *colour contrast* is particularly important for persons with a visual *impairment*.

**APPLICATION**

If fixed or built-in storage *facilities*, such as cabinets, closets, shelves and drawers, are provided in *accessible spaces*, at least one of each type provided shall contain storage *space* in compliance with this section.

Shelves or display units allowing self-service by customers in mercantile occupancies shall be located on an *accessible route* complying with 4.1.4.

**DESIGN REQUIREMENTS**

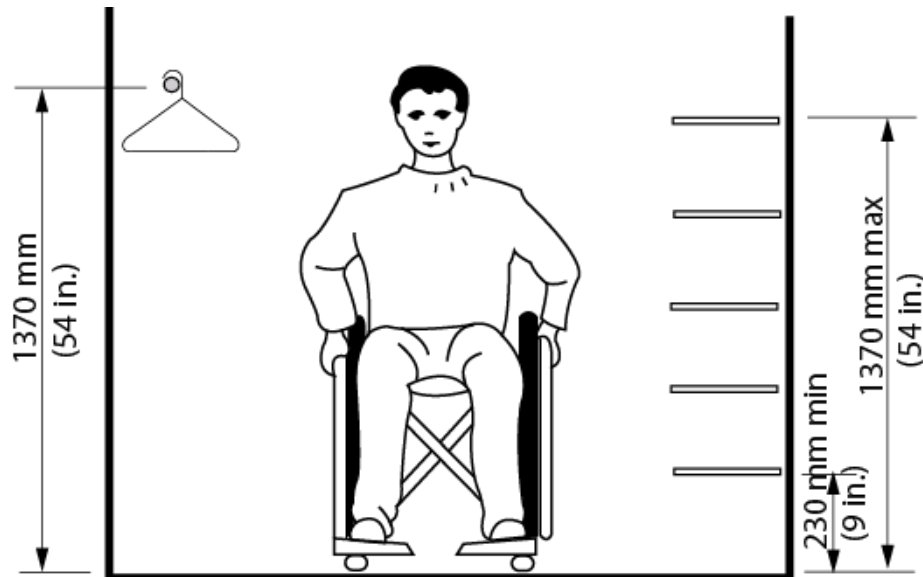
A *clear floor space* at least 810 mm (32 in.) by 1370 mm (54 in.) complying with 4.1.1 that allows either forward or parallel approach by a person using a wheelchair or a scooter shall be provided at *accessible* storage facilities.

*Accessible* storage *spaces* shall be within at least one of the reach ranges specified in 4.1.1. Clothes rods or shelves shall be a maximum of 1370 mm (54 in.) above the finished floor for a side approach. Where the distance from the wheelchair to the clothes rod or shelf is 255 – 535 mm (10-21 in.) (as in closets without *accessible* doors) the height of the rod or shelf shall be no more than 1200 mm (47 in.).

Where coat hooks are provided, they shall all be collapsible coat hooks, mounted no higher than 1200 mm (47 in.) above the floor. (Note: Coat hooks should NOT be located over benches)

Hardware for *accessible* storage *facilities* shall comply with 4.4.2. Touch latches and U-shaped pulls are acceptable.





**Figure 4.3.9.1** Reach Limits for Storage

## RELATED SECTIONS

- 4.1.1 Space and Reach Requirements
- 4.1.4 Accessible Routes, Paths and Corridors
- 4.4.2 Controls and Operating Mechanisms

## 4.3.10 LOCKERS AND BAGGAGE STORAGE

### RATIONALE

In schools, recreational facilities, transit facilities, etc., or wherever public or private storage lockers are provided, at least some of the storage units should be *accessible* by a person using a wheelchair or scooter.

It is preferred to provide an accessible bench in close proximity to *accessible* lockers.

The provision of lockers at lower heights serves the reach restrictions of children or a person using a wheelchair or scooter. The operating mechanisms should also be at an appropriate height and operable by individuals with restrictions in hand dexterity (i.e. operable with a closed fist).

### APPLICATION

If lockers or baggage storage units are provided in *accessible* public or *common use* areas, at least 10%, but not less than one, of the lockers or baggage storage units shall comply with this section.

### DESIGN REQUIREMENTS

*Accessible* lockers and baggage storage units shall be located on an *accessible route* complying with 4.1.4.

## Exhibit A

*Accessible* lockers and baggage storage units shall have their bottom shelf no lower than 230 mm (9 in.) and their top shelf no higher than 1200 mm (47 in.) above the floor or ground. Locks for *accessible* lockers and baggage storage units shall be mounted no higher than 1060 mm (42 in.) from the floor or ground and shall comply with 4.4.2.

Unless all lockers are accessible, accessible lockers shall be identified with a Dynamic Symbol of Access or equivalent.

Numbers or names on all lockers and baggage storage units should be in clearly legible lettering, raised or recessed and of a highly *contrasting* colour or tone (in compliance with the relevant parts of 4.4.7).

Baggage racks or carousels for suitcases, etc. shall have the platform surface no higher than 460 mm (18 in.) from the floor and shall incorporate a continuous *colour contrasting* strip at the edge of the platform surface.

Aisle *spaces* in front of lockers, baggage compartments and carousels should be a minimum of 1370 mm (54 in.) deep and 810 mm (32 in.), to permit forward and lateral approach by a person using a wheelchair or scooter.

Where an accessible bench is installed near accessible lockers, grab bars shall be installed where practicable.

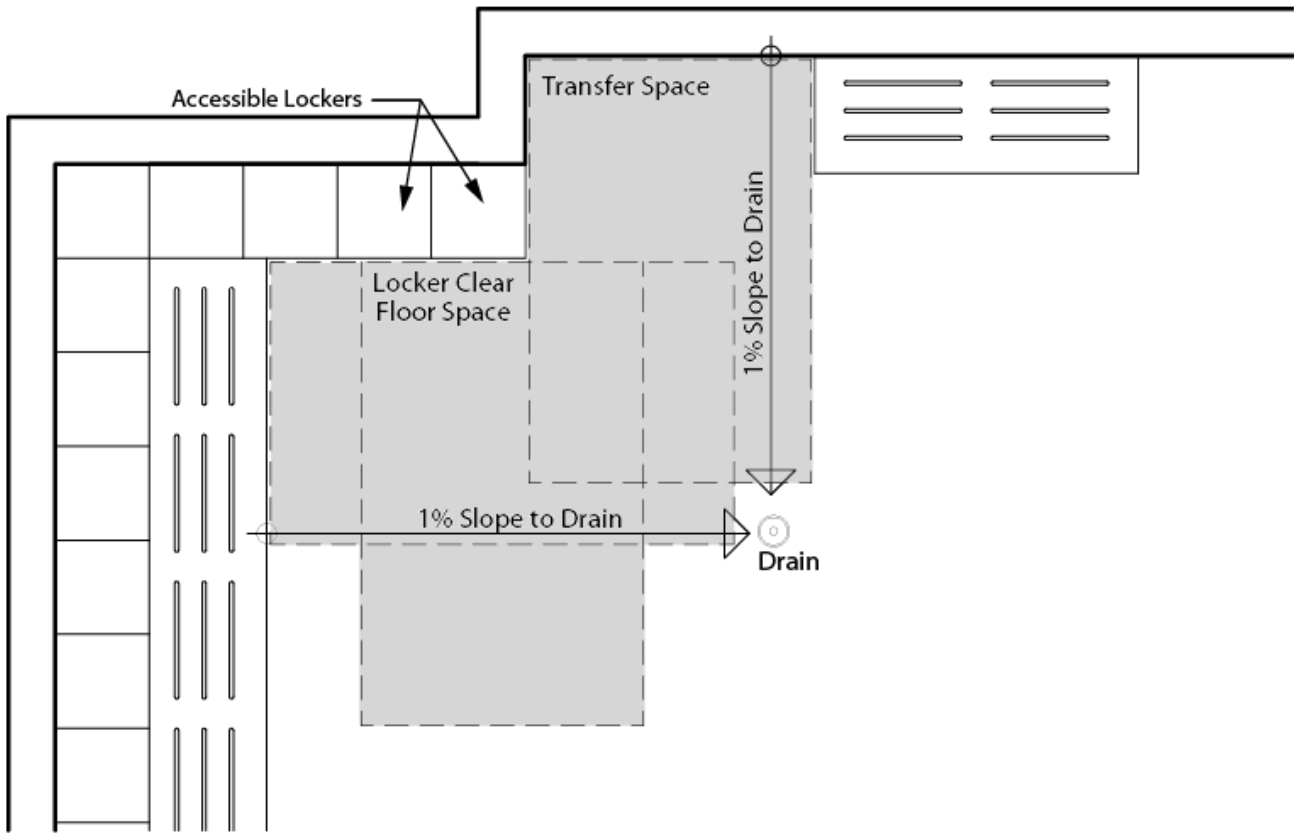
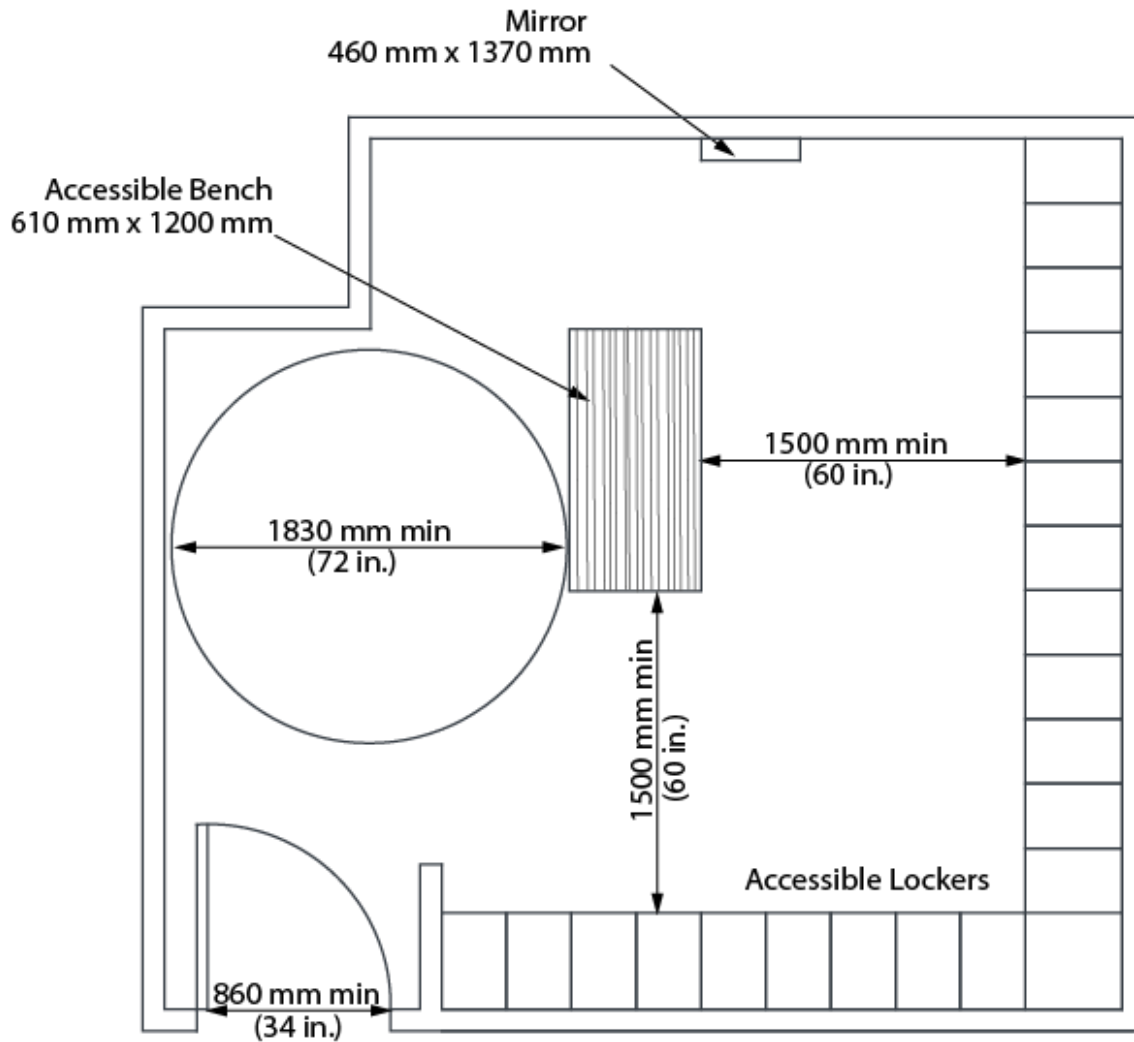


Figure 4.3.10.1 Locker Room Clear Floor Space Requirements



**Figure 4.3.10.2** Locker Room Sample Layout

## RELATED SECTIONS

- 4.1.1 Space and Reach Requirements
- 4.1.4 Accessible Routes, Paths and Corridors
- 4.4.2 Controls and Operating Mechanisms
- 4.4.7 Signage
- 4.4.13 Lighting
- 4.4.15 Texture and Colour

### 4.3.11 BALCONIES, PORCHES, TERRACES AND PATIOS

#### RATIONALE

Where a number of balconies, porches, patios or terraces are provided, it is desirable to consider options for different levels of sun and wind protection. This is of benefit to individuals with varying tolerances for sun or heat. Doors to these spaces typically incorporate large expanses of glazing. These should be appropriately marked to increase their visibility. Thresholds at balcony doors should be avoided.

#### APPLICATION

Balconies, porches, terraces and patios provided for use by the general public, clients, customers or employees shall comply with this section.

#### DESIGN REQUIREMENTS

Balconies, porches, terraces and patios shall

- be located on an *accessible route* complying with 4.1.4; and
- have a minimum depth of 2440 (96 in.). In retrofit situations where providing a depth of 2440 mm (96 in.) is *technically infeasible*, the minimum depth may be reduced to 1525 mm (60 in.); and
- where an outswinging door is used, have a minimum depth of 1100 mm (43-1/4 in.) between the door and any adjacent guard or railing

Exterior balconies, porches, terraces and patios, where directly *accessible* from the interior *spaces*, shall incorporate a threshold in compliance with 4.1.2.

Balcony, porch, terrace and patio surfaces shall

- comply with 4.1.2;
- be sloped to ensure removal of water; and
- be sloped no more than 2%.

Railings and *guards* at balconies, porches, terraces and patios shall comply with the requirements of the Ontario Building Code; and

- be designed to allow *clear* vision below the rail for persons seated in a wheelchair or scooter;
- and incorporate pronounced *colour contrast* between the railings and *guards* and the surrounding environment.

Doors opening out onto balconies shall be located to open against a side wall or rail.

#### RELATED SECTIONS

4.1.1 Space and Reach Requirements

4.1.2 Ground and Floor Surfaces

#### 4.1.4 Accessible Routes, Paths and Corridors

#### 4.1.6 Doors

#### 4.4.14 Materials and Finishes

#### 4.4.15 Texture and Colour

### 4.3.12 PARKING

#### RATIONALE

The location, size and quantity of parking are important factors that collectively contribute to the ease with which persons with a varying range of abilities are able to access *facilities*. Parking specifically intended for persons with mobility challenges must be provided in accordance with the requirements of the Accessibility for Ontarians with Disabilities Act (AODA) and all associated Ontario Regulations (i.e., O.Reg. 413/12). The parking-related standards established in the City's zoning by-law(s) uphold the requirements of the Province and in some instances exceed those requirements. The accessible parking standards offered herein are aligned with the City's zoning by-law requirements and are intended to help identify, remove and prevent barriers for people with disabilities.

#### APPLICATION

The standards presented below apply to all new parking structures and surface parking lots. For existing structures and surface parking lots undergoing renovations/*alterations*, the noted standards should be employed to the greatest extent possible. In all cases, parking must be provided in accordance with the requirements of the City's zoning by-law.

When evaluating the location, size and quantity of parking, particularly for those who may experience barriers to access, consideration shall be given to the following:

- the distance between *accessible parking spaces* and facility entrances with efforts to reduce the distance between an *accessible facility entrance* and accessible parking;
- the avoidance of potential obstructions or accessibility conflicts (e.g., traffic flow crossings, stormwater management facilities, public utilities infrastructure, etc.);
- the impact of weather conditions on ground surface conditions;
- the use of signage to identify parking intended for those with specific accessibility needs;
- the use of ground markings and surface treatment that may facilitate enhanced access;
- the avoidance of physical impediments (e.g., steps, curbs, ditches, etc.) when connecting accessible parking to building entrances / exits;
- the design and size of parking spaces considering specific user needs (e.g., wheelchair use, elevator lifts, etc.);
- the supply of accessible parking in multiple (i.e., unconsolidated) locations when used to accommodate multiple facilities and/or multiple parking areas;
- the delineation of *accessible routes* intended to accommodate greater, unencumbered, access to facilities (e.g., avoid situations where path of travel would need to occur within the vehicle aisle, behind parked vehicles);

## Exhibit A

- the presence of physical barriers along vehicle paths of travel (e.g., structure parking floor heights, location of overhead signage, etc.) considering the height of vehicles which may be equipped with mobility aids (e.g., lifts);
- the presence of physical barriers including speed bumps and pavement slope transitions which may affect vehicles with lowered suspension to accommodate ease of access; and
- the land use for which parking is associated as there may be an enhanced need for accessible parking supply (e.g., retirement homes, hospitals, etc.).

### DESIGN REQUIREMENTS

An *accessible route* shall be provided from each designated parking *space* to an *accessible entrance* into the *facility*.

*Accessible parking spaces* shall be located:

- on an accessible path of travel complying with 4.1.4; and within 30 m (98 ft. 5 in.) of an *accessible* building entrance.

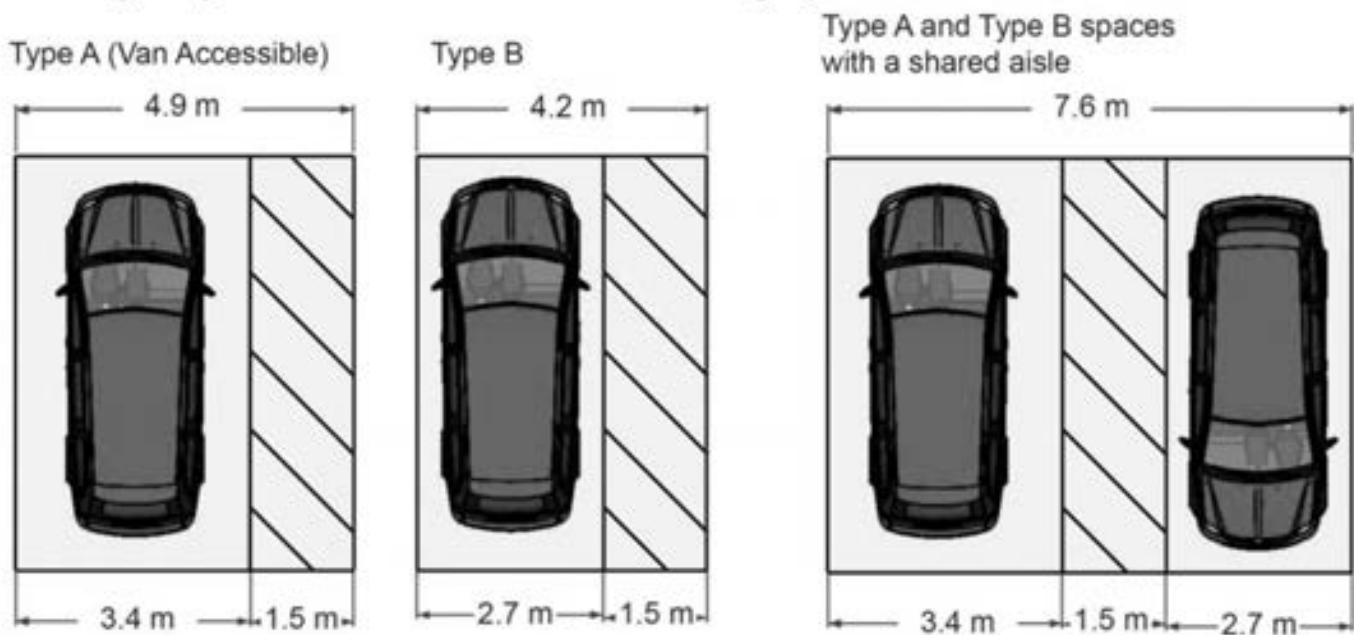
*Accessible parking spaces* and areas shall be designed to:

- have a firm, level surface with a maximum of 1:75 (1.5%) *running slope* for drainage;
- have a maximum *cross slope* of 1:100 (1%);
- have wheel stops placed to provide a minimum 800 mm (31-1/2-in.) clear space for wheelchair access; and
- have curb ramps, where required, to permit access from the parking area to the sidewalk / building entrance.

*Accessible parking spaces* shall be configured as follows:

- pursuant to the standards of the zoning by-law, there are two types of *accessible parking space*. The dimensions of required accessible parking, by type, are:
  - Type A (van accessible) - 3400 mm (134 in.) in width by 6000 mm (236 in.) in length;
  - Type B spaces - 2700 mm (106-1/2 in.) in width by 6000 mm (236-1/4 in.) in length;
- pursuant to the standards of the zoning by-law, *accessible parking spaces* shall be provided alongside an access aisle, which may be shared between *accessible parking spaces*. The access aisle shall
  - have a minimum width of 1500 mm (59 in.) and a minimum length of 6000 mm (236-1/4 in.); and
  - be marked with high tonal contrast diagonal lines;
- pursuant to the standards of the zoning by-law, have a height clearance of at least 2900 mm (114-1/4 in.) at the parking *space*, passenger loading zones, and along access routes to *accessible parking spaces*.

### Zoning Requirements for Accessible Parking Space Dimensions



**Figure 4.3.13.1** Zoning Requirements for Accessible Parking Space Dimensions

*Accessible parking spaces* shall be supplied in the quantities, by type, required by the zoning by-law.

*Accessible parking spaces* shall be signed as follows:

- *Signage of accessible parking spaces* shall incorporate an official designated disabled parking space sign developed by the Ministry of Transportation (1991). Each *accessible parking space* shall be distinctly indicated by erecting an *accessible permit parking* sign that shall be:
  - mounted vertically on a post that is colour contrasted with the background environment;
  - at least 300 mm (11-3/4 in.) wide x 450 mm (17-3/4 in.) tall;
  - installed at a height of 1500 mm (59 in.) to 2500 mm (98-1/2 in.) from the ground surface to the centre line of the sign;
  - for perpendicular parking, centered on the parking space; and
  - for parallel parking, located toward the end of the parking space, on the opposite side from the access aisle.
- For Type A (van accessible) spaces, signage must specify that they are “van accessible”; and
- Where possible signs shall not be mounted on fences or building faces.

*Accessible parking areas* shall be signed as follows:

- Indoor parking facilities shall incorporate a sign at the vehicle entrance indicating the minimum overhead clearance at the parking space and along the vehicle access and egress routes.
- Where the location of *accessible parking spaces* is not obvious or is distant from the approach viewpoints, directional signage shall be placed along the route leading to the designated parking spaces. Such directional *signage* shall incorporate the International Symbol of Access and the appropriate directional arrows.



- Where the location of the nearest *accessible entrance* is not obvious or is distant from the approach viewpoints, directional signs shall be placed along the route leading to the nearest *accessible entrance* to the *facility*. Such directional *signage* will incorporate the symbol of access and the appropriate directional arrows.

**RELATED SECTIONS**

4.1.1 Space and Reach Requirements

4.1.2 Ground and Floor Surfaces

4.1.3 Protruding and Overhead Objects

4.1.4 Accessible Routes, Paths and Corridors

4.1.10 Curb Ramps

4.4.7 Signage

4.4.8 Detectable Warning Surfaces

4.4.13 Lighting

4.4.14 Materials and Finishes

4.4.15 Texture and Colour

**4.3.13 PASSENGER-LOADING ZONES****RATIONALE**

Passenger-loading zones are important features for individuals who may have difficulty in walking distances or those who use parallel transit systems. Accessible transit vehicles typically require *space* for the deployment of lifts or ramps and overhead clearances. Protection from the elements will be beneficial to all users and particularly those that may have difficulty with mobility.

**APPLICATION**

Where passenger-loading zones are provided, at least one shall comply with this section.

*Accessible* passenger-loading zones shall be identified with *signage* complying with applicable provisions of 4.4.7.

If the passenger-loading zone is a designated mobility transit stop zone, it shall comply with all relevant municipal bylaws.

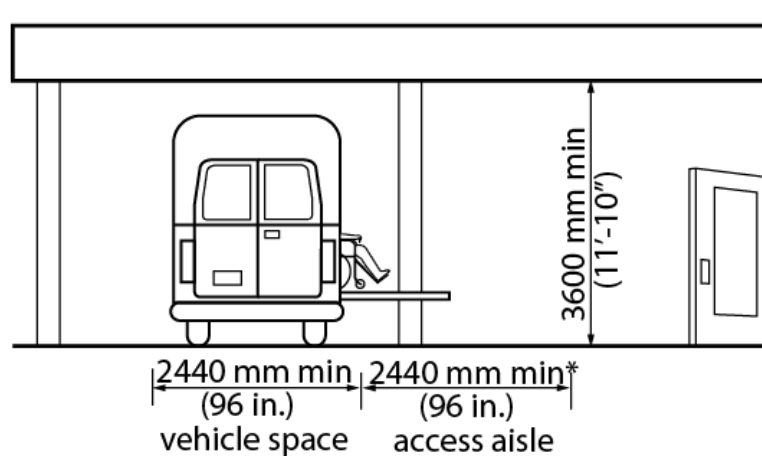
A passenger loading zone typically includes a driveway, a lay-by for the stopped vehicles, the access aisle for the loading and unloading, and the pedestrian *path of travel*.

Bollards between the access aisle and the lay-by can be used to prevent vehicles from pulling into the access aisle.

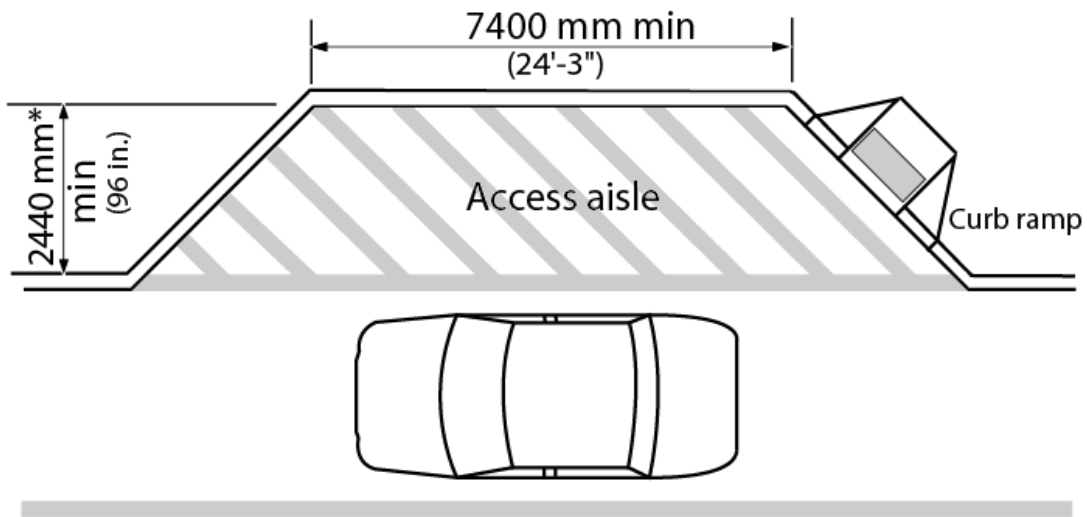
**DESIGN REQUIREMENTS**

Passenger-loading zones shall

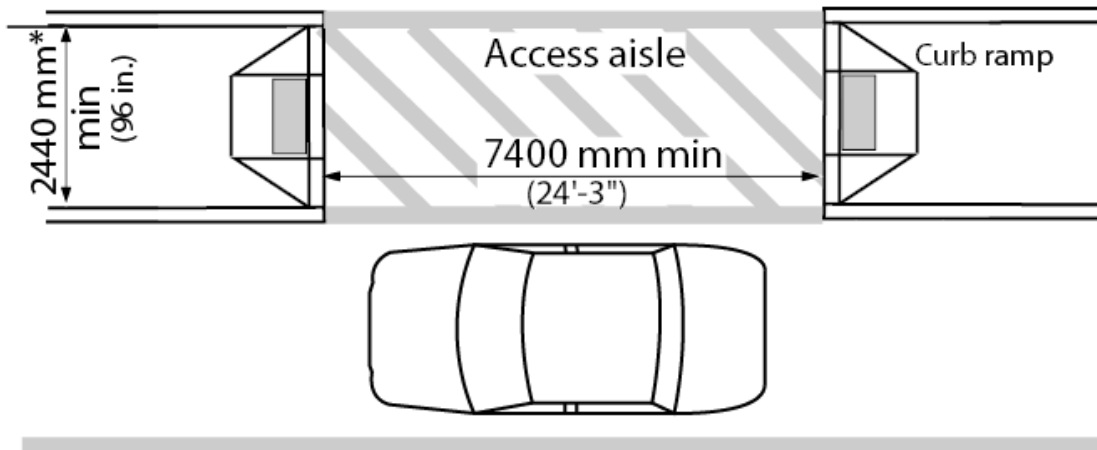
- be on an *accessible route* complying with 4.1.4;
- provide an *access aisle* that is
  - at least 2440 mm (96 in.) wide and 7400 mm (23 ft.) long, adjacent and parallel to the vehicle pull-up *space*. (In a retrofit situation where providing a 2440 mm (96 in.)-wide *access aisle* is *technically infeasible*, the *access aisle* width may be reduced to 2000 mm (78-3/4 in.); and
  - separated from the walkway either by a curb containing a curb ramp that complies with 4.1.10 or by a detectable warning surface that complies with 4.4.8.
- have a *curb ramp* complying with 4.1.10 where there are curbs between the *access aisle* and the vehicle pull-up *space*;
- have a minimum vertical clearance of 3600 mm (11.8 ft.) at the loading zone and along the vehicle access route to such areas to and from the *site entrances*; and,
- where feasible, be covered by a roof or canopy.



**Figure 4.3.13.1** Clearances at Passenger Loading Zone



**Figure 4.3.13.2** Passenger Loading Zone



**Figure 4.3.13.3** Alternate Passenger Loading Zone Configuration

\* Note: In a retrofit situation where it is *technically infeasible* to provide the required *access aisle* width, the aisle width may be reduced to 2000 mm (78-3/4 in.).

## RELATED SECTIONS

- 4.1.1 Space and Reach Requirements
- 4.1.2 Ground and Floor Surfaces
- 4.1.3 Protruding and Overhead Objects
- 4.1.4 Accessible Routes, Paths and Corridors
- 4.1.10 Curb Ramps

4.4.7 Signage

4.4.8 Detectable Warning Surfaces

4.4.13 Lighting

4.4.14 Materials and Finishes

4.4.15 Texture and Colour

## 4.3.14 LANDSCAPING MATERIALS AND PLANTINGS

### RATIONALE

The selection of and location of landscape materials, trees, shrubs and plants should consider a wide variety of users.. For instance, plants and shrubs with a variety of fragrances can provide an interesting orientation cue for persons with a visual *impairment*. Using *contrasting* flowers near walkways can also be helpful as a guide. Plants with thorns may constitute a walking hazard. Plants that drop large seed pods can present slipping hazards, as well as difficulties for pushing a wheelchair. Plantings and tree limbs that overhang pathways can impede all users and be a particular hazard to an individual with a visual *impairment*.

Raised beds can better accommodate persons who use a mobility device or those that have difficulty in bending to enjoy or tend to plantings.

The use of unit pavers as a walking/wheeling surface is recommended only if laid with a construction detail that minimizes the effects of settlement and frost heave..

### APPLICATION

Landscaping materials and plantings contained within the site shall comply with this section.

### DESIGN REQUIREMENTS

The edges of planting beds located immediately adjacent to pedestrian *walkways* shall incorporate clearly defined, cane-detectable curbs at least 75 mm (3 in.) high.

Where variations in grading immediately adjacent to pedestrian *walkways* are potentially hazardous (particularly to persons who are visually impaired), the hazardous edges of the *walkway* shall incorporate clearly defined, cane-detectable curbs at least 75 mm (3 in.) high.

Shrubs with thorns and sharp edges shall be planted at least 920 mm (36 in.) away from *accessible* pathways and seating areas.

Consider positioning plants that drop large seed pods so they do not overhang or are near *accessible* paths or walkways.

Permanent guy wires shall not be used in any area which is intended for use by the general public, clients, customers or employees. Temporary guy wires, such as those used when planting new trees,

## Exhibit A

shall be oriented to reduce risk of conflict with neighbouring uses, such as pathway travel. Colour contrast or other methods to improve visible detection of guy wires should be considered.

Tree *guards* shall conform to 4.1.3. Overhanging branches of trees or shrubs over walkways or paths shall not reduce the available headroom at any part of the *walkway* or path to less than 2100 mm (82-3/4 in.).

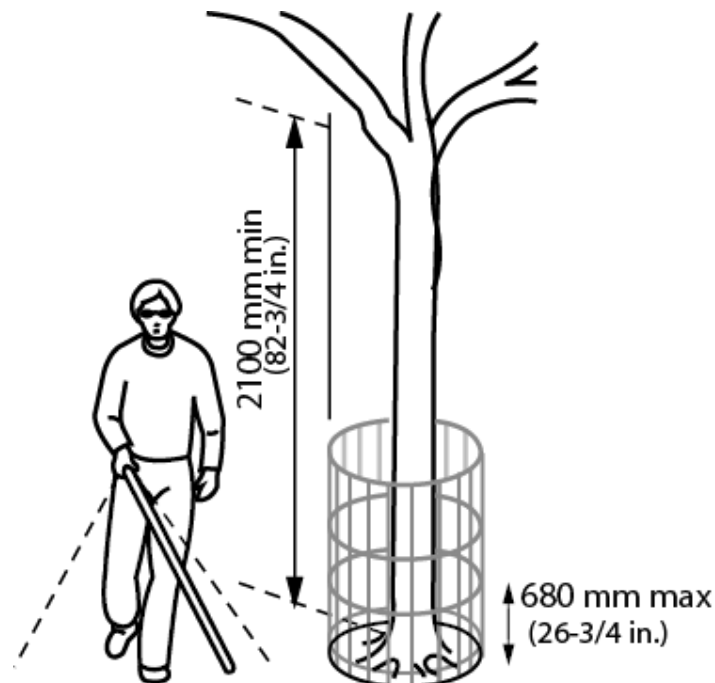


Figure 4.3.14.1 Tree Guard

### RELATED SECTIONS

- 4.1.1 Space and Reach Requirements
- 4.1.2 Ground and Floor Surfaces
- 4.1.3 Protruding and Overhead Objects
- 4.1.4 Accessible Routes, Paths and Corridors
- 4.4.8 Detectable Warning Surfaces
- 4.4.14 Materials and Finishes

### 4.3.15 BENCHES

#### RATIONALE

Benches provide convenient resting places for all individuals and are especially important for those who may have difficulty with standing or walking for extended periods. Benches should be placed adjacent to pedestrian walkways to provide convenient rest places without becoming potential obstructions. Appropriate seat heights can facilitate sitting and rising for individuals such as senior

citizens. Armrests may also provide assistance in sitting and rising. A person with a visual *impairment* may find it easier to locate benches if they are located adjacent to a landmark, such as a large tree, a bend in a pathway, or a sound source.

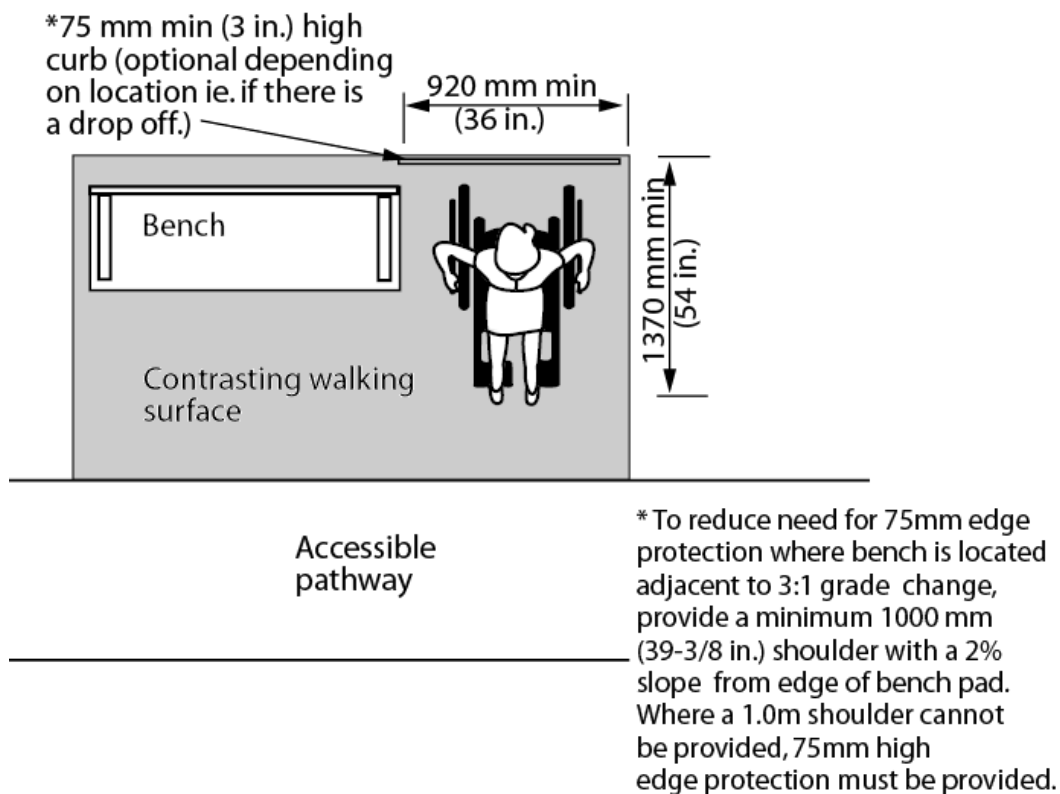
**APPLICATION**

All benches, except those located in unpaved areas of *parks*, wilderness, beach or unpaved picnic areas, shall be *accessible* to persons using wheelchairs or other mobility devices.

**DESIGN REQUIREMENTS**

Benches shall

- be adjacent to an *accessible route* complying with 4.1.4;
- be stable;
- have a seat height between 450 mm (17-3/4 in.) and 500 mm (19-5/8 in.) from the ground;
- have arm and back rests;
- be of *contrasting* colour to their background; and
- have an adjacent level, firm ground surface at least 920 mm (36 in.) x 1370 mm (54 in.).



**Figure 4.3.15.1 Rest Area**



**Figure 4.3.15.2** Bench Seating

## RELATED SECTIONS

- 4.1.1 Space and Reach Requirements
- 4.1.2 Ground and Floor Surfaces
- 4.1.3 Protruding and Overhead Objects
- 4.1.4 Accessible Routes, Paths and Corridors
- 4.4.8 Detectable Warning Surfaces
- 4.4.14 Materials and Finishes
- 4.4.15 Texture and Colour

## 4.3.16 PUBLIC USE EATING AREAS

### RATIONALE

Tables with an extension of the table surface make them *accessible* to a person using a wheelchair. A firm, level surface around the table, with an *accessible* path leading to the table, is required for wheelchair accessibility. A change in texture from a pathway to the table area is an important cue for a person with a visual impairment.

Tables that have the support leg(s) in the centre of the table provide a higher level of accessibility

### APPLICATION

If tables are provided in an *accessible* public or *common use* area, at least 20%, but not less than one, for each cluster of picnic tables shall comply with this section. It is preferable to have all tables comply with this section.

Table seating should provide a variety of locations that allow a choice of view, sun or shade, and protection from outdoor elements such as wind or rain.

Ensure that chairs with and without armrests, as well as bariatric seating, is provided for banquet halls, restaurants and cafeterias.

### DESIGN REQUIREMENTS

*Accessible* picnic tables shall

- have an *accessible route* leading to the table, and be adjacent to an *accessible route* complying with 4.1.4;
- have knee *space* under the table at least 810 mm (32 in.) wide by 480 mm (19 in.) deep and 685 mm (27 in.) high;
- have its top surface located between 810 mm (32 in.) to 865 mm (34 in.) above the finished floor or ground surface;
- be of *contrasting* colour to their background;

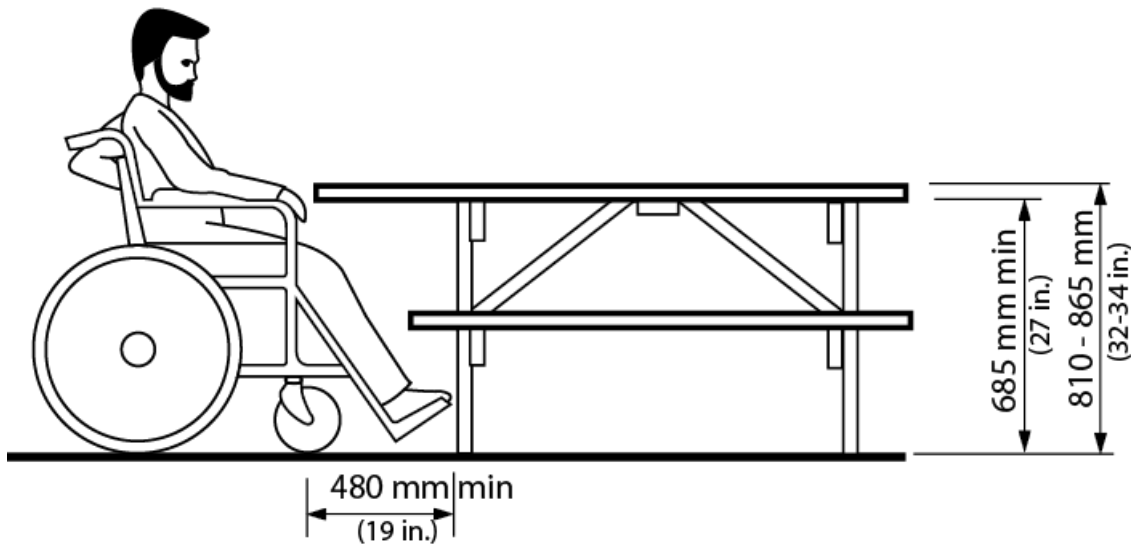


## Exhibit A

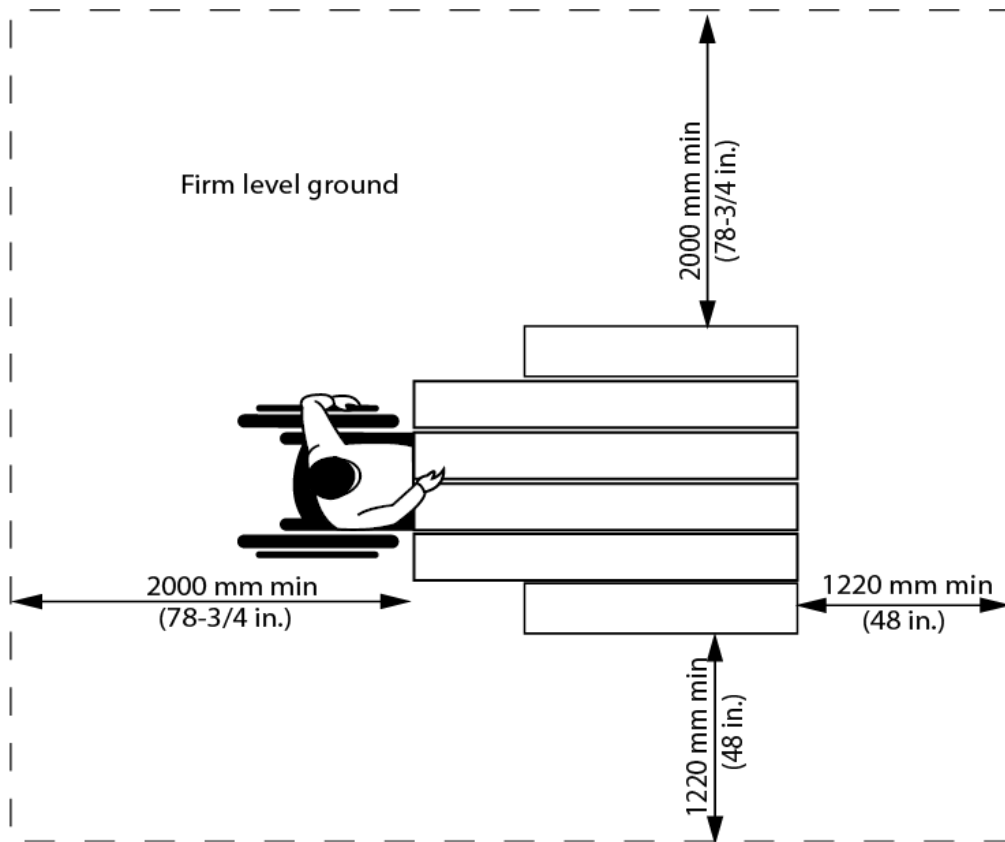
- have a level, firm ground surface extending min. 2000 mm (78-3/4 in.) where *accessible space* is provided at a picnic table for persons who use wheelchairs or scooters and min. 1220 mm (48 in.) on all the other sides; and
- be secured to a concrete pad.

Illumination is a consideration when positioning outdoor eating areas. Lighting should comply with the requirements of 4.4.13.

In a retrofit situation where it is technically infeasible to provide the required level surface, the dimensions may be reduced to min. 1220 mm (48 in.) on all sides.



**Figure 4.3.16.1** Height and Knee Space at Accessible Tables



**Figure 4.3.16.2 Accessible Tables**

## RELATED SECTIONS

- 4.1.1 Space and Reach Requirements
- 4.1.2 Ground and Floor Surfaces
- 4.1.3 Protruding and Overhead Objects
- 4.1.4 Accessible Routes, Paths and Corridors
- 4.4.8 Detectable Warning Surfaces
- 4.4.13 Lighting
- 4.4.14 Materials and Finishes
- 4.4.15 Texture and Colour

## 4.3.17 STREETSCAPES

### RATIONALE

Street furniture can provide a resting place for any individual with difficulty walking distances. Such furniture should incorporate strong colour contrasts and be located off pathways, to minimize its potential as an obstruction to pedestrians.

*Clear paths of travel* are important to all individuals using sidewalks and *pathways*.

Streetscape elements such as newspaper boxes, trash bins, outdoor patios and bus shelters present a barrier to all pedestrians, especially those that require additional *space* for use of wheelchairs, scooters, strollers or delivery carts. For persons with a visual *impairment*, unidentified obstructions within *pathways* can present a hazard.

The efficient and thorough removal of snow and ice are also essential to outdoor *pathways*.

### APPLICATION

Streetscape elements furniture, including but not limited to, waste receptacles, light standards, signs, planters, mail boxes, vending machines, benches, traffic signals and utility boxes located along sidewalks or *paths of travel* and contained within the *site*, shall comply with this section, including furniture streetscape elements that is located inside or outside of *facilities*.

All waste receptacles, except those located in unpaved areas of *parks*, wilderness, beach or unpaved picnic areas or large industrial containers, shall be *accessible* to persons using wheelchairs or other mobility devices.

### DESIGN REQUIREMENTS

Clearances along pedestrian routes must comply with 4.1.3.

Streetscape elements shall

- not reduce the required width of the *accessible route*;
- be cane-detectable, in compliance with 4.1.3;
- be consistently located to one side of the *accessible route*, entirely within an amenity strip that is hard-surfaced, at least 600 mm (23-5/8 in.) wide, and is identified using an *indicator surface*;
- be securely mounted within an amenity strip, minimum 600 mm (23-5/8 in.) wide, located adjoining *walkways*, *paths of travel*, sidewalks and other *accessible routes*; and
- incorporate pronounced *colour contrast* to differentiate it from the surrounding environment.

Waste receptacles and recycling bins shall be large enough to contain the anticipated amount of waste, so that overflows do not cause a tripping hazard.

Permanent waste receptacles and recycling bins in *accessible* open areas, such as *parks*, wilderness areas, beaches or picnic areas, should be mounted on firm, level pads adjacent to the *path* or sidewalk (but not directly beside seating areas).

## Exhibit A

Waste receptacles and recycling bins shall be clearly identified by suitable lettering, in compliance with the relevant parts of 4.4.7.

Where lids or openings are provided on permanent waste receptacles and recycling bins, they shall be mounted no higher than 1060 mm (42 in.) above the adjacent floor or ground surface. Opening mechanisms shall be operable

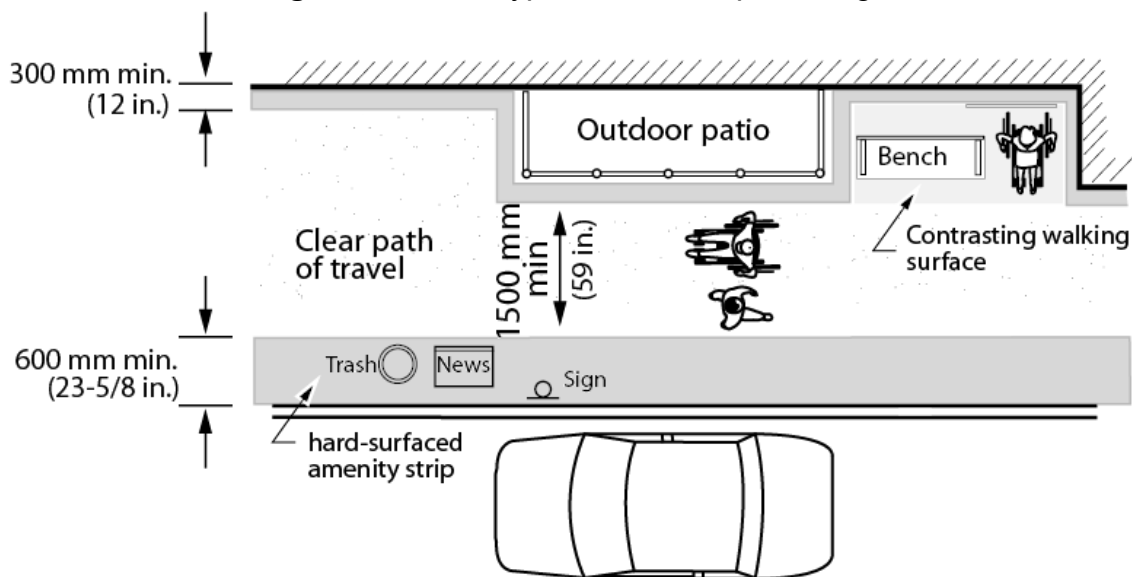
- without tight grasping, pinching, or twisting of the wrist;
- with a closed fist; and
- with a force of not more than 22.2 N.

An exterior waste receptacle shall be provided close to each *accessible public entrance*.

Where mailboxes are provided on a *site* for facility and/or community access, they shall

- be located immediately adjacent to an *accessible route*;
- incorporate a *clear* area at least 760 mm (30 in.) wide x 1370 mm (54 in.) long in front of usable parts;
- have slots for posting mail located to be reachable from a seated position;
- have at least 10%, but no less than one, mailbox for collecting mail, located to be reachable from a seated position;
- have operating mechanisms in compliance with 4.4.2; and
- be kept *clear* of snow.

**Figure 4.3.17.1 Typical Streetscape Configurations**



**Figure 4.3.17.2 Streetscape**

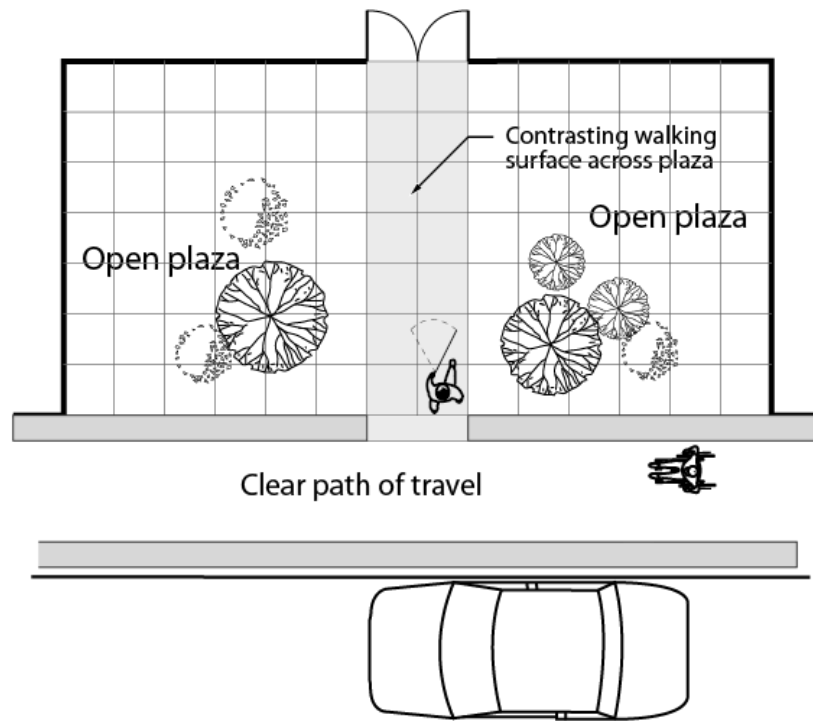


Figure 4.3.17.3 Pathway Across Open Plaza

**RELATED SECTIONS**

- 4.1.1 Space and Reach Requirements
- 4.1.2 Ground and Floor Surfaces
- 4.1.3 Protruding and Overhead Objects
- 4.1.4 Accessible Routes, Paths and Corridors
- 4.1.6 Doors
- 4.1.10 Curb Ramps
- 4.3.1 Drinking Fountains
- 4.3.11 Balconies, Porches, Terraces and Patios
- 4.3.12 Parking
- 4.3.13 Passenger Loading Zones
- 4.3.15 Benches
- 4.3.16 Public Use Eating Areas
- 4.3.19 Service Animal Relief Areas

4.4.3 Vending and Ticketing Machines

4.4.5 Public Telephones

4.4.7 Signage

4.4.8 Detectable Warning Surfaces

4.4.13 Lighting

4.4.14 Materials and Finishes

## **4.3.18 KITCHENS AND KITCHENETTES**

### **RATIONALE**

Kitchens, kitchenettes and coffee stations require an appropriate level of access to be useable by persons with disabilities. Adequate maneuvering space is required for users of mobility equipment to approach and use work surfaces, storage elements and appliances. A frontal approach to work surfaces and appliances is generally preferred, except at refrigerators where a side approach is preferred. Where a frontal approach is used, knee space and toe space are required.

The use of *colour contrast* between kitchen elements will assist persons with low vision locate surfaces, appliances and controls. Darker coloured work surfaces are preferable as they make it easier to identify objects located on them.

### **APPLICATION**

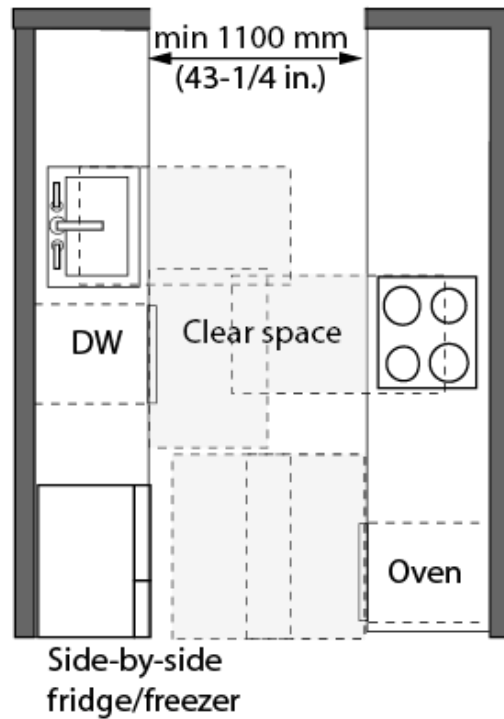
Kitchens and kitchenettes intended for use by staff or the public shall comply with this section. Exception: Commercial kitchens.

At least 50% of shelf *space* in storage facilities shall comply with this section.

### **DESIGN REQUIREMENTS**

Pass-through kitchens shall have

- where counters, appliances or cabinets are on two opposing sides, or when counters, appliances or cabinets are opposite a parallel wall, clearance between all opposing base cabinets, counter tops, appliances, or walls within a kitchen work area of 1100 mm (43-1/4 in.) minimum; and
- two entries.



**Figure 4.3.18.1** Pass-Through Kitchen

U-shaped kitchens enclosed on three continuous sides shall have a minimum clearance of 2440 mm (96 in.) between all opposing base cabinets, counter tops, appliances, or walls within kitchen work areas. In a retrofit situation where providing a 2440 mm (96 in.) *space* is *technically infeasible*, this *space* may be reduced to 2130 mm (84 in.).

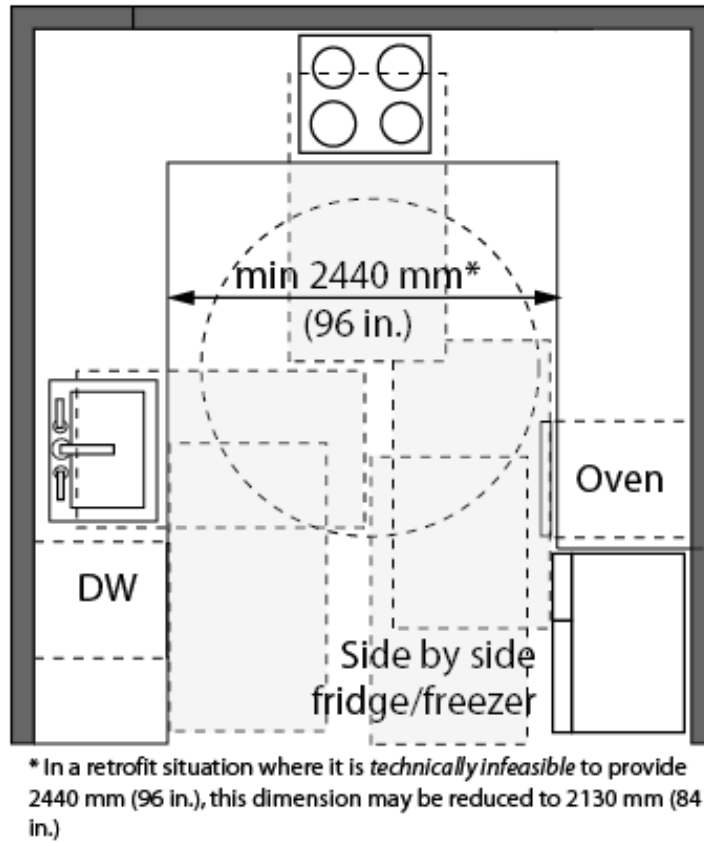


Figure 4.3.18.2 U-Shaped Kitchen

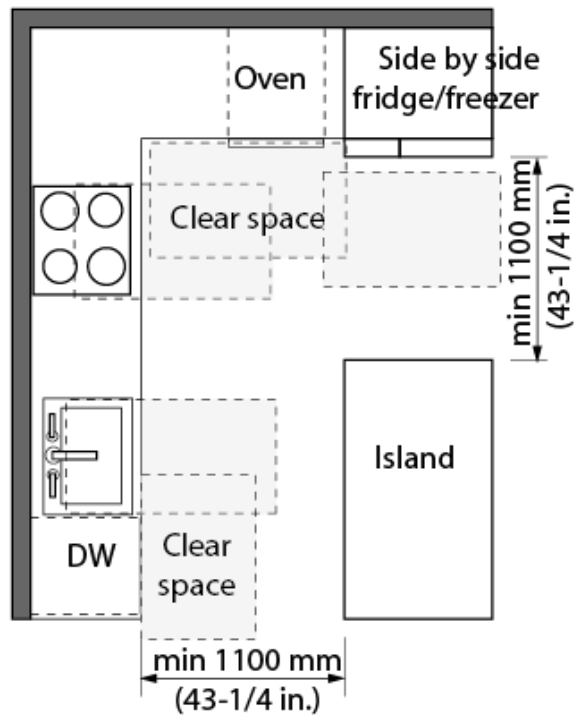
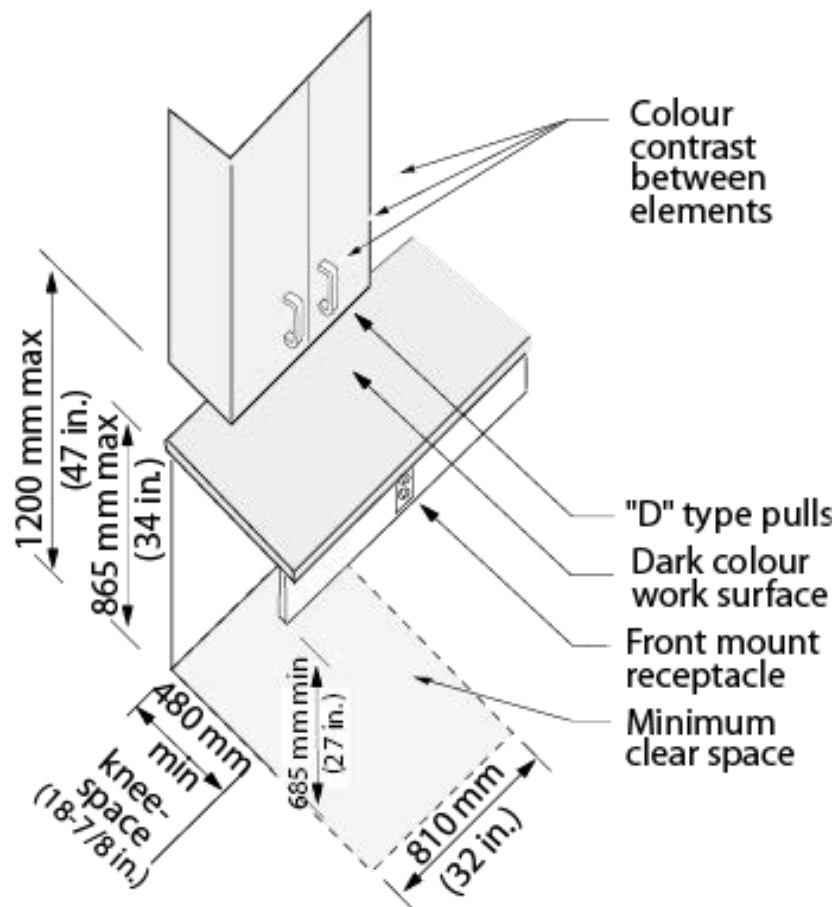


Figure 4.3.18.3 L-Shaped Kitchen with Island



Storage elements shall

- be located on an accessible route with adjacent *clear floor space* in compliance with 4.1.1;
- comply with at least one of the reach ranges specified in 4.1.1; and
- incorporate *operable portions* in compliance with 4.4.2.



**Figure 4.3.18.4** Storage Elements

Kitchen sinks shall

- be located on an accessible route with adjacent *clear floor space* for a forward approach. Exceptions: A parallel approach is permitted to a kitchen sink where a cook top or conventional range is not provided and to wet bars;
- where a forward approach is provided, incorporate knee space below at least 810 mm (32 in.) wide, 480 mm (18-7/8 in.) deep, and 685 mm (27 in.) high;
- have the height of the rim or the counter top (whichever is higher) 710–856 mm (28-34 in.);
- incorporate faucets and other controls in compliance with 4.4.2;
- have water supply and drain pipes under the sink insulated or otherwise configured to protect against contact; and
- incorporate no sharp or abrasive surfaces under the sink.

Kitchen appliances shall

## Exhibit A

- be located on an accessible route with adjacent *clear floor space* in compliance with 4.1.1; and
- incorporate controls and *operable portions* in compliance with 4.4.2. Exceptions: Appliance doors and door latching devices.

Dishwashers shall incorporate *clear floor space* adjacent to the dishwasher door. The dishwasher door, in the open position, shall not obstruct the *clear floor space* for the dishwasher or the sink.

Ranges and cooktops shall

- incorporate controls that are located to avoid reaching across the burners; and
- where a forward approach is provided
  - incorporate knee space below at least 810 mm (32 in.) wide, 480 mm (18-7/8 in.) deep, and 685 mm (27 in.) high; and
  - insulate or otherwise configure the appliance to prevent burns, abrasions, or electrical shock.

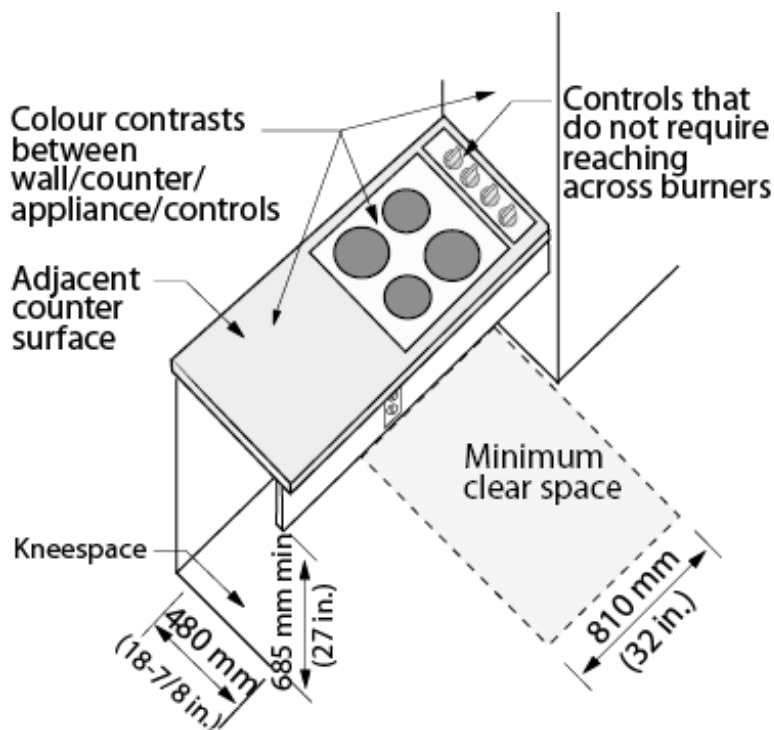
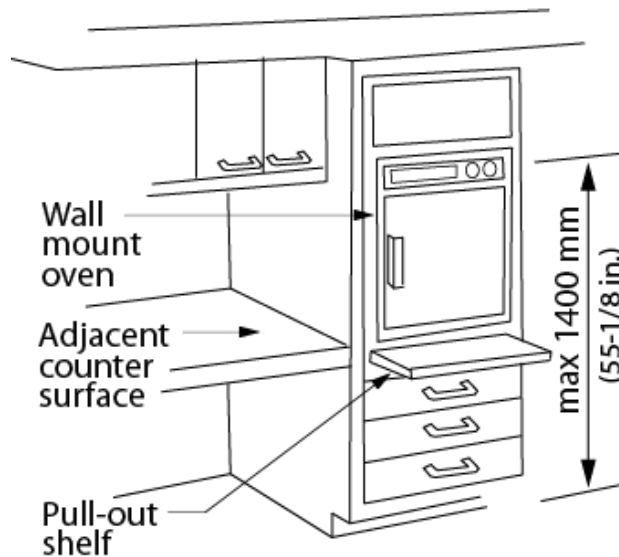


Figure 4.3.18.6 Cook Top

Ovens shall

- have controls located on the front panels, mounted no higher than 1400 mm (55-1/8 in.);
- where side-hinged doors are used, be located with an adjacent work surface positioned adjacent to the latch side of the door;
- incorporate a pull-out shelf below the oven; and
- where bottom-hinged doors are used, be located with an adjacent work surface positioned adjacent to one side of the door.



**Figure 4.3.18.8** Wall-Mounted Oven

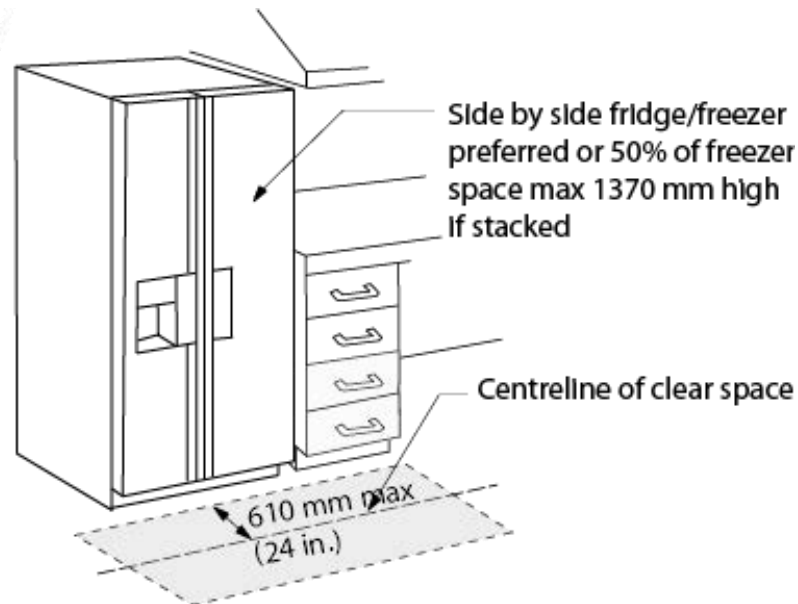
In facilities with children's programs, ranges, cooktops and ovens shall be equipped with a safety switch to de-activate appliance controls.

Microwaves shall

- have controls located on the front panels, mounted between 230 mm (9-1/16 in.) and 1400 mm (55-1/8 in.); and
- where side-hinged doors are used, be located with a work surface positioned adjacent to the latch side of the door.

Refrigerators/freezers shall

- be configured with at least 50% of the freezer space maximum 1370 mm (54 in.) above the floor; and
- incorporate clear floor space in front, positioned for a parallel approach immediately adjacent to the refrigerator/freezer, with the centre-line of the clear floor space offset 610 mm (24 in.) maximum from the front face of the refrigerator/freezer.



**Figure 4.3.18.7** Fridge/Freezer

Kitchen elements shall incorporate *colour contrast* to visually differentiate the cabinets and appliances from adjacent wall and floor surfaces, the countertop from the cabinets and adjacent walls, and operable hardware on cabinets.

Every area where food is intended to be processed, prepared or manufactured and where equipment or utensils are intended to be cleaned shall be equipped to provide illumination to a level of not less than 500 lux measured at the floor level.

Every storage room, dressing room, sanitary facility, service area and corridor serving the areas where food is intended to be processed, prepared or manufactured and where equipment or utensils are intended to be cleaned is be equipped to provide illumination to a level of not less than 300 lux measured at the floor level.

## **RELATED SECTIONS**

- 4.1.1 Space and Reach Requirements
- 4.1.2 Ground and Floor Surfaces
- 4.1.3 Protruding and Overhead Objects
- 4.1.4 Accessible Routes, Paths and Corridors
- 4.4.12 Glare and Light Sources
- 4.4.13 Lighting
- 4.4.14 Materials and Finishes
- 4.4.15 Texture and Colour

### 4.3.19 SERVICE ANIMAL RELIEF AREAS

#### RATIONALE

Persons who use a guide dog, who are accompanied by a working companion dog or who utilize other service animals to assist them with mobility, require access to an area for their service animal to relieve themselves. Such service animal relief areas need to be in an accessible location, feature good drainage and provide a garbage can for waste disposal.

#### APPLICATION

Service animal relief areas should be provided near large public facilities, such as community centres, arenas, sports fields, parks and outdoor recreation areas, any building where a service animal owner is employed, and in buildings of assembly occupancy which incorporate a meeting space for 50 or more people.

#### DESIGN REQUIREMENTS

Service animal relief areas shall

- be adjacent to an accessible route complying with 4.1.4;
- be located within 30 metres (98 ft. 5 in.) of an accessible entrance;
- be an unobstructed, dedicated space at least 1500 x 1500 mm (59 x 59 in.) in size;
- incorporate a ground surface with drainage (Note: grass is preferable to gravel);
- incorporate a garbage can in compliance with 4.3.17;
- be located away from busy traffic areas such as vehicular access routes and loading docks;  
and
- be identified by signage saying “Service Animal Relief Area” complying with 4.4.7.

#### RELATED SECTIONS

4.1.4 Accessible Routes, Paths and Corridors

4.3.17 Streetscapes

4.4.7 Signage

## 4.4 SYSTEMS AND CONTROLS

### 4.4.1 EMERGENCY EXITS, FIRE EVACUATION AND AREAS OF RESCUE ASSISTANCE

#### RATIONALE

In order to be *accessible* to all individuals, emergency exits must include the same accessibility features as other doors specified in 4.1.6. The doors and routes must also be marked in a way that is *accessible* to all individuals, including those who may have difficulty with literacy, such as children or persons speaking a different language. Persons with a visual *impairment* will need a means of quickly

locating exits – audio or talking signs could assist. In the event of fire when elevators cannot be used, areas of rescue assistance are an asset to anyone who would have difficulty traversing sets of stairs.

**APPLICATION**

In *facilities*, or portions of *facilities*, required to be *accessible*, *accessible means of egress* shall be provided in the same number as required for exits by the Ontario Building Code.

Where required exits from a floor level are not *accessible*, *areas of rescue assistance* shall be provided on the floor level in a number equal to that of the required exits.

Every *occupiable* level in non-residential occupancies above or below the first *storey* (as defined by the Ontario Building Code) that is *accessible*, shall

- be served by an elevator that has protection features, as specified in the Ontario Building Code; or
- be divided into at least two zones by fire separations, as specified in the Ontario Building Code.

In *occupiable* levels above or below the first *storey* in residential occupancies, the requirements for a protected elevator or two fire zones may be waived, if an appropriate balcony (as specified in the Ontario Building Code) is provided for each suite.

Areas of rescue assistance shall comply with this section.

A horizontal exit meeting the requirements of the Ontario Building Code shall satisfy the requirements for an *area of rescue assistance*.

**DESIGN REQUIREMENTS**

Where emergency warning systems are provided, they shall include both audible alarms and visible alarms. Visual alarms shall comply with 4.4.4.

*Accessible means of egress* shall comply with 4.1.4.

*Accessible means of egress* shall be identified with *signage* in compliance with the applicable provisions of 4.4.7.

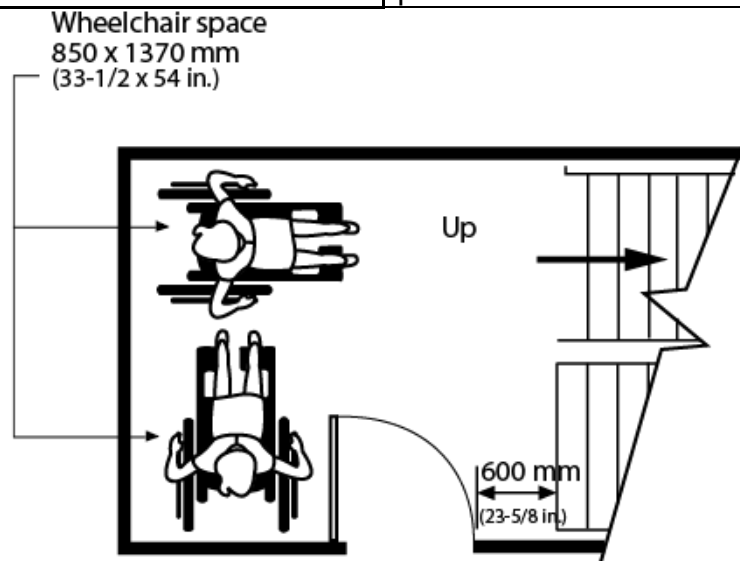
Optional: Evacuation chairs may be placed at significant areas where applicable.

*Areas of rescue assistance* shall

- be located on an *accessible route* complying with 4.1.4;
- incorporate the number of rescue *spaces* in accordance with Table 4.4.1;
- be of a size that allows a minimum floor *space* of 850 mm (33-1/2 in.) x 1370 mm (54 in.) per non-ambulatory occupant;
- be separated from the floor area by a fire separation having a fire resistance rating at least equal to that required for an exit;
- be served by an exit or firefighters' elevator;

- be designated as an *area of rescue assistance* for persons with disabilities on the *facility* plans and in the *facility*;
- be smoke protected in *facilities* of more than three *storeys*;
- incorporate a 2-way voice communication system for use between each area of rescue assistance and the central alarm and control facility; and
- be identified with signage in compliance with the applicable provisions of 4.4.7, stating AREA OF RESCUE ASSISTANCE and incorporating the international symbol for accessibility for disabled persons.

| <b>Table 4.4.1 Number of rescue spaces</b>                                     |  |
|--|--|
| <b>Occupant load of the floor area served by the area of rescue assistance</b> | <b>Minimum number of rescue spaces</b>   |
| 1 to 400   | 2  |
| Over 400   | 3 plus 1 for each additional increment of 200 persons in excess of 400 persons |



**Figure 4.4.1.1 Area of Rescue Assistance**

**RELATED SECTIONS**

- 4.1.1 Space and Reach Requirements
- 4.1.2 Ground and Floor Surfaces
- 4.1.3 Protruding and Overhead Objects
- 4.1.4 Accessible Routes, Paths and Corridors
- 4.1.6 Doors
- 4.4.2 Controls and Operating Mechanisms
- 4.4.4 Visual Alarms

#### 4.4.6 Signage

#### 4.4.8 Detectable Warning Surfaces

#### 4.4.9 Public Address Systems

#### 4.4.14 Materials and Finishes

#### 4.4.15 Texture and Colour

### 4.4.2 CONTROLS AND OPERATING MECHANISMS

#### RATIONALE

Operating mechanisms that require a high degree of dexterity or strength will be difficult for many people to use. They can also be obstacles for children, individuals with arthritis or even someone wearing gloves. Controls that require two hands to operate can also be difficult for some people, particularly those with reach or balance limitations, or those who must use their hands to hold canes or crutches.

The placement of controls is integral to their accessibility. For the individual using a wheelchair, the height of the controls and the space to position the wheelchair in front of the controls are important. Controls placed high on a wall are also difficult for children or persons of short stature.

Individuals with a visual *impairment* may have difficulty with flush-mounted buttons, touch screens or controls without tactile markings. Controls that contrast in colour from their background, including *colour contrasted* raised letters, may

be easier to find by an individual with a visual *impairment*. Persons with cognitive challenges may find counterintuitive controls or graphics difficult.

#### APPLICATION

Controls and operating mechanisms generally used by staff or public (e.g., light switches and dispenser controls) shall comply with this section. Exception: Restricted-access controls.

#### DESIGN REQUIREMENTS

A *clear*, level floor area at least 760 mm x 1370 mm (30 in. x 54 in.) shall be provided at controls and operating mechanisms, such as dispensers and receptacles.

The *operable portions* of controls and operation of *building* services or safety devices, including mechanisms such as electrical switches and intercom switches, shall be located between 900 mm (35-1/2 in.) and 1100 mm (43 in.) from the floor. Thermostats and manual pull stations shall be mounted 1200 mm (47-1/4 in.) above the floor. Exceptions: Elevators and power door operator controls Refer to 4.1.6 and 4.1.14, respectively; card-entry systems and encoded entry/exit systems such as keypads, refer to 4.4.11.

Electrical outlets and other types of devices shall be located no lower than 400 mm (15-3/4 in.). Exception: Where electrical outlets are provided as components of systems furniture, these devices



need not comply with this section provided they are installed in addition to electrical outlets required by the Authority having Jurisdiction.

Faucets and other controls shall be hand-operated or electronically controlled.

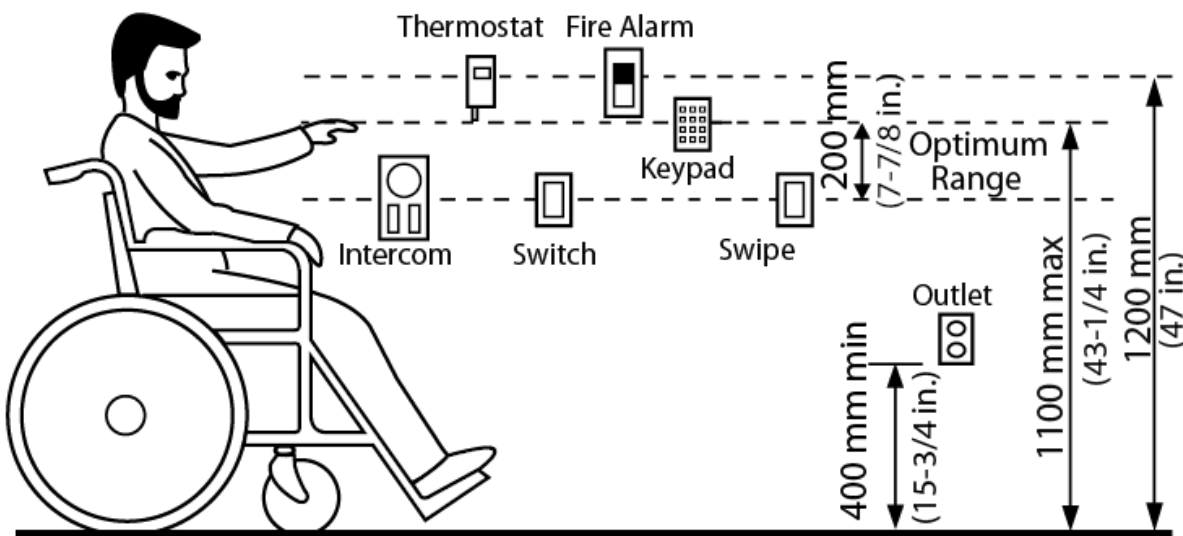
Hand-operated controls and mechanisms shall be operable

- without tight grasping, pinching, or twisting of the wrist;
- with a closed fist (EXCEPTION: manual pull stations); and
- with a force of not more than 22.2 N

Controls and operating mechanisms shall be capable of being illuminated to at least a level of 100 lux (9.2 ft-candles).

Controls and operating mechanisms shall incorporate a pronounced *colour contrast*, to differentiate them from the surrounding environment.

A control that needs to be read or adjusted should be angled in such a way that it is useable from a seated or a standing position.



**Figure 4.4.2.1 Reach Range for Accessible Controls**

Note: Controls and operating mechanisms include, but are not limited to: door handles and locks; window openers and locks; faucets; electrical outlets and switches; thermostats; fire alarm pull stations; button pads and controls on dispensing machines; and, security access card readers.

**RELATED SECTIONS**

4.1.1 Space and Reach Requirements

4.1.3 Protruding and Overhead Objects

4.1.4 Accessible Routes, Paths and Corridors

4.1.6 Doors

- 4.1.7 Gates, Turnstiles and Openings
- 4.1.8 Windows, Glazed Screens and Sidelights
- 4.1.14 Elevators
- 4.1.15 Platform Lifts
- 4.2.2 Toilet Stalls
- 4.2.3 Toilets
- 4.2.4 Lavatories
- 4.2.5 Urinals
- 4.2.6 Washroom Accessories
- 4.2.7 Universal Washrooms
- 4.2.8 Bathtubs
- 4.2.9 Shower Stalls
- 4.3.1 Drinking Fountains
- 4.3.4 Dressing Rooms
- 4.3.5 Offices, Work Areas and Meeting Rooms
- 4.3.9 Storage, Shelving and Display Units
- 4.3.10 Lockers and Baggage Storage
- 4.3.17 Streetscapes
- 4.4.3 Vending and Ticketing Machines
- 4.4.5 Public Telephones
- 4.4.10 Information Systems
- 4.4.11 Card Access, Safety and Security Systems
- 4.4.13 Lighting
- 4.4.15 Texture and Colour

### 4.4.3 VENDING AND TICKETING MACHINES

#### RATIONALE

Space in front of vending machines allows for maneuverability of mobility aids. Seating areas and tables adjacent to vending machines offer convenience and should accommodate the spatial requirements of a wheelchair or scooter. The selection of the machines should include a number of factors. Operating mechanisms should be within reach of children and individuals in wheelchairs. The mechanisms should be operable with one hand and minimal strength, to accommodate a host of disabilities including arthritis, or the need to stabilize oneself with a cane or a handful of bags. Lighting levels and colour contrasts make the machine more accessible to those with a visual impairment.

#### APPLICATION

Vending and ticketing machines shall comply with this section.

#### DESIGN REQUIREMENTS

Vending and ticketing machines shall be located on an *accessible route* in compliance with 4.1.4.

*Clear floor space* in front of vending and ticketing machines shall conform to 4.1.1.

The controls and operating mechanisms on vending and ticketing machines shall comply with 4.4.2.

*Signage* on vending and ticketing machines shall be in highly *contrasting* lettering, at least 13 mm (1/2 in.) high. Ideally, lettering and *signage* shall comply with relevant parts of 4.4.7.

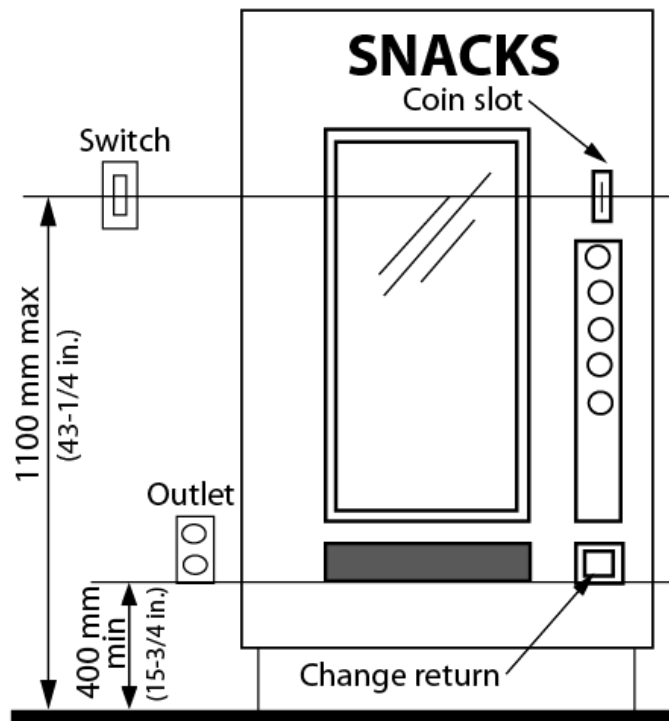


Figure 4.4.3.1 Vending Machine

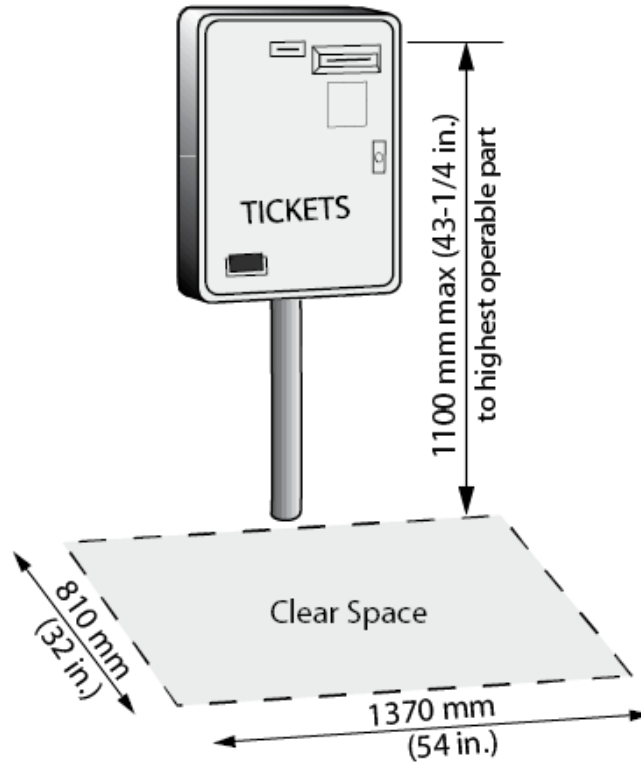


Figure 4.4.3.2 Ticket Dispensing Machine

## RELATED SECTIONS

4.1.1 Space and Reach Requirements

4.1.4 Accessible Routes, Paths and Corridors

4.4.2 Controls and Operating Mechanisms

4.4.15 Texture and Colour

### 4.4.4 VISUAL ALARMS

#### RATIONALE

Visual alarms are essential safety features for individuals who are deaf, deafened or hard of hearing such that they would not hear an audible alarm.

#### APPLICATION

Visual alarms shall comply with this section.

At a minimum, visual alarm appliances shall be provided in *facilities* in each of the following areas: restrooms and any other general usage areas (e.g., *meeting rooms*), hallways, lobbies and any other areas for *common use*.

Visual alarm signal appliances shall be integrated into the *facility* alarm system. If single-station audible alarms are provided, then single-station visual alarms shall be provided.

A signal intended for the public to indicate the operations of a building security system that controls access to a building shall consist of an audible and visual signal.

#### DESIGN REQUIREMENTS

Visual alarm signals shall have the following minimum photometric and location features:

- the lamp shall be a Xenon strobe type or equivalent;
- the colour shall be *clear* or nominal white (i.e. unfiltered or clear filtered white light);
- the maximum pulse duration shall be two-tenths of one second (0.2 sec) with a maximum duty cycle of 40 percent (the pulse duration is defined as the time interval between initial and final points of 10% of maximum signal);
- the intensity shall be a minimum of 75 candela;
- the flash rate shall be a minimum of 1 Hz and a maximum of 3 Hz;
- the appliance shall be placed 2100 mm (82-3/4 in.) above the floor level within the *space* or 150 mm (5-7/8 in.) below the ceiling, whichever is lower;
- in general, no place in any room or *space* required to have a visual signal appliance, shall be more than 15 meters (50 ft.) from the signal (in the horizontal plane). In large rooms and *spaces* exceeding 30 meters (100 ft.) across, without obstructions 2000 mm (78-3/4 in.) above

the finished floor, such as auditoriums, devices may be placed around the perimeter, spaced a maximum of 30 meters (100 ft.) apart, in lieu of suspending appliances from the ceiling;

- no place in common corridors or hallways in which visual alarm signaling appliances are required shall be more than 15 m (50 ft.) from the signal; and
- visual component to smoke alarms to conform to the requirements in 18.5.3. (Light, Colour, and Pulse Characteristics) of NFPA 72 “National Fire Alarm and Signaling Code”.

**RELATED SECTIONS**

4.4.1 Emergency Exits, Fire Evacuation and Areas of Rescue Assistance

**4.4.5 PUBLIC TELEPHONES**

**RATIONALE**

The placement of telephones should address the limited reach of children or persons in a seated position. Longer cords facilitate the use of the phone for someone unable to get close to the phone due to a mobility device. Adjustable volume controls are important for persons who are hard of hearing, as are shelves that could support a TDD device. A fold-down seat is an asset to someone having difficulty standing for extended periods. Telephones projecting from a wall may present a hazard, particularly to persons with a visual *impairment*, if the sides are not configured to be cane-detectable.

**APPLICATION**

Where public pay phones, public closed-circuit phones, or other public telephones are provided, they shall comply with this section to the extent required by Table 4.4.5.

All telephones required to be *accessible* shall be equipped with a volume control. In addition, 25%, but never less than one, of all other public telephones provided shall be equipped with a volume control and shall be dispersed among all types of public telephones, including *closed-circuit telephones*, throughout the *facility*.

*Signage* complying with applicable provisions of 4.4.7 shall be provided.

Where an interior public pay telephone is provided, then at least one interior public *text telephone* (TTY) shall be provided in the *facility* in a *public use* area.

Where an interior public pay telephone is provided in the secured area of a detention or correctional *facility* subject to 4.5.8, then at least one public *text telephone* shall also be provided in at least one secured area. Secured areas are those areas used only by detainees or inmates and security personnel.

**Table 4.4.5** Number of accessible telephones required

| <b>Number of each type of telephone provided on each floor</b> | <b>Number of <i>accessible</i> telephones required for persons who use wheelchairs or scooters</b> | <b>Number of <i>accessible</i> telephones required for persons who are deaf, deafened or hard of hearing</b> |
|--|--|--|
| 1 or more single units   | 1 per floor  | 1 per floor  |
| 1 bank   | 1 per floor  | 1 per floor  |

**Table 4.4.5** Number of accessible telephones required

|                 |   |   |
|-----------------|---|---|
| 2 or more banks | 1 per bank ( <i>Accessible</i> phones may be installed as single units in proximity to (i.e. either visible or with <i>signage</i> ) the bank. At least one public telephone per floor shall meet the requirements for a forward reach telephone. | 1 per bank ( <i>Accessible</i> phones may be installed as single units in proximity to (i.e. either visible or with <i>signage</i> ) the bank. At least one public telephone per floor shall meet the requirements for a forward reach telephone. |
|-----------------|---|---|

Note: A bank consists of two or more adjacent public telephones, often installed as a unit.

## DESIGN REQUIREMENTS

*Accessible* telephones shall be on an *accessible route* complying with 4.1.4.

Telephones, enclosures and related equipment shall comply with 4.1.3.

Telephones shall have push-button controls where service for such equipment is available. The characters on the push buttons shall contrast with their background, which should be non-glare (matte finish), and the buttons themselves should contrast with their background.

The minimum handset cord length of *accessible* telephones shall be 1000 mm (39-3/8 in.).

The minimum illumination level at operating mechanisms, the directory, and shelf of *accessible* telephones shall be 200 lux (18.4 ft.-candles).

*Accessible* telephones shall

- have the maximum height of *operable portions*, including the coin slot, 1110 mm (43-1/4 in.) above the floor;
- have *operable portions* within the reach ranges specified in 4.1.1;
- have a *clear floor space* of not less than 810 mm (32 in.) wide centred on the telephone, by 1370 mm (54 in.) deep in front of the telephone, and no obstruction within 250 mm (9-13/16 in.) above the surface;
- have a top surface of a section of the telephone shelf or counter located not less than 775 mm and not more than 875 mm (34-1/2 in.) from the finished floor, and have a knee space not less than 740 mm (29-1/8 in.) high; and
- have the top surface of a section of shelf or counter serving at least 1 telephone be 775 mm (31 in.) to 865 mm (34 in.).

*Text telephones* (TTY's) used with a pay telephone shall be permanently affixed within, or adjacent to, the telephone enclosure. If an acoustic coupler is used, the telephone cord shall be sufficiently long to allow connection of the *text telephone* (TTY) and the telephone receiver.

Where telephones are for use by persons who are deaf, deafened, hard of hearing or speech-impaired, the telephones shall

## Exhibit A

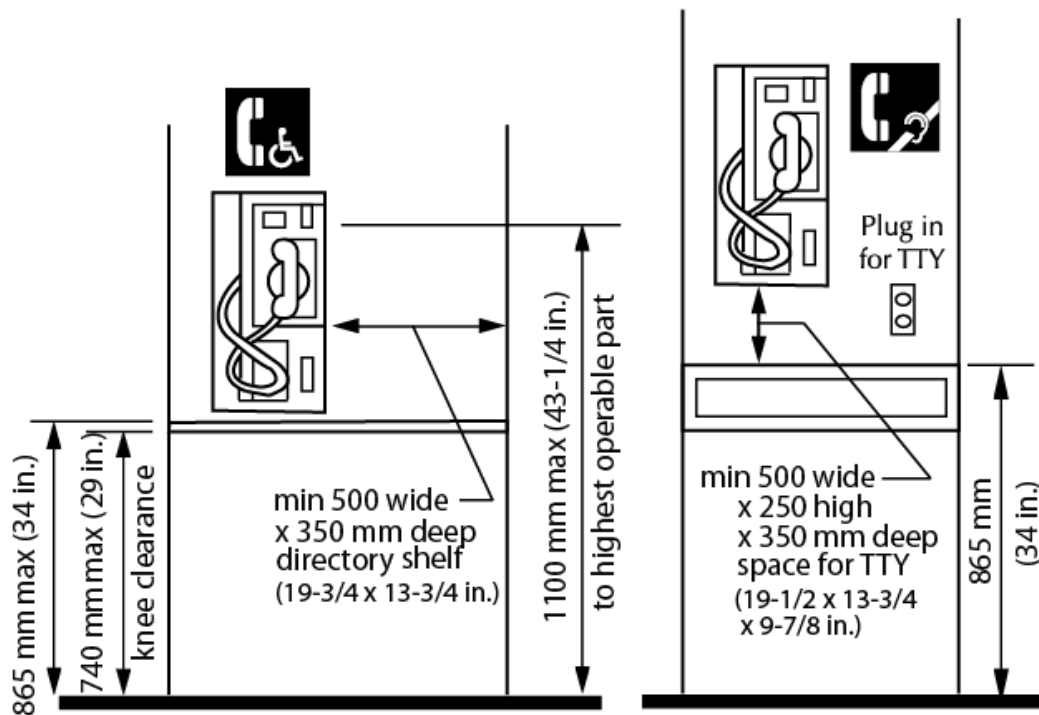
- be a separate telephone from those provided for persons who use wheelchairs or scooters;
- comply with CSA Standard T515;
- be equipped with an electrical outlet, within or adjacent to the telephone enclosure (TTY only);
- have a separate flat telephone directory shelf (TTY only) at least 500 mm (19-3/4 in.) wide and 350 mm (13-3/4 in.) deep, with at least 250 (9-7/8 in.) *clear space* above the shelf; and
- be equipped with a handset capable of being placed flush on the surface of the shelf (TTY only)

*Text telephones (TTY's)* used with a pay telephone shall be permanently affixed within, or adjacent to, the telephone enclosure. If an acoustic coupler is used, the telephone cord shall be sufficiently long to allow connection of the *text telephone (TTY)* and the telephone receiver.

As new phone technology is developed for persons who are deaf or hard of hearing, installation of these devices should be strongly considered (i.e. video relay).

Accessible telephones shall be identified by the appropriate symbol of accessibility for mobility impaired persons and/or persons who are deaf or hard of hearing.

When directional signs for telephones are installed, they shall include the appropriate access symbols.



**Figure 4.4.5.1-2** Accessible Telephone for Persons who use Wheelchairs or Scooters and Accessible Telephone for Persons who are Deaf, Deafened, Hard of Hearing, or Speech-Impaired.



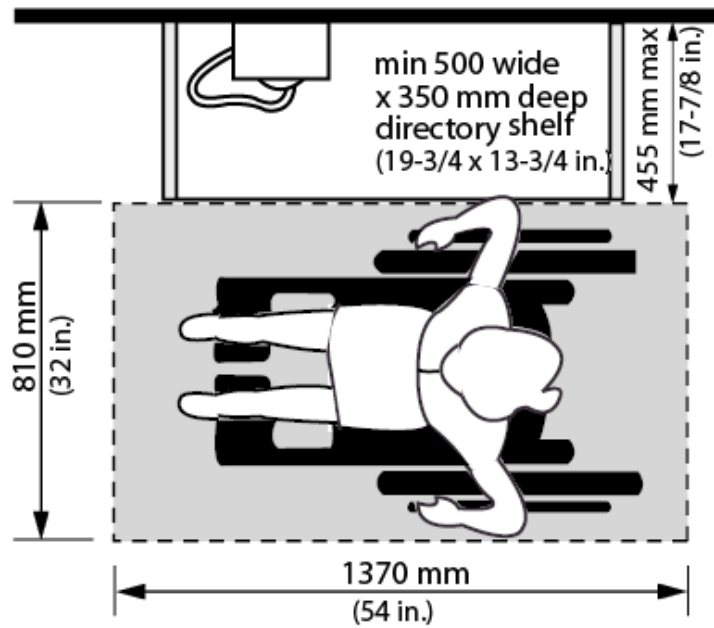


Figure 4.4.5.3 Parallel Approach to a Public Telephone

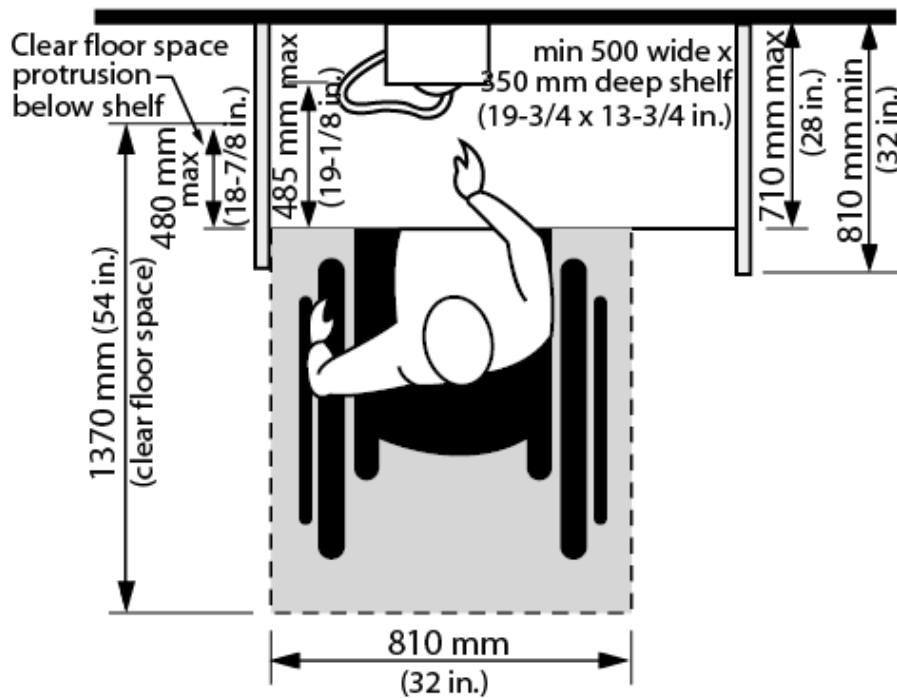


Figure 4.4.5.4 Forward Approach to a Public Telephone

**RELATED SECTIONS**

4.1.1 Space and Reach Requirements

4.1.3 Protruding and Overhead Objects

4.1.4 Accessible Routes, Paths and Corridors

4.4.2 Controls and Operating Mechanisms

4.4.7 Signage

4.4.13 Lighting

4.4.15 Texture and Colour

## **4.4.6 ASSISTIVE LISTENING SYSTEMS**

### **RATIONALE**

The provision of assistive listening devices is important for the range of individuals who may have difficulty hearing.

Adequate and controllable lighting is required for persons who lip-read, or those who require increased task lighting, due to a visual *impairment*.

### **APPLICATION**

Assistive listening systems shall comply with this section.

This section applies to *assembly areas* where audible communication is integral to the use of the *space* (e.g., concert theatres, *meeting rooms*, classrooms, auditoria, etc.).

Such *assembly areas* shall have a permanently installed listening system in compliance with this section where:

- they accommodate at least 50 persons or where they have audio amplification systems or where greater than 100 sq.m. (1080 sq.ft.) in floor area; and
- they have fixed seating.

For other *assembly areas*, a permanently installed listening system or an adequate number of electrical outlets or other supplementary wiring necessary to support a portable assistive listening system shall be provided. The minimum number of receivers to be provided shall be equal to 4% of the total number of seats, but no less than two.

### **DESIGN REQUIREMENTS**

*Signage* complying with applicable provisions of 4.4.7 shall be installed to notify patrons of the availability of a listening system.

Induction loops, infrared systems and FM radio frequency systems shall be considered acceptable types of assistive listening systems for persons who are hard of hearing.

Where an induction loop system is installed, dimmer switches and other controls that incorporate transformer coils shall be located so as not to interfere with the audio induction loop.

Where infrared assistive listening devices are used, overhead incandescent lights shall be located so as not to cancel out the infrared signal at the receiver.

Where an FM loop system or other assistive listening devices are available in public *facilities* or meeting areas, portable headsets that are compatible with personal hearing aids shall be made available.

Where an induction loop system is utilized, at least half the seating area shall be encompassed.

Where the listening system provided serves individual fixed seats, such seats shall be located within a 15 m (50-ft.) viewing distance of the stage or playing area and shall have a complete view of the stage or playing area.

## **RELATED SECTIONS**

4.4.7 Signage

4.4.13 Lighting

4.4.16 Acoustics

### **4.4.7 SIGNAGE**

#### **RATIONALE**

Signage should be simple, uncluttered and incorporate plain language. The use of graphic symbols is helpful for individuals such as children; those with a limited literacy level; or those who speak a different language.

Sharp *contrasts* in colour make signage easier for anyone to read, particularly someone with a visual *impairment*. The intent of the symbol must be evident, culturally universal and not counterintuitive. To enhance readability, raised *tactile* lettering should incorporate edges that are slightly smoothed.

#### **APPLICATION**

*Signage* shall comply with this section..

Signs that designate permanent rooms or *spaces* shall be wall-mounted and include *tactile* characters and numbers. *Tactile* markings shall also supplement the text of

- regulatory signs, such as prohibition and mandatory signs;
- warning signs, such as caution and danger signs; and
- identification signs, such as rooms titles, names or numbers.

Signs that provide direction to, or information about, functional *spaces*, shall comply with this section. Exception: *Facility* directories, menus and all other signs that are temporary are not required to comply.

*Elements* and *spaces* of *accessible facilities* that shall be identified by the International Symbol of Accessibility are

- parking *signage*, designated as reserved for individuals with disabilities;
- *accessible* passenger loading zones;
- accessible ramps located in a barrier-free *path of travel* serving a building entrance;
- *accessible entrances* when not all are *accessible* (inaccessible *entrances* shall have directional *signage* to indicate the route to the nearest *accessible entrance*);
- *accessible* toilet and bathing *facilities*, including single-use portable units, when not all are *accessible* (sign shall indicate the location of a washroom required to be barrier-free);
- *accessible* telephones;
- *accessible* elevators and other elevating devices;
- *accessible means of egress*; and
- areas of *rescue assistance*.

*Elements and spaces of accessible facilities* that shall be identified by the Dynamic Symbol of Accessibility are

- pavement markings in all accessible parking *spaces*, designated as reserved for individuals with disabilities;
- *accessible* business, mercantile and civic checkout aisles
- *accessible* dressing rooms
- *accessible lockers and bathing storage areas*

Audible signs (infrared and digital) that are readable by persons with a visual impairment using a receiving device may be the sole orientation aid across open *spaces*. Consideration should be given to including wire drops for future installation.

**Table 4.4.7** Character height on signs

| Minimum character height, mm | Maximum viewing distance, mm |
|------------------------------|------------------------------|
| 200 (7-7/8 in.)              | 6000 (19 ft. 8 in.)          |
| 150 (5-7/8 in.)              | 4600 (15 ft. 0 in.)          |
| 100 (3-15/16 in.)            | 2500 (8 ft. 2-1/2 in.)       |
| 75 (2-15/16 in.)             | 2300 (7 ft. 6-1/2 in.)       |
| 50 (2 in.)                   | 1500 (4 ft. 11 in.)          |
| 25 (1 in.)                   | 750 (2 ft. 5-1/2 in.)        |

**DESIGN REQUIREMENTS**

Letters and numbers on signs shall

- be sans serif;\* (i.e. Helvetica, Univers 55, Verdana, Arial);\*
- have Arabic numbers;
- have a width-to-height ratio between 3:5 and 1:1; and
- have a stroke-width-to-height ratio between 1:5 and 1:10.

Character height dimensions for viewing distance shall comply with Table 4.4.7. Minimum character height may be reduced where closer viewing distance is possible, for regulatory signage or for signs not located on an accessible route.

Signage should use a mix of upper and lower case letters.

Characters, symbols and backgrounds of signs shall have a high tonal eggshell, matte or other glare-free finish.

Characters and symbols shall contrast with their background; either light characters on a dark background or dark characters on a light background.

Where signs are required to be *tactile*, letters and numerals shall be

- raised at least 0.8 mm (1/32 in.), not sharply edged;
- be between 16 mm (5/8 in.) and 50 mm (2 in.) high; and
- be sans serif\*, accompanied by Grade 2 Braille.



**Figure 4.4.7** Sample of Serif and Sans-Serif Fonts

Pictograms shall be accompanied by an equivalent visual and *tactile* verbal description, placed directly below the pictogram. The border dimension of the pictogram shall be 150 mm (6 in.) minimum in height.

Where permanent identification is provided for rooms and *spaces*, signs shall be installed on the wall adjacent to the latch side of the door, located with their centre line a minimum 1400 mm (55 in.) and maximum 1500 mm (59 in.) above the finished floor, with tactile elements located 1400 mm (55 in.) to 1500 mm (59 in.). Where there is no wall *space* on the latch side of the door, including at double-leaf doors, signs shall be placed on the nearest adjacent wall.

The minimum level of illumination on signs shall be 200 lux (18.4 ft.-candles).

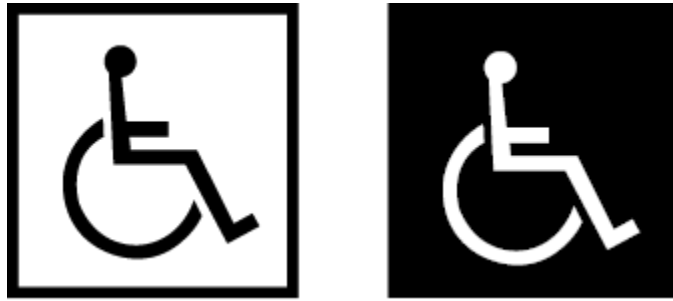


Figure 4.4.7.1 Colour contrast on Signs



Figure 4.4.7.2a-e Pictograms (Note: Must incorporate equivalent verbal description.)

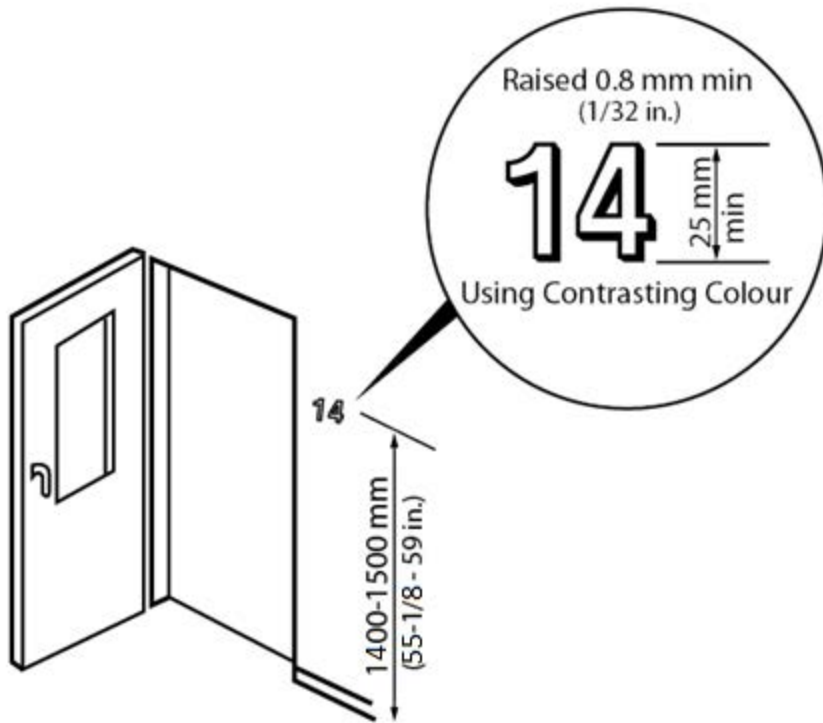


Figure 4.4.7.3 Tactile Lettering



Grid for reference only

Figure 4.4.7.4 International Symbol of Access

**RELATED SECTIONS**

- 4.1.3 Protruding and Overhead Objects
- 4.1.4 Accessible Routes, Paths and Corridors
- 4.1.5 Entrances
- 4.1.6 Doors
- 4.1.7 Gates, Turnstiles and Openings
- 4.1.9 Ramps

4.1.14 Elevators

4.1.15 Platform Lifts

4.2.1 Toilet Facilities

4.2.7 Universal Washrooms

4.3.2 Viewing Positions

4.3.4 Dressing Rooms

4.3.12 Parking

4.3.13 Passenger-Loading Zones

4.4.1 Emergency Exits, Fire Evacuation and Areas of Rescue Assistance

4.4.5 Public Telephones

4.4.13 Lighting

4.4.15 Texture and Colour

#### **4.4.8 DETECTABLE WARNING SURFACES**

##### **RATIONALE**

*Detectable warning surfaces* (also known as Tactile Ground Indicators (TGI) or Tactile Warning Surface Indicators (TWSI)) provide important navigational cues for persons with a visual impairment. These surfaces alert all pedestrians to potential hazards, such as crosswalks or stairs. Suitable surfaces include a change in texture and high *colour contrast* but should not present a tripping hazard.

*Detectable warning surfaces* should be used consistently throughout a *facility*.

##### **APPLICATION**

*Detectable warning surfaces* at interior and exterior *walkways, curb ramps*, stairs, elevated platforms and potential hazards shall comply with this section.

##### **DESIGN REQUIREMENTS**

All textured surfaces used as *detectable warning surfaces* shall be clearly detectable by walking upon as being different from the surrounding surface. (Refer also to 4.4.15). Note: Applying a paint finish to a concrete surface does not provide appropriate detectability.

*Detectable warning surfaces* shall contrast visually with adjoining surfaces, being either light on dark or dark on light.

*Detectable warning surfaces* at interior stairs shall



## Exhibit A

- be provided at the top of the stairs and at landings with entry points; (Refer to Figure 4.4.8.1). (
- be slip resistant;
- extend the full width of the stair for a depth of at least 920 mm (36 in.) commencing one tread depth back from the stair;
- contrast visually with adjoining surfaces; and
- not be more than 3 mm (1/8 in.) above or below the surrounding surface.

Refer also to section 4.1.11.

*Detectable warning* surfaces at exterior *curb ramps*, *depressed curbs*, exterior stairs and elevated platforms shall

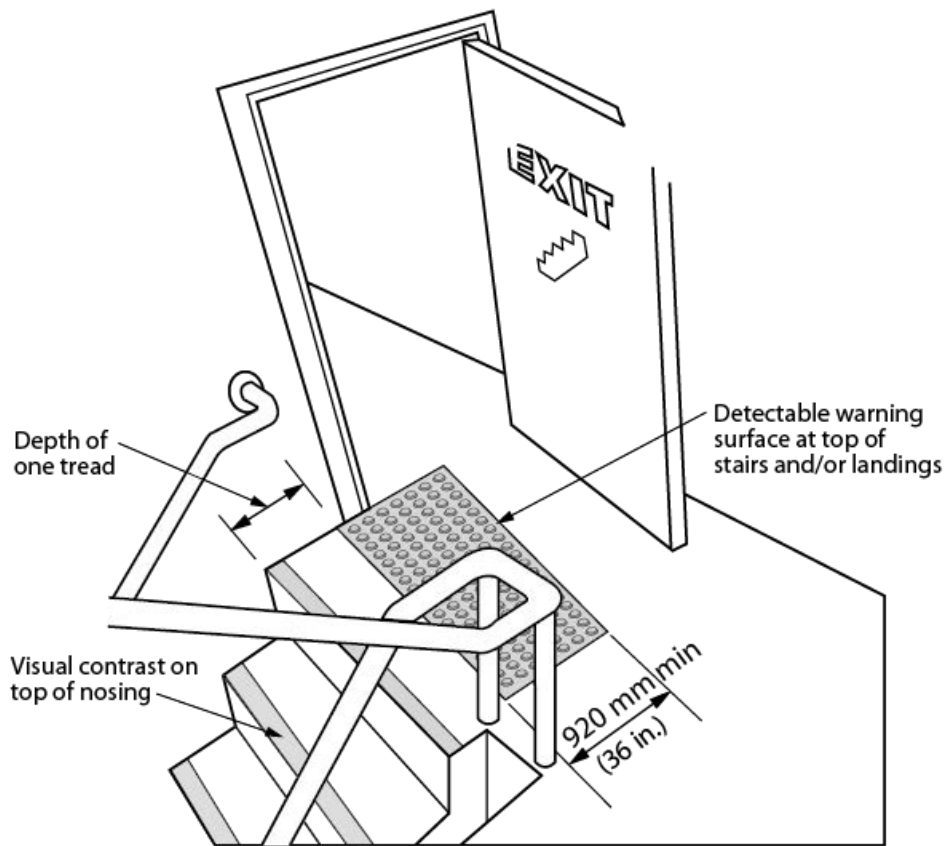
- be composed of truncated domes with a height of 4.5 - 5.5 mm (0.18 to 0.22 in.);
- have top and bottom dimensions as shown in Table 4.4.8;
- be arranged in a regular pattern with spacing as shown in Table 4.4.8.
- be slip-resistant; and
- contrast visually with adjoining surfaces.

If a *walkway* crosses or joins a *vehicular way* and the walking surfaces are not separated by curbs, railings or other *elements* between the pedestrian areas and vehicular areas, the boundary between the areas shall be defined by a continuous *detectable warning surface*, which is minimum 920 mm (36 in.) wide. Refer also to section 4.1.10.

**Table 4.4.8** Size and spacing of flat-topped domes or cones

| <b>Top diameter of flat-topped domes or cones</b> | <b>Spacing</b>         |
|---|------------------------|
| 12 (0.5)  | 42 – 61mm (1.7-2.4)    |
| 15 (0.6)  | 45 – 63 mm (1.8 - 2.5) |
| 18 (0.7)  | 48 - 65 mm (1.9 - 2.6) |
| 20 (0.8)  | 50 - 68 mm (2.0 - 2.7) |
| 25 (1.0)  | 55 - 70 mm (2.2 - 2.8) |

\*Note: Bottom diameter of flat-topped domes or cones 10+/- 1 greater than the top diameter.



**Figure 4.4.8.1** Detectable Warning Surfaces at Stairs

**RELATED SECTIONS**

- 4.1.3 Protruding and Overhead Objects
- 4.1.4 Accessible Routes, Paths and Corridors
- 4.1.9 Ramps
- 4.1.10 Curb Ramps
- 4.1.11 Stairs
- 4.1.12 Escalators
- 4.3.1 Drinking Fountains
- 4.3.3 Elevated Platforms
- 4.3.12 Parking
- 4.3.13 Passenger-Loading Zones
- 4.4.15 Texture and Colour

**4.4.9 PUBLIC ADDRESS SYSTEMS****RATIONALE**

Public address systems should be designed to best accommodate all users, especially those that may be hard of hearing. They should be easy to hear above the ambient background noise of the environment and there should be no distortion or feedback. Background noise should be minimized.

Visual equivalents should be made available for individuals with a hearing *impairment* who may not hear an audible public address system.

**APPLICATION**

Public address systems shall comply with this section.

**DESIGN REQUIREMENTS**

Public address speakers shall be mounted above head level, and provide effective sound coverage in required areas, such as corridors, assembly and *meeting room* areas, recreational and entertainment *facilities*, educational *facilities*, and *common use* areas in institutional settings.

Public address systems shall be zoned so that information can be directed to key locations only, minimizing background noise in other areas.

Where public address systems are used to broadcast background music, the music shall not be broadcast continuously or throughout the entire *facility*.

All-point call systems shall only be utilized for fire and emergency information.

Paging systems for staff and other key persons shall be discreet and low volume, and sound only at those devices or locations where such persons might expect to be located.

## **RELATED SECTIONS**

4.4.1 Emergency Exits, Fire Evacuation and Areas of Rescue Assistance

4.4.16 Acoustics

## **4.4.10 INFORMATION SYSTEMS**

### **RATIONALE**

Information should be *accessible* to all facility users. Where universally *accessible* formats are technically not feasible, alternate formats should be available. Video display terminals may present particular difficulties for persons with a visual *impairment*. Alternate technology or audio interfaces are required.

To ensure that a person using a wheelchair or scooter can access an information terminal, consideration should be given to the lower vantage point and reach ranges of all information systems provided.

### **APPLICATION**

Information systems, such as display kiosks, video display terminals, parks and *recreational trails* mapping, and interpretive/informational panels shall comply with this section.

### **DESIGN REQUIREMENTS**

Where information is provided by video display terminals to the general public, clients or customers, the same information shall be provided in an alternative format, such as audio, Braille and large-text print. The minimum font size for large-text print shall be 16 point. Refer to the Canadian National Institute of the Blind "Clear Print Guidelines" for further detail.

Information systems designed for direct access by the public, such as touch-screen video display, keyboard or keypad access, shall be mounted at a height suitable for use by a person using a wheelchair or scooter (Refer to 4.4.2).

Essential print information shall be printed in large text on a highly *contrasting* background colour, and should also be available in other formats, such as audiotape and large-text print.

Push buttons or other controls for accessing public information systems should be clearly identifiable by colour and/or tone from the background colour, and should include raised numbers, numerals or symbols for easy identification by persons with a visual *impairment*.

*Tactile* identification shall comply with 4.4.15.

Exhibits that include important artifacts, labels and graphics, shall be placed 1000 - 1200 mm (39-3/8 - 47 in.) from the floor.

Labels and descriptive signage shall be inclined from horizontal for easier reading.

## Exhibit A

Inclined informational/interpretive panels that cannot be read from 750 mm (29-1/2 in.) away shall have at least 660 mm (26 in.) of knee clearance and at least 470 mm (18 in.) deep. If displays are intended for viewing from 750 mm (29-1/2 in.) or further, less clearance is permitted to a minimum height of 220 mm (9 in.) for toe kick clearance. The top of the panel shall be not more than 1220 mm - 1380 mm (48 in. - 54 in.) high.

Vertical informational/interpretive panels shall have text located no higher than 1750 mm (69 in.). Text shall not be lower than 750 mm (29-1/2 in.) above the floor.

No part of the sign shall encroach on the *path of travel*. If encroachment is unavoidable, cane-detection through colour and texture change shall be provided on the ground.

A minimum 1500 mm x 1500 mm (60 in. x 60 in.) clear space directly in front of the sign as well as the clearances needed around such, is required for its approach and use.

Automated banking machines shall comply with Canadian Standards Association B651.1 Barrier-Free Design for Automated Banking Machines (latest edition).

Self-service interactive devices shall comply with Canadian Standards Association B651.2 Accessible Design for Self-Service Interactive Devices (latest edition).

*Signage* and other media for *recreational trails* and footbridges shall conform to 4.5.2.

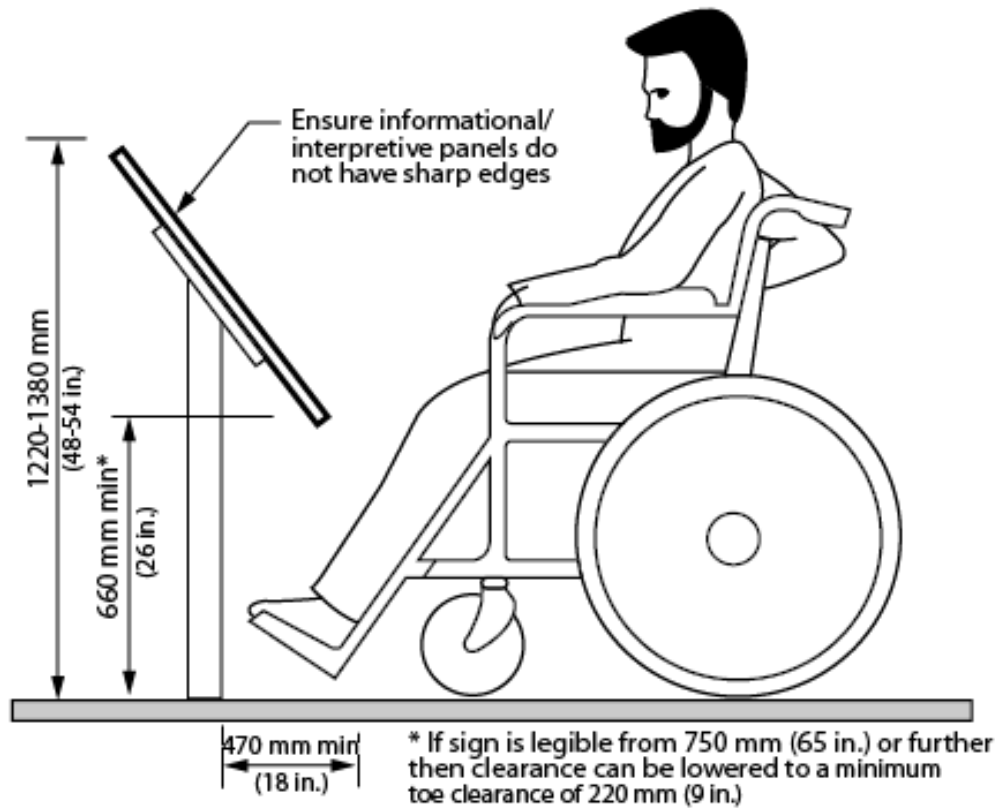


Figure 4.4.10.1 Critical Dimensions for Information Systems and Displays

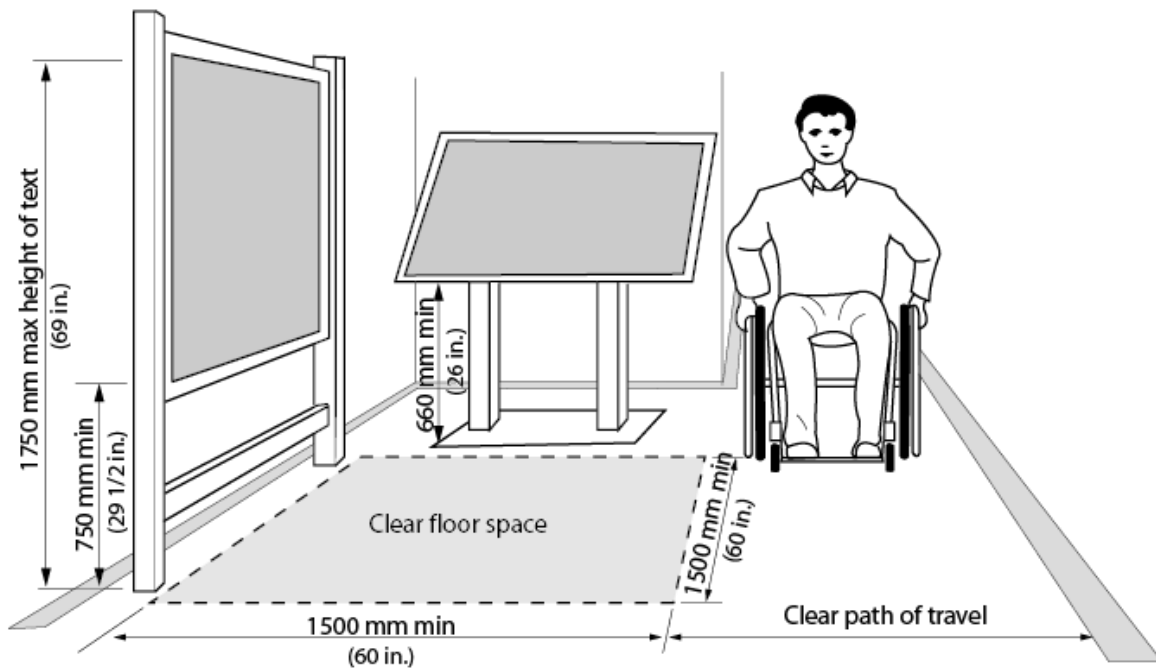


Figure 4.4.10.2 Clear Space and Dimensions around Information Systems

## RELATED SECTIONS

### 4.4.2 Controls and Operating Mechanisms

#### 4.4.15 Texture and Colour

## 4.4.11 CARD ACCESS, SAFETY AND SECURITY SYSTEMS

### RATIONALE

In many cases, persons such as seniors and persons with *disabilities* may be considered to have a higher degree of vulnerability and therefore seek more reassurance and inherent security. Items such as adequate lighting and *accessible* signaling devices promote this security.

Emergency signaling devices are important in Universal Washrooms where the potential for a fall is increased and an individual may be alone.

Where card-access systems are selected as a means of entry to particular *facilities* or *spaces*, the systems and components selected should be suitable for use by persons with varying abilities, including persons with reduced manual dexterity, poor vision or difficulty with reaching. The use of heat-sensing activation buttons should be avoided, as they are indiscernible to a person who is blind.

### APPLICATION

Card-access, safety and security systems shall comply with this section.

Where signals intended for the public to indicate the operation of a building security system are provided, they shall consist of both audible alarms and visual signals.

### DESIGN REQUIREMENTS

Adequate lighting shall be provided continuously along public walkways, steps and *ramps* that are actively used at all times of year and/or where staff and public parking is provided.

Where public telephones are installed, an *accessible* public telephone complying with 4.4.5 shall be located at, or close to an *accessible entrance*, for the use of persons requiring assistance.

Where *accessible* Universal Washrooms are provided in assembly *buildings*, such as recreation centres, the washroom shall incorporate an emergency call system linked to a central monitoring location (e.g., office or switchboard). This system shall consist of audible and visual signal devices inside and outside of the washroom that are activated by a control device inside the washroom typically in reach of the toilet. An emergency sign shall be posted above the emergency button in letters at least 25 mm (1 in.) high with a 5 mm (3/16 in.) stroke that contains the words IN THE EVENT OF AN EMERGENCY PUSH EMERGENCY BUTTON AND AUDIBLE AND VISUAL SIGNAL WILL ACTIVATE.

Card-entry systems shall

- be wall-mounted, no higher than 1060 mm (42 in.) above the floor or ground, adjacent to the door and free of the door swing;

- be *colour contrasted* from the surface on which they are mounted;
- incorporate a card slot that is illuminated or *colour contrasted* from the mounting plate; and
- use cards that incorporate a distinctive colour, texture or raised graphic/lettering on one side.

Encoded-entry/exit systems, such as keypads, shall

- be wall-mounted, no higher than 1060 mm (42 in.) above the floor or ground, adjacent to the door and free of the door swing; and
- incorporate buttons that
  - are raised;
  - are mounted on a clearly differentiated coloured background; and
  - include raised numerals or letters in a constant array

## **RELATED SECTIONS**

4.1.1 Space and Reach Requirements

4.1.4 Accessible Routes, Paths and Corridors

4.1.5 Entrances

4.1.6 Doors

4.1.14 Elevators

4.1.15 Platform Lifts

4.2.7 Universal Washrooms

4.3.5 Offices, Work Areas and Meeting Rooms

4.4.2 Controls and Operating Mechanisms

4.4.13 Lighting

4.4.15 Texture and Colour

## **4.4.12 GLARE AND LIGHT SOURCES**

### **RATIONALE**

Direct or reflected glare from floors, walls or work surfaces is uncomfortable for all users and a barrier to persons with reduced vision. Therefore, every attempt should be made to select light sources, materials and finishes which do not add to the problem, and to ensure that natural daylight is controllable.

The strategic use of lighting is valuable to all individuals, and especially important for individuals with some form of visual *impairment*. In addition, offering a variety of task lighting at work areas is beneficial to all.



**APPLICATION**

Systems used to control glare and excessive reflected light shall comply with this section.

**DESIGN REQUIREMENTS**

Extensive high gloss floor and wall finishes are not acceptable, but high-gloss materials may be incorporated into floor and wall finish details, as long as they do not result in large reflective surfaces.

Monolithic floor surfaces, such as stone, granite, marble or terrazzo, shall have a matte or honed finish, to minimize reflected glare.

Finishes such as vinyl, other composition materials, quarry tile, glazed tile or mosaics, used on horizontal surfaces, such as floors and work surfaces, shall be in matte or satin finishes.

Finishes such as paint, vinyl wall coverings, stone, marble, wood, metals, plastic laminate, etc., used on vertical surfaces, such as walls and columns, shall have matte or satin finishes.

Curtains, blinds or other sun-screening systems shall be provided at windows and other places where direct sunlight can adversely affect the level of lighting and/or reflected glare.

Light fixtures shall be selected with diffusers, lenses or recessed light sources, so that no glare is created.

Where surface-mounted fluorescent ceiling fixtures are mounted below 2440 mm (96 in.), they shall have darkened sides (i.e., not wrap-around lenses) and be positioned perpendicular to the dominant direction of travel, or used in valance-type lighting along the perimeter of a *space*, resulting in indirect lighting.

The location of special features and key orientation *elements* shall be enhanced through the use of supplementary lighting. Such lighting shall have upward or downward components only.

**RELATED SECTIONS**

4.1.2 Ground and Floor Surfaces

4.1.4 Accessible Routes, Paths and Corridors

4.1.5 Entrances

4.1.8 Windows, Glazed Screens and Sidelights

4.1.9 Ramps

4.1.10 Curb Ramps

4.1.11 Stairs

4.1.13 Escalators

4.1.14 Elevators

4.1.15 Platform Lifts

## 4.2.1 Toilet Facilities

## 4.3.8 Information, Reception and Service Counters

## 4.4.13 Lighting

**4.4.13 LIGHTING****RATIONALE**

Artificial lighting and natural light sources should provide comfortable, evenly distributed light at all working areas, in all circulation routes and in all areas of potential hazard. Also, outdoor lighting should be provided at *entrances*, along frequently used access routes and at frequently used outdoor *amenities*.

**APPLICATION**

Exterior and interior lighting systems shall comply with this section.

**DESIGN REQUIREMENTS****EXTERIOR LIGHTING**

Exterior lighting shall be in compliance with Illuminating Engineering Society of North America Standards (IESNA) in all public thoroughfares, and at all pedestrian routes, to provide safe access for persons with disabilities from sidewalks, bus stops and parking areas to nearby *facilities* and *site amenities*.

Pedestrian *entrances*, of facilities that are intended to be open after dark, shall have a minimum Average Maintained light level of 50 lux (5 ft-candles) consistently over the *entrance* area, measured at the ground.

Light levels are described as Average Maintained. Light distribution, or photo metrics, of a lighting design include brighter areas and darker areas, depending on the distance from the light source, that when averaged, will provide the user with an overall light level experience. The evenness, or range, of light to dark areas is measured as a ratio. For pathways, for example, the IESNA recommends 10:1 as a minimum evenness. In some applications 5:1 to 3:1, for higher use areas, should be considered.

Lower use pedestrian routes, including walkways, paths, stairs and ramps, when lit, shall have a minimum Average Maintained light level of 5 lux (0.5 ft- candles) consistently over the route, measured at the ground. Over moderately used pedestrian routes, when lit, the Average Maintained light level shall be within a range of 10-25 lux (1.0-2.5 ft- candles). Frequently used pedestrian routes, when lit, shall have a minimum Average Maintained light level of 30 lux (3 ft- candles).

At designated parking *spaces*, in lit parking lots, including *accessible spaces* and limited mobility/caregivers *spaces*, a minimum Average Maintained light level of 30 lux (3 ft-candles) is required consistently over each of these parking *spaces*, measured at the ground.

Lighting levels at passenger drop-off areas, when lit, shall have a minimum Average Maintained light level of 30 lux (3 ft-candles) consistently over the drop-off area, measured at the ground.

When part of a lit pedestrian route, at frequently used steps and stairs, lighting shall be located at or beside the steps or stairs, to clearly define the treads, risers and nosings.

All lighting shall

- provide a good colour spectrum; and
- be evenly distributed to minimize cast shadows.

Supplementary lighting shall be provided to highlight key *signage* and orientation landmarks.

Low/ground-level lighting (such as bollards) shall be high enough to clear normal snow accumulation.

Lighting fixtures shall comply with the relevant parts of 4.1.3 and 4.3.17.

### INTERIOR LIGHTING

Light sources and fixtures shall be selected to minimize direct glare or indirect glare on nearby reflective surfaces.

Light sources shall provide as full a spectrum of light as possible, as an aid to edge and colour definition.

Lighting shall be configured to create an even distribution at floor level and to minimize pools of light and areas of shadow.

The leading edge of stairs, steps, *ramps* or escalators shall be evenly lit to minimize tripping hazards.

Lighting levels in elevator lobbies shall be similar to the lighting levels in elevator cabs, to minimize tripping hazards, and in no case shall be less than 200 lux (20 ft.-candles).

Lighting levels in washrooms and dressing rooms shall be evenly distributed and no less than 200 lux (20 ft.-candles).

Lighting levels in office areas shall be evenly distributed and no less than 300 lux (30 ft-candles).

Emergency lighting over stairs and *ramps*, in an exit or *path of travel*, shall be at least 100 lux (10 ft.-candles), generally at the walking surface, and in no place less than 50 lux (5 ft-candles).

Lighting over directional or informational *signage*, or highlighting other orientation features, at public telephones, information or service counters, and card or keypad security systems, shall be no less than 200 lux (20 ft-candles) measured at the working surface.

Lighting in *meeting rooms* and *assembly areas* shall be evenly distributed, and shall be capable of being adjusted (e.g., dimmers).

Lighting at lecterns, podiums/ platforms or other speaker locations shall be capable of being enhanced, even when other lighting is dimmed, to permit ease of lip-reading and/or viewing of the hand actions of a nearby ASL translator for persons who are deaf.

**RELATED SECTIONS**

- 4.1.3 Protruding and Overhead Objects
- 4.1.4 Accessible Routes, Paths and Corridors
- 4.1.5 Entrances
- 4.1.9 Ramps
- 4.1.10 Curb Ramps
- 4.1.11 Stairs
- 4.1.12 Escalators
- 4.1.14 Elevators
- 4.1.15 Platform Lifts
- 4.2.1 Toilet Facilities
- 4.3.1 Drinking Fountains
- 4.3.3 Elevated Platforms
- 4.3.4 Dressing Rooms
- 4.3.5 Office, Work Areas and Meeting Rooms
- 4.3.8 Information, Reception and Service Counters
- 4.3.17 Streetscapes
- 4.4.2 Controls and Operating Mechanisms
- 4.4.5 Public Telephones
- 4.4.7 Signage
- 4.4.12 Glare and Light Sources

**4.4.14 MATERIALS AND FINISHES**

**RATIONALE**

The selection of flooring materials can be critical to the safe and easy movement of persons using all kinds of mobility aids, as well as persons with low vision.

Floor finishes, such as carpet, should be selected and installed so that persons using wheelchairs and walkers or other mobility aids can easily travel over them without using undue energy or tripping.

Finishes that are slip-resistant and not highly reflective promote safe travel.

## **APPLICATION**

Exterior and interior materials and finishes shall comply with this section.

## **DESIGN REQUIREMENTS**

### **EXTERIOR FINISH MATERIALS**

Suitable materials for exterior path of travel should be firm and stable and may include materials such as: concrete, asphalt, macadam, compacted gravel screenings, engineered wood fibre, precast paving or unit paving, interlocking brick and patio stones or decking. Other surfaces may be suitable as new innovative materials become available. Where wooden planks are used for boardwalks, they shall be laid perpendicular to the *path of travel*. Such materials shall

- have joints that are no greater than 6 mm (1/4 in.) wide, with variations in level of no more than 3 mm (1/8 in.); and
- be laid to drain.

Where possible, gratings and grills shall be located to one side of the pedestrian walkways, so as not to impede the *accessible route*. Where this is not possible, the bars of the grating or grill shall be located perpendicular to the dominant *path of travel*, with openings of no greater than 13 mm (1/2 in.).

Steps shall be finished with a non-slip material and incorporate highly *contrasted* nosings.

*Ramp* surfaces shall be firm and non-slip.

Handrails and *guards* shall be continuous, smooth and well maintained.

### **INTERIOR MATERIALS AND FINISHES**

Carpet shall be of low-level loop construction, 10 or 12-gauge non-static fibre, directly glued to the subfloor.

Where hard, monolithic materials are selected, they shall be non-slip and non-glare, complying with 4.4.12.

Where floor tiles, bricks or pavers are used, joints should be no wider than 6 mm (1/4 in.) and should be flush.

Wall surfaces in corridors shall be non-abrasive from the floor level to a minimum of 2000 mm (78-3/4 in.) above the finished floor.

## **RELATED SECTIONS**

4.1.2 Ground and Floor Surfaces

4.1.4 Accessible Routes, Paths and Corridors

4.1.5 Entrances

4.1.9 Ramps

4.1.10 Curb Ramps

4.1.11 Stairs

4.1.13 Escalators

4.1.14 Elevators

4.1.15 Platform Lifts

4.2.1 Toilet Facilities

4.3.4 Dressing Rooms

4.3.5 Offices, Work Areas and Meeting Rooms

4.4.12 Glare and Light Sources

## **4.4.15 TEXTURE AND COLOUR**

### **RATIONALE**

The ability of an individual with a visual *impairment* to navigate an environment can be enhanced through the strategic use of colour and texture.

Caution is recommended in the selection of heavy or distinct patterns on walls or floors, since these can add visual confusion to settings for persons with low vision. Simple, repetitive, non-directional patterns that feature monochromatic or low-*colour contrast* are preferred. Changes in material or texture should not necessitate a threshold.

### **APPLICATION**

Textural and colour systems shall be used to enhance accessibility and shall comply with this section.

### **DESIGN REQUIREMENTS**

Exterior colour schemes shall incorporate a pronounced *colour contrast*, to differentiate boundaries of objects, distinguish objects from their background, and to generally enhance spatial orientation.

Generally, for seniors and persons with low vision, colours in the warm end of the spectrum (yellow, orange, bright red, etc.) are easier to recognize than those at the cool end of the spectrum.

Signs shall incorporate pronounced glare-free *colour contrast*. A minimum contrast of 70% light reflectance is required. For signs, the most visible colours are white or yellow on a black, charcoal or other dark background, such as brown, dark blue, dark green or purple. Black lettering on white is also acceptable, although less readable than the reverse. Unacceptable background colours are light grey and pastel colours. Signage should avoid using the colour combinations yellow/grey, yellow/white, blue/ green, red/green, black/violet, or red/black, since these combinations are

unreadable for people with various visual conditions (i.e. colour blindness). Refer to Appendix C for more information.

*Colour contrast* shall be used as a safety measure to define edges or boundaries of objects (e.g., stair nosings, doors, *handrails*, etc.). Colour or tone shall be used to visually define the boundaries of a room (i.e., where the wall meets the floor). Baseboards in monochromatic environments shall be highly *contrasting* with the floor colours, to provide boundary definition.

Colour shall be used consistently to visually identify distinctive objects (e.g., exit doors).

Bright colours and/or a highly *contrasting* tone shall be used to assist with wayfinding (e.g. If used as part of a *signage* band located on walls at eye level, this band is easier to follow than monolithic wall colouring, and can be the visual cue for other essential signs.) (refer to Appendix B)

End walls or return walls in long corridors shall be visually defined using highly *contrasting* colours or tone, to enhance a change of direction or the end of the *space*.

*Detectable warning surfaces* shall be used to define potential hazards. (Refer to 4.4.8.). All textured surfaces used as *detectable warning surfaces* shall be clearly detectable by walking upon as being different from the surrounding surface. Suitable textures include raised domes or dots.

Supplementary textural cues shall also be provided (e.g., by using different floor textures or materials, in major and minor routes).

Clearly defined boundaries of materials like carpeting or floor tiles shall enhance wayfinding by defining such as the junction between walls and floors, doorway recesses and corridor intersections.

The same texture shall be used consistently throughout any one *site* to identify the same type of hazard.

## **RELATED SECTIONS**

4.1.2 Ground and Floor Surfaces

4.1.4 Accessible Routes, Paths and Corridors

4.1.6 Doors

4.1.7 Gates, Turnstiles and Openings

4.1.8 Windows, Glazed Screens and Sidelights

4.1.9 Ramps

4.1.10 Curb Ramps

4.1.11 Stairs

4.1.12 Handrails

4.1.13 Escalators

4.1.14 Elevators

4.1.15 Platform Lifts

4.2.2 Toilet Stalls

4.2.3 Toilets

4.2.4 Lavatories

4.2.5 Urinals

4.2.6 Washroom Accessories

4.2.7 Universal Washrooms

4.2.8 Bathtubs

4.2.9 Shower Stalls

4.2.10 Grab Bars

4.3.1 Drinking Fountains

4.3.3 Elevated Platforms

4.3.4 Dressing Rooms

4.3.5 Offices, Work Areas and Meeting Rooms

4.3.6 Waiting and Queuing Areas

4.3.8 Information, Reception and Service Counters

4.3.9 Storage, Shelving and Display Units

4.3.10 Lockers and Baggage Storage

4.3.11 Balconies, Porches, Terraces and Patios

4.3.14 Landscaping Materials and Plantings

4.3.15 Benches

4.3.16 Public Use Eating Areas

4.3.17 Streetscapes



4.4.1 Emergency Exits, Fire Evacuation and Areas of Rescue Assistance

4.4.2 Controls and Operating Mechanisms

4.4.5 Public Telephones

4.4.7 Signage

4.4.8 Detectable Warning Surfaces

4.4.11 Card Access, Safety and Security Systems

## **4.4.16 ACOUSTICS**

### **RATIONALE**

The acoustic environment of public buildings and *spaces* should accommodate the unique needs of persons who are hard of hearing and who need to differentiate essential sounds from general background noise. The sound transmissions of different areas can be used as an orientation cue and help to navigate a *space*. A well designed acoustical environment is to everyone's advantage.

### **APPLICATION**

The acoustical environment of *facilities* used by the general public, clients, customers and employees shall comply with this section.

### **DESIGN REQUIREMENTS**

Floor finishes, wall surfaces and ceilings shall be selected so that occasional noise is not unduly amplified. (e.g., Hard surfaces such as marble or terrazzo will allow each foot step to be heard by persons who are visually impaired, but add another level of confusion for persons who are hearing impaired.)

At *accessible routes* in large *facilities* where wayfinding is problematic, the sound transmission/reflection characteristics of finish materials shall aurally differentiate major and secondary paths of travel.

Ceiling shapes shall be designed so that echoes do not occur, unless an alternate acoustical treatment is incorporated. (Note: Domed shapes tend to distort sound.)

Public address and call systems shall be capable of being zoned to key areas, rather than blanketing all areas of a *facility* at all times. (Refer to 4.4.9.)

In *meeting rooms* and *assembly areas* where the spoken word is key to comprehending the proceedings, all unnecessary background noise (e.g., from fans or other mechanical equipment, air diffusers, etc.) shall be dampened and/or the room shall include adequate sound insulation.

### **RELATED SECTIONS**

4.3.5 Office, Work Areas and Meeting Rooms

4.3.8 Information, Reception and Service Counters

4.4.5 Public Telephones

4.4.6 Assistive Listening Systems

4.4.9 Public Address System

## **4.4.17 PEDESTRIAN SIGNALS**

### **RATIONALE**

Traffic signals should be designed to accommodate all users equally. The physical location of the controls can help identify specific directional paths, and auditory signals will enable user with low vision to locate the controls quickly.

### **APPLICATION**

Where new pedestrian signals are being installed or existing pedestrian signals are being replaced, they must be accessible.

### **DESIGN REQUIREMENTS**

Accessible pedestrian signals must

- have a locator tone that is distinct from a walk indicator tone;
- be installed within 1500 mm (59 in.) of the edge of the curb;
- be mounted at a maximum of 1100 mm (43-1/4 in.) above ground level;
- have tactile arrows that align with the direction of crossing;
- include both manual and automatic activation features;
- include both audible and *vibro-tactile walk indicators*.

Where two accessible pedestrian signal assemblies are installed on the same corner, they must be a minimum of 3000 mm (118 in.) apart.

Where the accessible pedestrian signal cannot meet the 3000 mm (118 in.) minimum requirement due to site constraints or existing infrastructure, two accessible pedestrian signal assemblies can be installed on a single post, and when this occurs, a verbal announcement must clearly state which crossing is active.

### **RELATED SECTIONS**

4.1.4 Accessible Routes, Paths, And Corridors

4.4.2 Controls and Operating Mechanisms

## 4.5 FACILITY-SPECIFIC REQUIREMENTS

### 4.5.1 ARENAS, HALLS AND OTHER INDOOR RECREATIONAL FACILITIES

#### RATIONALE

Opportunities for recreation, leisure and active sport participation should be available to all members of the community. Access should be provided to halls, arenas, and other sports *facilities*, including access to the *site*, all activity *spaces*, gymnasias, fitness *facilities*, lockers, change rooms and showers. Persons with a *disability* may be active participants, as well as spectators, volunteers and members of staff.

For waiting areas in these facilities, the provision of benches is important for individuals who may have difficulty with standing for extended periods.

#### APPLICATION

In addition to the design requirements specified in 4.1 to 4.4, arenas, halls and other indoor recreation *facilities* shall comply with this section.

Where dressing *facilities* are provided for use by the general public, clients, customers, performers or staff, at least 50%, but never less than one, for each type of use in each cluster of dressing *facilities* shall be *accessible* and in compliance with 4.3.4. It is preferable to have all dressing *facilities accessible*.

#### DESIGN REQUIREMENTS

Arenas, halls and other indoor recreation *facilities* shall

- where visitor, spectator and/or participant seating is provided,
  - have *accessible* seating options in compliance with 4.3.2; and
  - incorporate *detectable warning surfaces* in compliance with 4.4.8. where seating is accessed by stairs;
- provide an *accessible route* in compliance with 4.1.4 to the arena/*facility* floor and/or ice surface, including access panels or gates providing at least 950 mm (37-1/2 in.) *clear* width;
- where *facilities* are provided for performances and other events, have a direct *accessible route* in compliance with 4.1.4 from the lobby/*entrances* and viewing locations to all performing areas, including stages, dressing rooms, washrooms and all other *spaces* used by performers;
- where stairs are provided, have stairs that comply with 4.1.11, including appropriate tactile and *colour contrasting* features;
- where dressing *facilities* are provided, have dressing *facilities* that comply with 4.3.4;
- where lockers or shelving is provided, have lockers and shelving that comply with 4.3.9 and 4.3.10;
- where coat hooks are provided, have at least 10%, but never less than one, within the reach ranges specified in 4.1.1;
- where toilets and bathing *facilities* are provided, have toilets and bathing *facilities* that comply with 4.2.1;
- where concessions or other service counters are provided, comply with 4.1.3 and 4.3.8;

## **Exhibit A**

- where swimming pool, hot pools or therapy pools are provided, comply with 4.5.3; and
- where staff accommodation and related support areas, offices or *meeting rooms* are provided, comply with all relevant sections of 4.1 to 4.4.

To allow for Sledge Hockey in arenas, construct accessible player's boxes where the boards can be removed and clear Plexiglas is used with low thresholds. Refer to the CRFC (Canadian Recreation Facilities Council) Sledge Hockey Accessibility Design Guidelines for Arenas.

### **RELATED SECTIONS**

All relevant parts of Sections 4.1, 4.2, 4.3 and 4.4.

## 4.5.2 OUTDOOR RECREATIONAL FACILITIES

### RATIONALE

Opportunities for recreation, leisure and active sport participation should be available to all members of the community. Access should be provided to playing fields and other sports *facilities*, including access to the *site*, all activity areas, outdoor *recreational trails*, docks, swimming areas, play *spaces*, lockers, change rooms and showers. Persons with a *disability* may be active participants, as well as spectators, volunteers and members of staff.

### APPLICATION

In addition to the design requirements specified in 4.1 to 4.4, the outdoor recreation *facilities* listed below shall comply with this section.

Where dressing *facilities* are provided to support the use of outdoor recreational *facilities* by the general public, clients, customers, performers or staff, at least 50%, but never less than one, for each type of use in each cluster of dressing *facilities* shall be *accessible* and in compliance with 4.3.4. It is preferable to have all dressing *facilities accessible*.

### DESIGN REQUIREMENTS

#### GENERAL

*Parks* accessibility shall encompass the development of routes, auxiliary services, planting and an overall environment which is *accessible* and provides a fulfilling recreational experience for all persons with a varying level of ability.

#### BOARDWALKS

Where boardwalks are provided, they shall:

- have a minimum width of 2100 mm (78-3/4 in.);
- incorporate surfaces constructed of firm, stable, non-slip materials. (Where wooden planks are used, they shall be laid perpendicular to the *path of travel* and have joints no greater than 6 mm (1/4 in.) wide) and must comply with 4.4.14;
- incorporate a continuous curbed edge where the grade drop-off on any side of the boardwalk is greater than 200 mm (7-7/8 in.). The curbed edge shall be at least 75 mm (3 in.) high and of a *contrasting* colour to the surrounding terrain;
- have *handrails*, guards or other suitable barriers on both sides where the grade drop-off is greater than 450 mm (17-3/4 in.);
- comply with the requirements for ramps set out in 4.1.9 should the boardwalk have a running slope steeper than 1:20 (5%);
- have access points to boardwalks that allow easy wheelchair access; and
- have benches, garbage cans, drinking fountains, etc., where provided, located adjacent to the boardwalk on firm, level surfaces at the same elevation as the boardwalk. (Refer also to 4.3.17.).

DOCKS/PIERS

Where docks for fishing, boating or swimming are provided they shall

- be located on an *accessible route* in compliance with 4.1.4;
- incorporate firm and stable surfaces at transition points (such as from a *walkway* to a dock, or between adjacent dock units);
- incorporate clearly painted markings at transition points;
- where changes in elevation are necessary, incorporate *ramps* or *curb ramps* in compliance with 4.1.9 and 4.1.19 (ramps with a slope no greater than 1:20 (5%) at low water are acceptable);
- be no higher than 600 mm (23-3/4 in.) above the water, at average high water levels;
- incorporate a continuous curbed edge, at least 75 mm (3 in.) high and of a *contrasting* colour where dock surfaces are greater than 200 mm (7-7/8 in.) above the surface of the water;
- incorporate a *guard* where dock surfaces are greater than 450 mm (17-3/4 in.) above the surface of the water; and
- where steps are provided to access the water for swimming, incorporate *colour contrasting handrails* at the steps. Such *handrails* shall extend to a minimum of 600 mm (23-5/8 in.) above the dock surface and return down to the dock.

OUTDOOR POOLS

Outdoor swimming pools shall comply with 4.5.3.

RECREATIONAL TRAILS AND FOOTBRIDGES

Entrances to *recreational trails* shall have a clear opening between 950 - 1000 mm (37-1/2 - 39-3/8 in.).

*Recreational trails* shall have a width at least 1000 mm (39-3/8 in.).

*Recreational trails* shall have a clear height that provides a minimum head room clearance of 2,100 mm above the trail.

Where significant changes in grade occur, trail routes shall ideally be sloped at no greater than 1:20 (5%), or have adjacent steps and/or *ramps*.

Where steps, footbridges or *ramps* are used, the surfacing shall be of non-slip materials and include suitable *colour contrasting handrails* and/or *guards*.

The slope on bridges shall not exceed 1:20 (5%).

Ramps shall conform with 4.1.9.

Signage shall

- be provided at recreational trail head;
- comply with 4.4.7 Signage; and

- identify
  - length of recreational trail;
  - type of surface;
  - average and minimum width;
  - average and maximum running slope and cross slope; and
  - location of *amenities* where provided.

Where special lookout locations or viewing areas are provided, they shall be identified with clear signage.

Tactile maps should be considered at the start of the recreational trail and periodically along its length.

Braille should be considered for information and interpretive signage.

Alternative messaging systems can be incorporated i.e. audio or digital applications. For best practices refer to CNIB: Clearing our Path, Universal design recommendations for people with vision loss.

Where other media is used (website, brochure, etc.) to provide information about the recreational trail, beyond advertising, notice or promotion, the media must provide the same information as listed on required trail head signage.

Where adjacent to water or a drop off in grade that is greater than 200 mm (7-7/8 in.), and where a protective barrier is not provided, *recreational trails* shall incorporate edge protection such that

- it constitutes an elevated barrier that runs along the edge of the recreational trail in order to prevent users of the trail from slipping over the edge;
- the top edge of protection shall be at least 50 mm (2 in.) high; and
- the edge protection does not impede the drainage of the trail surface.

Exceptions to the requirements that apply to *recreational trails* are permitted where the requirements, or some of them, would likely affect the heritage, historic, cultural or natural heritage value of an area. Refer to Part IV.1 of Ontario Regulation 191/11 (Integrated Accessibility Standards).

Organizations shall consult with the public, including people with disabilities, about the design of *recreational trails*. Municipalities must also consult with their accessibility advisory committee, if they have one. The consultation process must address:

- Trail Slope
- Need for and location of ramps
- Need for, location, and design of rest areas, passing areas, viewing areas and *amenities* along the recreational trail.

PATHWAYS

*Accessible routes* and *walkways* shall conform with 4.1.4.

Garbage cans, light standards, benches and other potential obstructions shall be located adjacent to pathways. (Refer also to 4.3.17.)

A different ground colour, texture and/or landscape configuration such as separation, layout, offset gates, bollards, berms, planting, furniture, etc. should be considered to indicate the following (Refer also to 4.4.15.):

- risk areas, such as intersections, *ramps* or steps; and
- functional changes, such as seating areas, viewpoints or outlooks.

PLANTING AND TREES

Planting and trees along *accessible* pathways shall comply with 4.3.14.

GARDEN BEDS

Where new plant beds are provided for gardening use of the general public, clients, customers or employees, at least 10% of the area of the plant beds, but not less than one, shall comply with this section. It is preferable to have most plant beds comply with this section.

*Accessible* gardening beds shall be

- raised 460 mm (18 inches) above the adjacent floor or ground surface; and
- located on an *accessible route* complying with 4.1.4.

REST AREAS

Rest areas shall

- be provided on *recreational trails*, pathways and walkways every 30 to 90 m (98 ft. - 5 in. to 295 ft. - 3 in.); and
- have *accessible* ground surfaces in compliance with 4.1.2.

Organizations shall consult with the public including people with disabilities about the need for, location, and design of rest areas, passing areas, viewing areas, and *amenities* (accessible seating) along trails. Municipalities must also consult with their Accessibility Advisory Committee.

PARKS, PARKETTES AND PLAYGROUNDS – GENERAL

*Entrance* gates, paths and walkways throughout the park shall be *accessible* to a person using a wheelchair or scooter.

Picnic and *play areas* shall be provided in both sunny and shaded areas.



PLAYGROUNDS

Organizations shall consult on the needs of children and caregivers with various disabilities and shall do so in the following manner:

- Public sector organizations and large organizations shall consult with the public and persons with disabilities;
- Municipalities shall also consult with their municipal accessibility advisory committees, where one has been established.

The consultation process must address requirements for accessible play elements for children and caregivers with various disabilities including, but not limited to sensory and active play components.

Children's *play areas* and playground equipment, sandboxes or other *amenities* shall generally be designed to be *accessible* to and useable by children with varying levels of ability. Provide sufficient clearance to provide children and caregivers with various disabilities the ability to move through, in and around the outdoor play space. *Colour contrast* is important.

Playground surfaces shall be firm, level, non-abrasive and drain rapidly. Surfaces below playground equipment, including swings, slides and climbing structures, shall be level, free-draining and provide a safe, resilient landing surface.

Playgrounds should be designed with reference to the National Standard CAN/CSA-Z614 for "Children's Playspaces and Equipment (current version).

PICNIC TABLES

*Accessible* picnic tables shall comply with 4.3.16.

Where public parking is provided to serve picnic *facilities*, *accessible* picnic area(s) shall be provided within 30 m (100 ft.) of the *accessible* parking spaces.

BARBEQUES

Where barbecues are provided in outdoor public use eating areas, some shall

- be installed on a firm and flat surface with high tonal and textural contrast with the adjacent surfaces;
- have a surrounding clear space of 1500 mm (59 in.); and
- have a grill located between 800 mm (31-1/2 in.) and 920 mm (36-1/4 in.) from the ground.

DRINKING FOUNTAINS

*Accessible* drinking fountains shall comply with 4.3.1.

PUBLIC TELEPHONES

*Accessible* public telephones shall comply with 4.4.5.

## ILLUMINATION (WHERE PROVIDED)

Illumination levels shall

- shall comply with 4.4.13;
- be a minimum Average Maintained level of 5 lux (0.5 ft-candles);

Light sources used shall be indirect, non-glare, non-flickering type and provide even levels of light distribution. (Refer also to 4.4.13.)

## WASHROOMS

Where washrooms are provided to support the use of outdoor recreation *facilities* by the general public, clients, customers, performers or staff, they shall comply with all applicable sections of 4.2.

## WATERFRONT AREAS

Where paths and/or lookout points are provided, they shall be *accessible* to all individuals.

Seating shall be provided along paths and at lookout points, in compliance with 4.3.15.

Where parking is provided, it shall be located as close as possible to waterfront area. An *accessible route* shall be provided from the parking area to paths and/or lookout points (where provided).

## NATURAL AREAS

*Accessible* pathways, trails and footbridges shall be provided where environmental considerations will permit.

*Paths* and trails shall incorporate rest areas with appropriate seating.

Where special lookout locations or wildlife viewing areas are provided, they shall be identified with *clear signage*.

Trails should consider featuring a map and/or *tactile* map at the start of the trail and periodically along its length.

Information and interpretive *signage* may incorporate Braille.

## GRANDSTAND AND OTHER VIEWING AREAS

Where visitor, spectator and/or participant seating is provided, *accessible* seating options in compliance with 4.3.2 shall be provided.

## PLAYING FIELDS

Controlled access points shall be designed to accommodate a person using a wheelchair or scooter. (e.g., Where turnstiles are used, an adjacent *accessible* gate shall be provided in compliance with 4.1.7.)

Level seating areas shall be provided beside sports fields for spectators or participants with *disabilities*.

Where provided, public viewing areas shall comply with 4.3.2.

Where provided, public washrooms shall comply with 4.2.1.

Where provided, public showers and change rooms shall comply with 4.2.1, 4.2.9 and 4.3.4.

### ACCESS TO SPECTATOR AREAS OF SPORTS FIELDS

- Where designated spectator areas are provided at sports fields, they shall be accessible; and
- Pedestrian *pathways* to spectator areas of sports fields shall be designed to comply with RECREATIONAL TRAILS AND FOOTBRIDGES requirement of this section.

### LEASH FREE DOG PARKS

- *Entrance* gates into dog parks shall be a minimum of 950 mm (37-1/2 in.) wide; and
- Pedestrian *pathways* within leash free dog parks shall be designed to comply with the RECREATIONAL TRAILS AND FOOTBRIDGES requirement of this section.

### OUTLOOKS

Where scenic outlooks have been provided they shall:

- be located on an accessible route in compliance with 4.1.4;
- incorporate smooth and stable surfaces at transition points;
- incorporate continuous edge protection, at least 460 mm (18in.) high and of a *contrasting* colour around the edge of the outlook area where the grade drop-off is greater than 450 mm (17-3/4 in.); and
- if benches are provided, comply with 4.3.15.

### BEACH ACCESS ROUTES

Applicable to newly constructed and redeveloped *beach access routes* that an *obligated organization* intends to maintain, including permanent and temporary routes and temporary routes that are established through the use of manufactured goods, which can be removed for the winter months.

Where beach access is constructed (not natural):

- MAX cross slope no more than 1:50 (2%);
- 1:2 *bevel* at height change between 6-13 mm (1/4 - 1/2 in.);
- MAX running slope 1:10 (10%) at changes in level of 14 – 200 mm (1/2 - 7-7/8 in.); and
- Must have a ramp that meets requirements of 4.1.9 Ramps, where change of level is greater than 200 mm (7-7/8 in.).

Where surface is not constructed, the maximum cross slope must be the minimum slope required for drainage (i.e. 2%).

The maximum running slope of a beach access route is 1:10 (10%).

Entrance must have a clear opening of 1000 mm (39-3/8 in.) (whether the entrance includes gate, bollard, or other entrance design).

A *beach access route* must have a minimum clear width of 1000 mm (39-3/8 in.).

*Beach access routes* must be firm and stable with openings no greater than 20 mm (3/4 in.) and oriented perpendicular to the direction of travel.

A *beach access route* must have a clear height that provides a minimum head room clearance of 2100 mm (82-11/16 in.) above the beach access route.

### EXCEPTIONS

Exemptions to the requirements that apply to *recreational trails* and *beach access routes* are permitted where the requirements, or some of them, would likely affect the heritage, historical, cultural or natural heritage value of an area. Refer to Part IV.1 of Ontario Regulation 191/11 (Integrated Accessibility Standards).

*Beach access routes* must be firm and stable with openings no greater than 13 mm (1/2 in.) and oriented perpendicular to the direction of travel.

### **RELATED SECTIONS**

All relevant parts of Sections 4.1, 4.2, 4.3 and 4.4.

## **4.5.3 SWIMMING POOLS**

### **RATIONALE**

Swimming is an important recreational and therapeutic activity for many persons with *disabilities*.

The buoyancy and freedom offered by an immersive water environment can be enabling in themselves. Primary considerations for accommodating persons who have mobility *impairments* include *accessible* change facilities and a means of access into the water. Ramped access into the water is preferred over lift access, as it promotes integration (everyone will use the ramp) and independence. Many persons who are visually *impaired* will benefit from colour and textural cues along primary paths of travel and at potentially dangerous locations, such as the edge of the pool, at steps into the pool and at railings.

Therapeutic pools are generally smaller, shallower pools that include a ramp access and provide submerged bench seating in addition to open exercise space. The warm water in therapeutic pools is ideal for those recovering from an injury, living with chronic disease or who want to participate in a gentle but effective exercise program.

The benefits of Aquatic Therapeutic exercise are:

- Warm water promotes relaxation;
- Reduced pain;

- Decreased muscle tension;
- Improved circulation;
- Increased ability and length of time for exercise; and
- Helps to maintain an independent lifestyle.

**APPLICATION**

In addition to the design requirements specified in 4.1 to 4.4, swimming pools, wading pools, hot pools, splash pads, spray pads and therapy pools, and spas shall comply with this section.

**DESIGN REQUIREMENTS**

Swimming pools, wading pools, hot pools, public spas and therapy pools shall have

- where the pool is indoors,
  - a direct *accessible route* in compliance with 4.1.4 from the lobby/*entrance* to the change rooms; and
  - a direct *accessible route* in compliance with 4.1.4 from the change rooms to the pool deck;
- where the pool is outdoors,
  - an accessible route in compliance with 4.1.4 throughout the normally occupied portions of the pool; and
  - a pool deck that is minimum 1800 mm (70-7/8 in.) wide with a clear accessible route in compliance with 4.1.4 around the entire perimeter;

Access from the pool deck into the water, provided by a *ramp* that shall have

- a handrail on either side at 865 - 965 mm (34 - 38 in.);
- a clear width of at least 1100 mm (43-1/4 in.);
- a curb or other means to prevent a wheelchair from falling off the side;
- surface finishes capable of being kept clean, sanitary and free from slipperiness;
- where the ramp is not submerged it shall
  - have a landing at the bottom of the ramp that is at least 450 - 550 mm (18 - 21-3/4 in.) below the top of the wall;
  - be equipped with a floor drain at the lowest point;
  - have a width at the top of the wall between the pool and ramp of 250 - 300 mm (10 - 11-3/4 in.);
  - have water depth at the landing clearly marked in figures at least 100 mm (3-15/16 in.) high on the top of the wall; and
  - have a maximum slope of 1:12 (8.3%);
- where the ramp is submerged it shall
  - have water depth at the bottom of the ramp of 600 - 900 mm (23-5/8 - 35-1/2 in.);
  - have a hard-surfaced area that is at least 750 mm (29-1/2 in.) wide contiguous to the entire length of the submerged ramp;
  - have finishes that are different in colour or shade from each other and from that of the pool walls and bottom; and
  - have a maximum slope of 1:9 (11.1%);

## Exhibit A

- a shower chair available at each *facility* for use in transferring into the water and/or shower;
- where steps are provided into the pool, steps shall be marked with a *colour contrasting* strip of at least 50 mm (2 in.) wide, at both the riser and the tread; and *colour contrasting handrails* on both sides of the steps. Such *handrails* shall extend at least 300 mm (11-3/4 in.) beyond the pool edge;
- where a curbed edge is provided, it shall be a minimum of 200 mm (7-7/8 in.) and a maximum of 400 mm (15-3/4 in.) in height;
- pool boundaries clearly defined by both a textural change and a *colour contrast* to both the water surface and surrounding pavement;
- perimeter of pool deck clearly delineated by a tactile surface indicator around the pool;
- firm, slip-resistant materials and finishes used on the pool perimeter, deck or paved areas surrounding the pool;
- non-abrasive and easy-to-clean pool perimeter finishes;
- adequate drainage on the pool deck to drain water quickly;
- where pool-depth indicator marking is provided, depth-indicator markings, as well as 'SHALLOW END' and 'DEEP END' markings, of a highly *contrasting* colour and sufficient size to be easily visible;
- where diving boards or platforms are provided, they shall be clearly marked and protected. Overhead clearances should be a minimum of 2100 mm (82-3/4 in.) or shall be protected by suitable *guards*;
- where lanes, and/or lane markers are provided, they shall be of a highly *contrasting* colour. Tie-off devices for lane markers shall be positioned such that they do not create a tripping hazard;
- where starting blocks are provided, they shall be of a highly *contrasting* colour and capable of being securely fixed in place;
- safety equipment and other accessories shall be stored such that they do not present a tripping hazard; and
- lifeguard chairs, slides and other pool related structures shall be in highly *contrasting* colours.

In retrofit situations where it is technically infeasible to provide a ramp, a mechanical pool lift may be used. Some pools may have both a ramp and pool lift. The pool lift has a sling lift that provides a higher level of assistance for those who may require this level of support.

Where a mechanical pool lift is provided,

- it should not be installed where water level exceeds 1220 mm (48 in.) unless entire pool depth is more than 1220 mm (48 in.);
- the centerline of the seat should be located over the deck and a minimum 400 mm (15-3/4 in.) from the edge of the pool when in raised position;
- a clear space beside the seat opposite the water at least 915 mm (36 in.) wide and extended forward not less than 1220 mm (48 in.) from a line located 305 mm (12 in.) behind the rear edge of the seat shall be provided;

## Exhibit A

- it shall be capable of unassisted operation from both deck and water levels and be unobstructed when the lift is in use; and
- it shall have a weight capacity of at least 135 kg (300 lbs.) and capable of static load at least 1.5 times the rated load.

Wading pool access shall be safe and gradual so that a child with a *disability* can be assisted into the water easily and/or use a wheelchair to enter.

Swimming pools shall be of 'level-deck' design.

Where saunas and steam rooms are clustered, at least 5%, but no less than one of each type, shall be accessible and shall provide a clear floor space allowing a person using a wheelchair to make a 180-degree turn.

All doors to accessible saunas and steam rooms shall comply with Section 4.1.6.

Where seating is provided in the sauna/steam room, at least one accessible bench should be provided to the following specifications:

- The bench should be mounted 430 mm (17 in.) to 485 (19-1/8 in.) mm above the finished floor;
- There should be clear floor space provided alongside the bench to allow a person using a wheelchair to make a parallel transfer onto the bench;
- The bench should be capable of supporting a minimum load of 1.33 kN (300 lbs); and,
- Where the bench is installed in conjunction with showers, swimming pools, or other wet locations, it should be designed so that water will not accumulate upon the surface of the bench, and the top surface should be constructed of a slip-resistant material.

### THERAPEUTIC POOLS/PUBLIC SPAS

Water temperature shall be heated to between 33-34°C (92 - 94°F).

Temperature or other controls associated with the therapy pool (such as submerged water jets) shall meet requirements in 4.4.2.

Depth for the exercise portion of a therapy pool shall be between 1050 - 1200 mm (41 - 47 in.).

Submerged benches shall comply with 4.3.15.

Exercise bars (below water level) shall be incorporated into the design of a therapy pool.

A public spa shall be surrounded by a hard-surfaced deck that

- shall have a minimum clear deck space of not less than 1800 mm (70-7/8 in.) at the main entrance point; and
- shall have a minimum clear deck space of 900 mm (35-1/2 in.) on all sides.

## Exhibit A

Exception: where the public spa has an area of less than 6 square metres, and has no interior dimension of more than 2500 mm (98-1/2 in.), one section of the pool deck that does not exceed 25% of the perimeter may have a minimum clear deck space of not more than 300 mm (11-5/8 in.).

Where a set of steps is provide for entry into and egress from the public spa, the steps shall

- be equipped with a handrail;
- have a non-slip surface; and
- have a band of *contrasting* colour along the entire juncture of the side and top of the edges.

The slope of the bottom of any portion of a public spa shall not exceed 1:12 (8%).

The maximum depth of water to a seat or bench in a public spa shall be 600 mm (23-5/8 in.).

At least one accessible access point shall be provided into a public spa. The access point shall be a ramp in compliance with this section or a transfer wall. A transfer wall shall:

- have a height of 405 - 485 mm (16 - 19 in.) above pool deck;
- have depth between 300 and 400 mm (11-3/4 - 15-3/4 in.);
- be slip-resistant and have edges rounded;
- have minimum one grab bar
  - perpendicular to pool and extending full depth of transfer wall;
  - located between 100 - 150 mm (4 - 5-7/8 in.) above transfer wall; and
  - with clearance of at least 610 mm (24 in.) on both sides;
- have adjacent clear deck area for lateral transfer to the transfer wall that
  - is outside of and adjacent to barrier free *path of travel*;
  - has no obstructions at side of transfer wall;
  - has clear space of 900 (35-1/2 in.) x 2200 mm (86-5/8 in.); and
  - has a slope less than 2% at base of transfer wall surface; and
- have adjacent clear deck area centred grab bar where one grab bar is provided, or centred on the clear space between grab bars where more than one is provided.

An emergency telephone with direct connection to emergency services shall be installed within 30 m (98 ft. 5 in.) of a public spa.

All pumps in a public spa shall be capable of being deactivated by an emergency stop button that is clearly labeled and located within sight and readily accessible within 15 m (49 ft. 2-1/2 in.) of persons using the public spa. The emergency stop control shall be separate from the timing device, activate an audible and visual signal when used, and be identified with emergency signage.

### SPRAY PADS

Spray pads shall be designed

- with an accessible route to the facility;



- without a curb wherever possible, except in instances of uneven surface located adjacent to the pad where the installation of a curb may be necessary;
- to have a non-slip surface; and
- with all vertical elements to have high *colour contrast* with the surrounding elements and environment.

**RELATED SECTIONS**

All relevant parts of Sections 4.1, 4.2, 4.3 and 4.4.

**4.5.4 CAFETERIAS****RATIONALE**

Cafeteria serving lines and seating area designs need to reflect the lower sight lines, reduced reach, knee-space and maneuvering requirements of a person using a wheelchair or scooter. Patrons using mobility devices may not be able to hold a tray or food items while supporting themselves on canes or while maneuvering a wheelchair. Tray slides should be designed to move trays with minimal effort.

Features such as *colour contrasts* and large print menus may assist persons with a visual *impairment*.

**APPLICATION**

In addition to the design requirements specified in 4.1 to 4.4, cafeterias shall comply with this section.

Where fixed tables or counters are provided, at least 10%, but not less than one, shall be *accessible* and shall comply with 4.3.7. It is preferable to have all fixed tables *accessible*.

In new construction, and where practicable in *alterations*, the fixed tables (or counters) shall be distributed throughout the *space*.

At least one lane at each cashier area shall be *accessible* and comply with this section. It is preferable to have all lanes at all cashier areas *accessible*.

**DESIGN REQUIREMENTS**

Where food or drink is served at counters exceeding 865 mm (34 in.) in height and counters are for use by customers seated on stools or standing at the counter, a minimum of 1525 mm (60 in.) length of the counter shall be constructed in compliance with 4.3.8. Service may also be made available at *accessible* tables within the same area.

Every area where food is intended to be processed, prepared or manufactured and where equipment or utensils are intended to be cleaned shall be equipped to provide illumination to a level of not less than 500 lux (5-ft candles) measured at the floor level.

If a microwave is provided for public use, it should comply with the requirements for microwaves under the Kitchen section.

## Exhibit A

Access *aisles* at least 1100 mm (43-1/4 in.) shall be provided up to and around all *accessible* fixed tables. The *access aisle* shall be measured between parallel edges of tables or between a wall and the table edges.

Dining areas, including raised or sunken dining areas, and outdoor seating areas shall be *accessible*. In a retrofit situation where it is *technically infeasible* to provide access to all levels within a dining area, or to all parts of outdoor seating areas, at least one dining area shall be *accessible*. The *accessible* area must feature the same level of service and *décor* as the rest of the dining area and it must not be restricted to use by persons with *disabilities*.

A minimum of 20% of the tables must be accessible to persons using mobility aids (AODA, IASR, Design of Public Spaces).

Access to outdoor eating areas shall comply with 4.3.11.

Food service lines shall have a minimum *clear* width of 1100 mm (43-1/4 in.).

Tray slides shall be mounted no higher than 865 mm (34 in.).

If self-service shelves are provided, at least 50% must be within the reach ranges specified in 4.1.1. It is preferable to have all self-service shelves *accessible*.

Self-service shelves and dispensing devices for tableware, dishware, condiments, food and beverages shall be installed to comply with 4.1.1.

Cashier locations should feature at least one *access aisle*, which is a minimum of 1100 mm (43-1/4 in.) wide. It is preferable to have all aisles *accessible*.

In banquet rooms or *spaces* where a head table or speaker's lectern is located on a raised platform, the platform shall be *accessible* in compliance with 4.1.9 or 4.1.15, as well as 4.3.3.

*Spaces* for vending machines, beverage dispensers and other equipment shall comply with 4.1.1 and shall be located on an *accessible route* in compliance with 4.1.4.

Barriers and/or turnstiles, where provided to control access, shall comply with 4.1.7.

Queuing areas shall comply with 4.3.6.

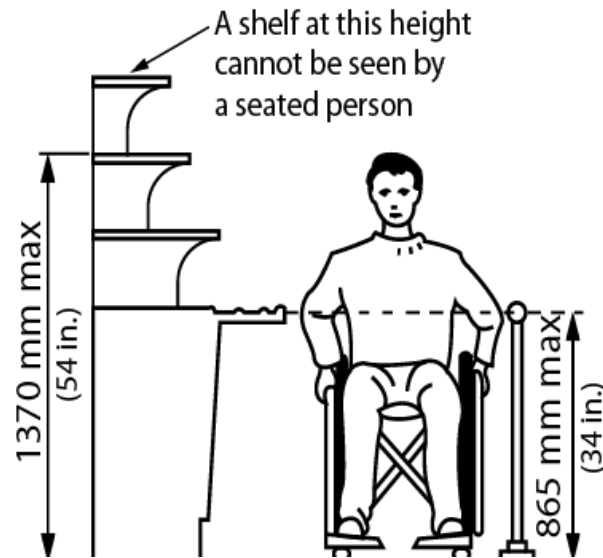


Figure 4.5.4.1 Self-Serve Counter

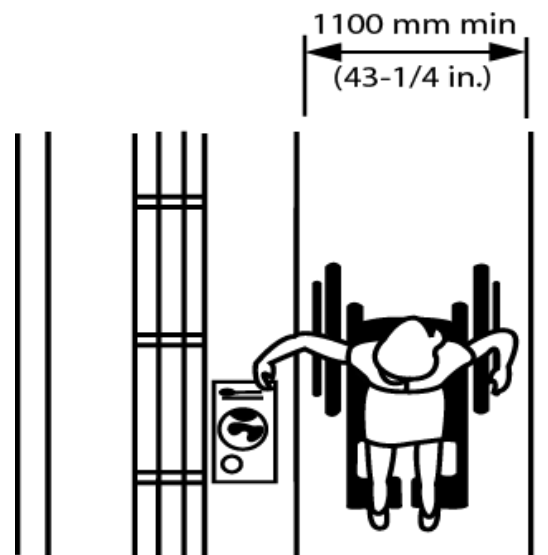


Figure 4.5.4.2 Aisle Width

#### RELATED SECTIONS

All relevant parts of Sections 4.1, 4.2, 4.3 and 4.4.

### 4.5.5 CHURCHES, CHAPELS AND OTHER PLACES OF WORSHIP

#### RATIONALE

Access to all areas of worship should be provided. Access assumes that persons with *disabilities* may be participants, leaders, staff or volunteers.

#### APPLICATION

In addition to the design requirements specified in 4.1 to 4.4, churches, chapels and other places of worship and/or reflection shall comply with this section.

## DESIGN REQUIREMENTS

All areas in churches, chapels and other places of worship and/or reflection shall be *accessible* to persons with *disabilities*, including main areas of worship, *meeting rooms*, washrooms, coatrooms and offices.

*Accessible* seating shall be provided in compliance with 4.3.2.

Pulpits, altars, daises and choir areas shall comply with 4.3.3.

Public address systems shall comply with 4.4.9.

Assistive listening systems shall comply with 4.4.6.

## RELATED SECTIONS

All relevant parts of Sections 4.1, 4.2, 4.3 and 4.4.

### 4.5.6 LIBRARIES

#### RATIONALE

Traditional and automated systems should be available to all patrons and staff. Both the design of the *facility* and the provision of services should be considered. Service counters and study carrels should accommodate the knee-space and armrest requirements of a person using a wheelchair. Computer catalogues, carrels and workstations should be provided at a range of heights, to accommodate persons who are standing or sitting, as well as children of many ages and sizes. It is preferred to provide height-adjustable furnishings.

The provision of workstations equipped with assistive technology such as large displays, screen readers, etc. will increase the accessibility of a library.

The provision of book drop-off slots at different heights for standing and seated use will enhance usability.

#### APPLICATION

In addition to the design requirements specified in 4.1 to 4.4, libraries shall comply with this section.

Where fixed seating, tables or study carrels are provided, at least 10% but no less than one shall be *accessible* and in compliance with this section. It is preferable to have all fixed seating, tables and study carrels *accessible*.

At least one lane at each checkout area shall be *accessible* and comply with this section. It is preferable to have all lanes at all checkout areas *accessible*.

Where computer catalogues or workstations are provided, at least 50% shall be *accessible* and shall comply with this section. It is preferable to have all computer catalogues and workstations *accessible*.

**DESIGN REQUIREMENTS**

*Accessible* fixed seating, tables and study carrels shall be located on an *accessible route* in compliance with 4.1.4.

Clearances between fixed seating, tables and study carrels shall comply with 4.1.4.

Where shelving is provided at fixed seating, tables or study carrels, the shelving shall be no higher than 1200 mm (47 in.).

*Accessible* fixed study carrels shall incorporate

- work surfaces and knee/toe clearance in compliance with 4.1.1;
- an electrical outlet; and
- lighting levels of at least 100 lux (9.3 ft-candles) at the work surface.

Where provided, traffic control or book security gates shall comply with 4.1.7.

Minimum *clear aisle space* at card catalogues and at stacks shall comply with 4.1.1

Aisle configurations shall incorporate a *clear floor space* allowing a person in a wheelchair to make a 180-degree turn in compliance with 4.1.1.

Maximum reach heights at card catalogues shall comply with 4.1.1.

Shelf height in stack areas is unrestricted.

Circulation service counters and information service counters shall comply with 4.3.8.

Where provided, computer catalogues and computer workstations shall incorporate

- knee and toe *space* below the work surface in compliance with 4.1.1 and 4.3.7;
- a maximum work surface height of 865 mm (34 in.); and
- a maximum table depth of 915 mm (36 in.).

A minimum of one movable chair shall be provided at every information service counter, computer catalogue or computer workstation.

Book drop slots shall

- be located on an *accessible route* complying with 4.1.4;
- be located adjacent to a 2440 by 2440 mm (96 by 96 in.) level *clear floor space*. In a retrofit situation where it is *technically infeasible* to create a 2440 x 2440 mm (96 by 96 in.) *clear floor space*, the *space* may be reduced to 1525 x 1525 mm (60 by 60 in.); and
- have a slot that is operable using one hand, located between 860 mm (34 in.) and 900 mm (35-1/2 in.) above the floor.

Lighting at book stacks shall be mounted directly over the aisle *space* and provide a minimum of 200 lux (20 ft-candles) at a nominal working height of 920 mm (36 in.).

## Exhibit A

The acoustic quality shall be free of unnecessary background noise and should permit comprehension by persons with limited hearing. (Refer also to 4.4.16.)

Where CDs, tapes, talking books, etc. are available as part of the library resource materials, or for loan purposes, a separate space shall be provided for auditing this material without disturbing other library users.

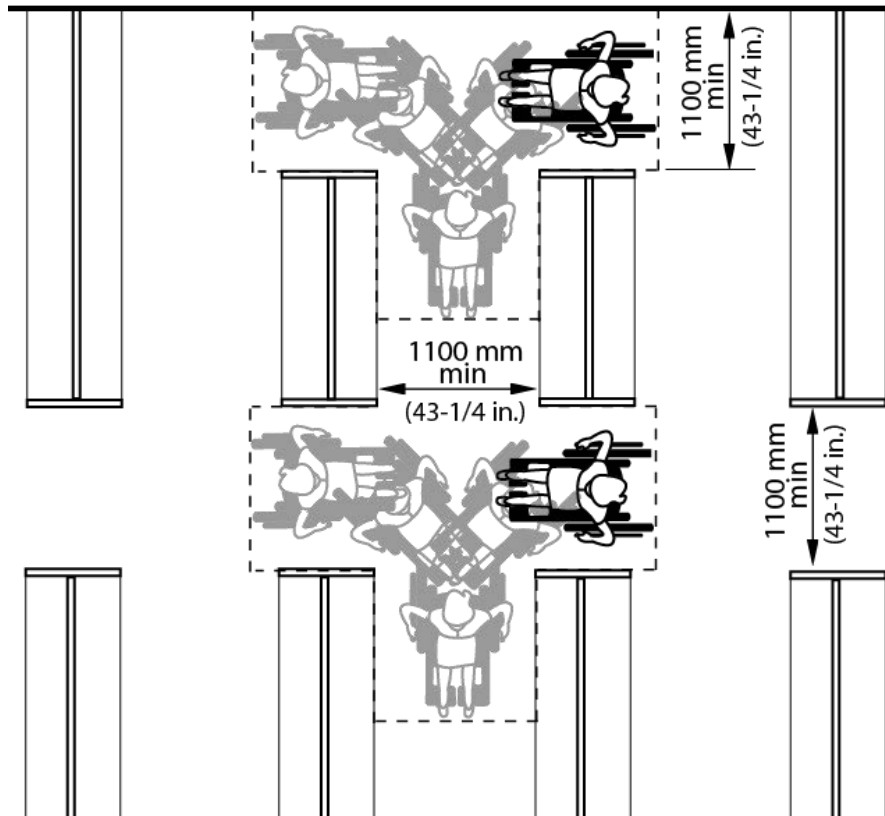


Figure 4.5.6.1 Aisle Width

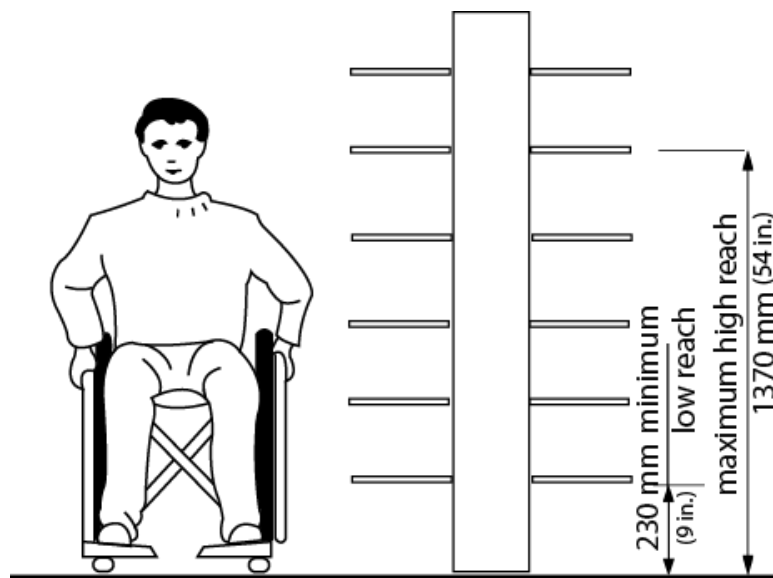
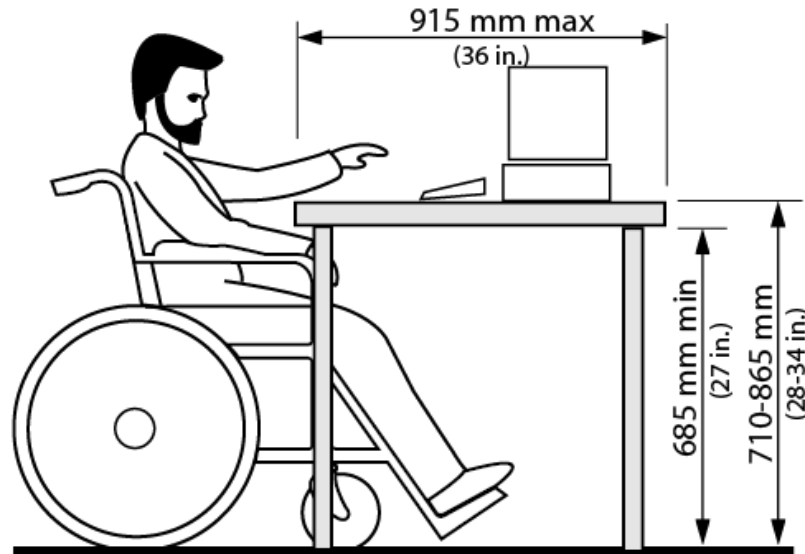


Figure 4.5.6.2 Reach Heights



**Figure 4.5.6.3 Work Surfaces**

## RELATED SECTIONS

All relevant parts of Sections 4.1, 4.2, 4.3 and 4.4.

## 4.5.7 BUSINESS, MERCANTILE AND CIVIC

### RATIONALE

The role of persons with *disabilities* should not be restricted or limited to that of the customer or consumer. Workspaces should be designed with a view to future adaptation or accommodation of individual equipment or *mobility assistive devices*.

### APPLICATION

In addition to the design requirements specified in 4.1 to 4.4, business, mercantile and civic *facilities* shall comply with this section.

In areas used for transactions where counters have cash registers and are provided for sales and distribution of goods or services to the public, at least one of each type shall have a portion of the counter *accessible* and in compliance with this section. Such counters shall include, but not be limited to, counters in retail stores and distribution centres.

Where counters are dispersed throughout the *facility*, the *accessible* counters must also be dispersed throughout the *facility*.

In public *facilities* where counters or teller windows have solid partitions or security glazing to separate personnel from the public, at least one of each type shall provide a method to facilitate voice communication. Such methods may include, but are not limited to, grills, slats, talk-through baffles, intercoms or telephone handset devices.

The number of *accessible* checkout aisles provided shall be in conformance with Table 4.5.7

**DESIGN REQUIREMENTS**

All *accessible* sales and service counters shall be on an *accessible route* that complies with 4.1.4.

In areas used for transactions where counters have cash registers and are provided for sales and distribution of goods or services to the public, the counter shall have at least one portion that is at least 920 mm (36 in.) in length, with a maximum surface height of 865 mm (34 in.) above the finished floor and shall have adjacent *clear floor space* of at least 1370 mm x 810 mm (54 x 32 in.) to allow for parallel approach by a person using a wheelchair or scooter.

In areas used for transactions that may not have a cash register but at which goods and services are sold, including, but not limited to, ticketing counters, teller stations, registration counters, information counters, box office counters and library check-out areas either a portion of the main counter shall be a minimum of 865 mm (34 in.) in length, with a maximum height of 865 mm (34 in.) or an auxiliary counter with the required minimum dimensions shall be provided in close proximity to the main counter.

In public *facilities* where counters or teller windows have solid partitions or security glazing to separate personnel from the public, the method of communication provided shall be *accessible* to both individuals who use a wheelchair or scooter and individuals who have difficulty bending.

The *clear* width of *accessible* checkout lines shall comply with 4.1.4, and the maximum adjoining counter height shall not exceed 965 mm (38 in.) above the finished floor. The top of any counter edge protection shall be no more than 50 mm (2 in.) above the top of the counter surface on the aisle side of the check-out counter.

*Signage* identifying *accessible* checkout aisles shall incorporate the Dynamic Symbol of Access and shall be mounted above the checkout aisle in the same location where the checkout number or type of checkout is displayed.

Any devices used to prevent the removal of shopping carts from store premises shall not prevent access or *egress* to persons who use a wheelchair or scooter. An alternate *entrance* that is equally convenient to that provided for ambulatory persons is acceptable.

| <b>Table 4.5.7 Required Number of Accessible Checkout Aisles</b> |  |
|--|--|
| <b>Total checkout aisles of each design</b>                      | <b>Minimum number of accessible checkout aisles of each type</b> |
| 1-4  | 1  |
| 5-8  | 2  |
| 9-15   | 3  |
| Over 15  | 3 plus 20% of additional aisles                                  |

**RELATED SECTIONS**

All relevant parts of Sections 4.1, 4.2, 4.3 and 4.4.



## 4.5.8 POLICE STATIONS

### RATIONALE

Police stations should accommodate persons with *disabilities* who may be members of the public, detainees, members of counsel or police staff. All areas of the police station that are used by the public, members of staff and counsel should be fully *accessible* to persons with *disabilities*. Secure areas, such as cells and common areas used by detainees, should have provisions to *accommodate* persons with *disabilities*.

### APPLICATION

In addition to the design requirements specified in 4.1 to 4.4, holding cells in police stations shall comply with this section.

Except as specified in this section, all *common use areas* serving *accessible* cells or rooms and all *public use areas* shall be designed and constructed to comply with 4.1 to 4.4. Exceptions: Requirements for *areas of rescue assistance* in 4.4.1 do not apply. Compliance with requirements for elevators and stairs is not required in multi-storey housing *facilities* where *accessible* cells or rooms, all *common use areas* serving them and all *public use areas* are located on an *accessible* route .

Entrances used by the public, including those that are secured, shall be *accessible* and in compliance with 4.1.5. Exception: Secured entrances, doors and doorways operated only by security personnel shall not be required to have *accessible* door hardware.

Where security systems are provided at public or other *entrances* required to be *accessible* by this section, an *accessible* route complying with 4.1.4 shall be provided through fixed security barriers at required *accessible entrances*. Where security barriers incorporate equipment such as metal detectors, fluoroscopes, or other similar devices which cannot be made *accessible*, an *accessible* route shall be provided adjacent to such security screening devices, to facilitate an equivalent circulation path for persons using a wheelchair or scooter.

In non-contact visiting areas where detainees are separated from visitors, the following *elements*, where provided, shall be *accessible* and located on an *accessible* route complying with 4.1.4.

Cubicles and Counters: 5%, but not less than one, shall comply with 4.3.7 on both the visitor and detainee sides. Where counters are provided, they shall comply with 4.3.8 on both the visitor and detainee sides. Exception: Non-contact visiting areas not serving *accessible* cells or rooms.

Partitions: Solid partitions or security glazing separating visitors from detainees through which communication is necessary shall incorporate communication systems which are *accessible* to both individuals who use a wheelchair or scooter and individuals who have difficulty bending. If such communication systems incorporate a telephone handset, at least one telephone handset shall be equipped with a volume control.

At least 2%, but not less than one, of the total number of cells shall comply with this section. Where special cells are provided (e.g., orientation, protective custody, disciplinary, segregation, detoxification or medical isolation), at least one of each purpose shall comply with this section.

In addition to the aforementioned cell requirements, at least 2%, but not less than one, of general cells shall be equipped with audible emergency warning systems or permanently installed telephones within the cell, in compliance with this section.

Medical care *facilities* providing physical or medical treatment or care shall be *accessible* to persons with *disabilities*.

## **DESIGN REQUIREMENTS**

*Accessible* cells shall be located on an *accessible route* in compliance with 4.1.4.

Where provided to serve *accessible* cells, the following *elements* or *spaces* shall be *accessible* and connected by an *accessible route*.

All doors and doorways on an *accessible route* shall comply with 4.1.6. Exception: Secured entrances, doors and doorways operated only by security personnel shall not be required to have *accessible* door hardware.

At least one toilet and one bathing facility shall comply with 4.2.1.

*Accessible* beds shall have maneuvering space of at least 920 mm (36 in.) wide along one side.

At least one drinking fountain and/or water cooler shall comply with 4.3.1.

Fixed or built-in tables, counters or work surfaces shall comply with 4.3.7.

At least one fixed bench shall comply with 4.3.15.

Fixed or built-in storage shall comply with 4.3.9.

All controls intended for operation by detainees shall comply with 4.4.2.

Where audible emergency warning systems are provided to serve occupants of cells, visual alarms complying with 4.4.4 shall also be provided. Exception: Visual alarms are not required where detainees are not allowed independent means of *egress*.

Where permanently installed telephones are provided within cells, they shall have volume controls.

## **RELATED SECTIONS**

All relevant parts of Sections 4.1, 4.2, 4.3 and 4.4.

## **4.5.9 MUNICIPAL COURTS**

### **RATIONALE**

Municipal court *facilities* should accommodate persons with *disabilities* who may be members of the judiciary, court clerks or other officials, defendants, members of counsel and members of the public.

Court *facilities* usually incorporate changes in level at the judge's dais and court officials' areas. While it is not required to make all of these areas fully *accessible*, it is a requirement that they be easy to adapt, should the need arise in the future to accommodate a person with a mobility *impairment*. Other

areas of the court generally used by the public, defendants, witnesses and counsel should be *accessible* to all persons.

## **APPLICATION**

In addition to the design requirements specified in 4.1 to 4.4, municipal courts shall comply with this section.

In addition to the *accessible entrances* used by staff or the public as required in 4.1.5, where provided, at least one restricted *entrance* and one secured *entrance* to the *facility* shall be *accessible*. Restricted *entrances* are those *entrances* used only by judges, public officials, *facility* personnel or other authorized parties on a controlled basis. Secure *entrances* are those *entrances* to judicial facilities used only by detainees and detention officers. Exception: Secured *entrances*, doors and doorways operated only by security personnel shall not be required to have *accessible* door hardware.

An *accessible* route complying with 4.1.4 shall be provided through fixed security barriers at required *accessible entrances*.

Where security barriers incorporate equipment such as metal detectors, fluoroscopes, or other similar devices which cannot be made *accessible*, an *accessible* route shall be provided adjacent to such security screening devices, to facilitate an equivalent circulation path.

Where a two-way communication system is provided to gain admittance to a *facility*, or to restricted areas within a *facility*, the system shall provide both visual and audible signals and shall comply with 4.4.2.

Where provided, the following *elements* and *spaces* shall be on an *accessible* route complying with 4.1.4.

**Spectator, Press and other areas with Fixed Seats:** Each spectator, press and other *area* with fixed seats having a seating capacity of 25 or less, shall have within its defined area a *clear floor space* complying with 4.1.1. Where the seating capacity of a spectator, press and other *area* with fixed seats is greater than 25, seating provision shall be provided in compliance with 4.3.2.

**Jury Boxes and Witness Stands:** Each jury box and witness stand shall have within its defined area *clear floor space* complying with 4.1.1.

**Judges' Benches and Courtroom Stations:** Judges' benches, clerks' stations, bailiffs' stations, court reporters' stations, and litigants' and counsel stations shall comply with 4.3.7.

Exceptions:

- Vertical access to raised judges' benches or courtroom stations need not be installed, provided that the requisite areas and maneuvering *spaces* are installed at the time of initial construction, to allow future installation of a means of vertical access complying with 4.1.9, 4.1.14 or 4.1.15 without requiring substantial reconstruction of the *space*.

- In alterations, *accessible clear floor spaces* are not required to be located within the defined area of jury boxes or witness stands and may be located outside these *spaces* where a *ramp* or lift access poses a hazard by restricting or projecting into a required means of *egress*.

Permanently installed assistive listening systems in compliance with 4.4.6 shall be provided in each courtroom. The minimum number of receivers shall be 4% of the room occupant load, but not less than two receivers. An informational sign indicating the availability of an assistive listening system shall be posted in a prominent place.

Where provided in areas for jury assembly or deliberation, the following *elements* or *spaces* shall be on an *accessible route* complying with 4.1.4 and shall comply with the following provisions

- refreshment areas, kitchenettes and fixed or built-in refreshment dispensers shall be *accessible* to persons with *disabilities*; and
- where provided, drinking fountains shall comply with 4.3.1.

## **RELATED SECTIONS**

All relevant parts of Sections 4.1, 4.2, 4.3 and 4.4.

## **4.5.10 TRANSPORTATION FACILITIES**

### **RATIONALE**

Links to usable transportation should be *accessible* to all members of a community. Accessibility within terminals and use of systems should be addressed. This includes public and private bus, taxi, train, and airplane arrival and departure points. A variety of lift devices may need to be accommodated, and alternatives to audio and/or visual-only scheduling should be available.

It is important to provide appropriate wayfinding guidance in open areas, including *tactile direction indicators*.

### **APPLICATION**

In addition to the design requirements specified in 4.1 to 4.4, transportation *facilities* located within a *site* shall comply with this section.

### **DESIGN REQUIREMENTS**

#### **BUS SHELTERS**

Bus shelters shall

- be located on firm, level pads approximately at the same elevation as the sidewalk or walkway;
- have clearances around at least two sides of the shelter, including the landing pad side, of at least 1220 mm (48 in.);
- provide a *clear* view of oncoming traffic where possible;
- incorporate sufficient clear floor space to accommodate a person using a wheelchair or scooter; and

- feature at least one seat with armrests and a seat height between 400 mm and 450 mm (15-3/4 in. and 17-3/4 in.).

All glazed panels surrounding bus shelters shall incorporate decals, and other safety features as specified in 4.1.8.

## BUS STOPS

Bus stops shall

- incorporate a paved, firm, level surface, in compliance with local authority standards; and
- not be impeded by adjacent street furniture, such as dispensers, vending machines, waste boxes, planters, posts, signs and guide wires.

## TRANSIT TERMINALS

Where bus platforms or other boarding platforms are provided, they shall allow safe access for persons who use a wheelchair or scooter, and where possible, provide level access into buses.

The edges of platforms shall incorporate a continuous *detectable warning surface* of at least 600 mm (23-5/8 in.) wide and in compliance with 4.4.8.

Lighting levels at all boarding platforms shall be at least 100 lux (10 ft-candles) at the platform or boarding-surface edge.

Where special lifting devices are used, either on the vehicle or at the boarding point, appropriate maneuvering *space* shall be provided around the boarding point for waiting passengers using wheelchairs.

Seating shall be provided in compliance with 4.3.15, at or close to boarding points.

## **RELATED SECTIONS**

All relevant parts of Sections 4.1, 4.2, 4.3 and 4.4.

## **4.5.11 FIRE HALLS**

### **RATIONALE**

Municipal fire stations should accommodate the accessibility needs of potential facility users (while supervised), including but not limited to:

- Injured staff attending a Captain's office or other meeting space within the facility;
- Administration staff, Council Members, Consultants, etc. attending site visits;
- Tours of non-work staff (School groups, etc.);
- Occasional uses of the facility;
- Fire stations contain spaces that may be used by the public while supervised by staff; and
- Use by members of the general public in an emergency situation (pedestrian walk-up &/or vehicular drop-in requests for assistance/emergency services).

Areas of fire stations likely to be used by the public, including the apparatus bay, should be accessible for persons with disabilities.

**APPLICATION**

Areas of a fire station that are accessible to the public and/ or intended for access/viewing by visitors shall comply with this section.

Exception: Facilities for the exclusive use of firefighters such as hose towers, fitness rooms, 2nd floors, dormitories, and any basement level storage space.

At least one accessible public washroom shall be provided.

**DESIGN REQUIREMENTS**

Public entrances shall be accessible and in compliance with 4.1.5.

Firefighter entrances shall be accessible and in compliance with 4.1.5, except that a power door operator is not required, unless it is required by the Ontario Building Code.

An accessible *path of travel* in compliance with 4.1.4 shall be provided from accessible public entrances to all spaces that are accessible to the public or intended for access/viewing by visitors.

Where more than 3 entrances are provided, a minimum of 2 barrier-free entrances are required (per OBC).

Where public parking is provided, at least one accessible parking space shall be located close to the primary public entrance.

Spaces that may be used by community and public within fire stations shall comply with Section 4.3.5.

Common-use areas within a fire station, such as the kitchen, shall comply with all relevant sections of this Standard.

**RELATED SECTIONS**

All other relevant parts of Sections 4.1, 4.2, 4.3 and 4.4.

**4.5.12 AIRPORTS**

**RATIONALE**

Accessibility within the public areas of the Norman Rogers Airport must be addressed.

**APPLICATION**

In addition to the design requirements specified in Sections 4.1 to 4.4, the Norman Rogers Airport shall comply with this section.

## **DESIGN REQUIREMENTS**

The airport is required to comply with all accessibility requirements of Transport Canada. These standards are considered to be a minimum.

If municipal standards are greater than the federal standards, then the municipal standards will apply, if they are appropriate and do not interfere with matters under federal jurisdiction.

## **RELATED SECTIONS**

All other relevant parts of Sections 4.1, 4.2, 4.3 and 4.4.

## **4.5.13 RESIDENTIAL FACILITIES**

### **RATIONALE**

The municipality is responsible for a number of affordable housing units. Accessibility to and within these units must be addressed for all new housing units, and for any existing units under-going major *alterations*.

### **APPLICATION**

In addition to the design requirements specified in Sections 4.1 to 4.4, municipally-owned residential *facilities* shall comply with this section.

### **DESIGN REQUIREMENTS**

All residential *facilities* shall comply with the Residential Accommodation provisions in the Canadian Standards Association (CSA) document “Accessible design for the built environment”.

### **RELATED SECTIONS**

All other relevant parts of Sections 4.1, 4.2, 4.3 and 4.4.

## 4.6 MAINTENANCE AND OPERATIONS

### RATIONALE

Property *maintenance* is important to ensure an *accessible* environment that is safe and useable by everyone. Such *maintenance* involves the proper care, cleaning and repair of a *facility*, maintaining it in good order and safe condition. Snow and ice removal are particularly important components of property *maintenance*.

### APPLICATION

All *accessible facilities*, *accessible elements* and systems within those *facilities*, and contained within the *facility site*, shall be maintained on a regular basis to ensure their continued usability and safety.

### MAINTENANCE REQUIREMENTS

*Accessible routes* and emergency exits/*areas of rescue assistance* shall be maintained, and kept free of objects, debris, snow, ice and/or excessive water accumulation. *Maintenance* shall include, but not be limited to, the timely removal of snow, ice, winter sand/salt, wet leaves and other debris from *accessible routes*, *curb ramps*, stairs, and *entrances*.

Designated areas for snow piling shall be provided at pedestrian routes, *entrances*, stairs, *ramps* and public parking areas. Snow storage shall not reduce the minimum width required for an exterior *accessible route*, or affect the usability of *accessible facilities*, *elements* or systems.

Regular and systematic checks shall be undertaken to ensure that no obstacles have been located in pedestrian routes (e.g., newspaper vending machines and bicycle racks or garbage containers).

*Operable elements* installed on or adjacent to *accessible* interior and exterior routes shall be inspected, well maintained on a regular schedule, and kept in operable condition.

These *elements* can include but are not limited to:

- Elevating devices;
- Power door operators;
- Swipe card access systems;
- Signage;
- Lighting;
- Controls;
- Gates;
- Closers;
- Mechanical chair lifts;
- Automatic ticket machines; and
- Other essential equipment.

When a portion of an *accessible route* is temporarily closed to users, a continuous alternative *accessible route* that complies with 4.1.4 (Accessible Routes, Paths and Corridors) shall be provided. The alternative *accessible route* shall be separated from vehicular routes, and the location and direction of the alternative *accessible route* shall be *clear* and easy to detect for



individuals of all abilities. *Alternate Route* signage should be provided including end date of disruption to be installed in compliance with 4.4.7.

Where *maintenance* work is contemplated/underway clear notification must be posted to inform all users of alternate routes to *accessible* features such as washrooms, *ramps*, *TTY* services, escalators, elevators and other systems provided to accommodate the needs of people with disabilities. Notification signs should not only be located and maintained at the *maintenance* sites but also at all *facility entrances*, receptions, and service counters. It is also important to ensure that posted notification signs are well-maintained and provide advanced notice of disruption in service.

# APPENDIX A - UNIVERSAL DESIGN PRINCIPLES AND GUIDELINES

Version 2.0 - 4/1/97

Compiled by advocates of universal design, listed in alphabetical order: Bettye Rose Connell, Mike Jones, Ron Mace, Jim Mueller, Abir Mullick, Elaine Ostroff, Jon Sanford, Ed Steinfeld, Molly Story, and Gregg Vanderheiden

Major funding provided by: The National Institute on Disability and Rehabilitation Research, U.S. Department of Education

Copyright 1997 NC State University, The Center for Universal Design

## UNIVERSAL DESIGN:

The design of products and environments to be usable by all people, to the greatest extent possible, without the need for adaptation or specialized design.

The authors, a working group of architects, product designers, engineers and environmental design researchers collaborated to establish the following Principles of Universal Design to guide a wide range of design disciplines, including environments, products, and communications. These seven principles may be applied to evaluate existing designs, guide the design process and educate both designers and consumers about the characteristics of more usable products and environments.

The Principles of Universal Design are presented here, in the following format: name of the principle, intended to be a concise and easily remembered statement of the key concept embodied in the principle; definition of the principle, a brief description of the principle's primary directive for design; and guidelines, a list of the key elements that should be present in a design which adheres to the principle. (Note: all guidelines may not be relevant to all designs.)

### PRINCIPLE ONE: Equitable Use

The design is useful and marketable to people with diverse abilities.

#### Guidelines:

- 1a. Provide the same means of use for all users: identical whenever possible; equivalent when not.
- 1b. Avoid segregating or stigmatizing any users.
- 1c. Provisions for privacy, security, and safety should be equally available to all users.
- 1d. Make the design appealing to all users.

### PRINCIPLE TWO: Flexibility in Use

The design accommodates a wide range of individual preferences and abilities.

#### Guidelines:

- 2a. Provide choice in methods of use.

2b. Accommodate right- or left-handed access and use.

2c. Facilitate the user's accuracy and precision.

2d. Provide adaptability to the user's pace.

### **PRINCIPLE THREE: Simple and Intuitive Use**

Use of the design is easy to understand, regardless of the user's experience, knowledge, language skills, or current concentration level.

#### **Guidelines:**

3a. Eliminate unnecessary complexity.

3b. Be consistent with user expectations and intuition.

3c. Accommodate a wide range of literacy and language skills.

3d. Arrange information consistent with its importance.

3e. Provide effective prompting and feedback during and after task completion.

### **PRINCIPLE FOUR: Perceptible Information**

The design communicates necessary information effectively to the user, regardless of ambient conditions or the user's sensory abilities.

#### **Guidelines:**

4a. Use different modes (pictorial, verbal, tactile) for redundant presentation of essential information.

4b. Provide adequate contrast between essential information and its surroundings.

4c. Maximize "legibility" of essential information.

4d. Differentiate elements in ways that can be described (i.e., make it easy to give instructions or directions).

4e. Provide compatibility with a variety of techniques or devices used by people with sensory limitations.

### **PRINCIPLE FIVE: Tolerance for Error**

The design minimizes hazards and the adverse consequences of accidental or unintended actions.

#### **Guidelines:**

5a. Arrange elements to minimize hazards and errors: most used elements, most accessible; hazardous elements eliminated, isolated, or shielded.

5b. Provide warnings of hazards and errors.

5c. Provide fail-safe features.

5d. Discourage unconscious action in tasks that require vigilance.

### **PRINCIPLE SIX: Low Physical Effort**

The design can be used efficiently and comfortably and with a minimum of fatigue.

#### **Guidelines:**

6a. Allow user to maintain a neutral body position.

6b. Use reasonable operating forces.

6c. Minimize repetitive actions.

6d. Minimize sustained physical effort.

### **PRINCIPLE SEVEN: Size and Space for Approach and Use**

Appropriate size and space are provided for approach, reach, manipulation, and use, regardless of user's body size, posture, or mobility.

#### **Guidelines:**

7a. Provide a clear line of sight to important elements for any seated or standing user.

7b. Make reach to all components comfortable for any seated or standing user.

7c. Accommodate variations in hand and grip size.

7d. Provide adequate space for the use of *mobility assistive devices* or personal assistance.

Please note that the Principles of Universal Design address only universally usable design, while the practice of design involves more than consideration for usability.

Designers must also incorporate other considerations, such as economic, engineering, cultural, gender, and environmental concerns, in their design processes. These principles offer designers guidance to better integrate features that meet the needs of as many users as possible.

## APPENDIX B - WAYFINDING

### RATIONALE

“Wayfinding” is a term that describes the spatial problem-solving process that a person uses to reach a destination. A mental “map” is formed of the overall setting and the desired destination. This map is based on information obtained from “orientation cues” that are available from the setting’s environment. These cues include not only *signage*, but also the overall spatial forms, structures, sounds, surface textures, colours, illumination levels, architectural features, etc. *Tactile* maps and/or recorded instructions can augment these orientation cues and enable people to find their way independently, even in complex settings. A well-designed setting can thus be spatially gratifying and simple enough for persons to “wayfind” if there are adequate, varied, and non-conflicting wayfinding cues available to the individual user.

Appropriate wayfinding ensures users can answer the following questions:

- Where am I?
- Which way am I facing?
- Is this the route to my destination?
- Is it easy for me to find my way back and to all main public facilities?

### DESIGN CONSIDERATIONS

Wayfinding shall:

- Assume all *building* or public open space users are first time visitors;
- Provide journey based information – Providing information at appropriate points in a journey that allow users to know where they are, where their destination is, what route they should take, how to recognize the destination and how to find their way back;
- Keep messages and strategies simple – Uncluttered, ground and floor surfaces free of confusing or apparent directional patterns, comprehensible to people with a broad range of abilities and language skills;
- One message at a time – Allow users to travel from one decision point to the next with a step by step approach to reach destination;
- Employ Universal Design Strategies – Consistency of message and terminology, Consistency in typography and colour, Consistency in placement of messages, Placement of signs is critical and takes into account age of reader, use of *assistive devices*;
- Provide Wayfinding Maps – You are here locations on each map, located at floor directories, *tactile* maps, simple and schematic (eg. Principal *entrance*, parking areas and pay books, information/reception desk(s), public zones and *common-use* destinations, exits, and kiosks or self-help areas);
- *Signage* zones – Placed consistently on each floor such as near public elevators and along public circulation routes, *clear floor space* minimum 1500 deep at *signage* and maps placed outside of the main *path of travel*;

## Exhibit A

- Information content – Will be organized in a logical order, use plain language and identify information such as *accessible services/facilities* on the premises, as well as other content appropriate to the *building* use and major occupancy;
- *Signage* locations shall indicate the *accessible route* from vehicular and pedestrian entry to the *site* to the parking and main *entrance*, *accessible site facilities*, passenger loading zones, directional *signage* to vertical circulation *elements*, information desk and washrooms;
- Elevator lobbies with floor directories, map of floor, directional *signage* to common destinations; Coordinate *signage* requirements with security needs;
- Acoustics – Sound transmission/reflection characteristics of finish materials shall aurally differentiate major and secondary *paths of travel*;
- Landmarks – Shall create an identity at specific decision making locations that helps to differentiate them from all other locations on the *site*; Shall be memorable visible and/or audible and/or scented; Include appropriate auditory cues along circulation routes and at destination points serve as useful wayfinding clues, especially for persons who rely upon hearing to orient themselves;
- *Tactile direction indicators* (or Guidance Tactile Warning Surface Indicators)– Shall be provided in large open floor areas, such as *building* entry lobbies, shopping malls or transportation terminals, to facilitate wayfinding by indicating the primary paths of travel. The TDIs shall lead from the *entrance* points to major destinations, such as an information or registration desk and elevator;
- Clearly defined boundaries – High colour and tonal contrast in materials in flooring shall enhance defining such as the junction between walls and floors, doorway recesses and corridor intersections;
- Visual characterizations – Regions or departments shall use some form of different visual characterization to define each as distinct from other areas;
- *Handrails* – Provide along major corridors, all stairs and *ramps* to serve as a visual and *tactile* way finding guides as well as to help maintain balance, and prevent falls. Braille in-sets may be provided on the surface of *handrails* where they end at landings or open spaces that identify the users locations;
- Lighting – Provided to delineate the pedestrian route, as well as to emphasize *building* features, such as *entrances*, stairs, *ramps*, or *signage*; and
- Google indoor maps can be investigated and implemented for select public *facilities*.

## APPENDIX C - COLOUR/BRIGHTNESS CONTRAST

**Note:** The following is an excerpt from “Clearing Our Path: Universal design recommendations for people with loss” by the CNIB.

The role of colour and brightness contrast is integral to how people negotiate and understand the built environment.

**Colour contrast** is the degree of difference between one colour and another on the colour wheel: the more visually different the colours, the greater the contrast.

**Brightness contrast** (also known as luminance contrast) is the difference in brightness between one object or surface and another: the greater the difference in brightness levels, the greater the contrast.

A person with excellent vision could enter a well-designed and logically organized building with good signage, little or no glare and minimum shadowing and still experience a sense of disorientation if there's little contrast in the colour or brightness of their surroundings. These problems increase significantly for a person with vision loss.

In the built environment, colour and brightness contrast can be used effectively for many purposes. It can be used to identify a door opening, to draw attention to signage and to define a path of travel. It can also be used for orientation. For example, a building designer may opt to use different colours for different sections or floors in a building. However, consistency and simplicity are also important. Providing colour and brightness contrast at every turn or change in architectural detail can be confusing.

To benefit someone with vision loss, all parts of a built environment must be considered when it comes to colour and brightness contrast. For example, a light-coloured door against a light-coloured wall would be easier to identify if the door frame and door were a dark colour, such as brown. A sign is much easier to locate when its colour and brightness contrast to the surrounding wall surface.

Wherever possible, the colour and brightness contrast of key elements (i.e. wall and floor) in the built environment should be at least 70 per cent.

Use a light meter to measure the colour and brightness contrast of surfaces. Hold the light meter 200 – 250 mm above the brighter surface (B1) to measure its light reflectance value (LRV). Then do the same with the darker surface (B2). Plug your measures into this formula:

**Colour/brightness contrast =  $(B1 - B2) \times 100 / B1$**

Manufacturers often provide LRVs on paint chips and other material samples. LRV calculators can also be found online.

Follow these guidelines to produce colour and brightness contrast for exterior spaces, interior spaces and signs:

- Use noticeably different colours side by side to distinguish different key building elements. Some good combinations are:

- Black/white
- Yellow/black
- Chocolate brown/white
- Dark blue/white
- Dark red/white
- Dark purple/white
- Dark green/white
- Orange/black
- Avoid these colour combinations, which have poor contrast:
  - Yellow/grey
  - Yellow/white
  - Black/violet
  - Red/black
  - Grey/white
  - Light blue/white
- Avoid these colour combinations, which have poor contrast and are particularly difficult for people with colour blindness:
  - Red/green
  - Blue/green
- White lettering on a dark background is easier to read for people with vision loss than dark letters on a white background.
- Keep colour schemes simple to avoid confusion in your design. Too many colours and busy patterns create confusion.
- Be consistent in the use of colours to convey specific information. For example, use one colour for all entrances to women's washrooms in a building and a *contrasting* colour for all entrances to men's washrooms.
- When it's impossible to adjust the colour or contrast of an item, consider other options. For example, when the colours in a corporate logo can't be changed and the logo includes colours with poor contrast, place a *contrasting* border around logo signage.



# Appendix D: FADS Checklist

|  |  |                      |
|--|--|----------------------|
| <b>APPENDIX D: FADS CHECKLIST</b>  |  | <b>Project Name:</b> |
| <b>Project Number:</b>   | <b>Project Type:</b>   |                      |
| <b>Project Phase:</b>  | <input type="checkbox"/> New Construction<br><input type="checkbox"/> Renovation/Alteration<br><input type="checkbox"/> Exterior Only<br><input type="checkbox"/> Other (Please Specify) |                      |
| <input type="checkbox"/> Preliminary (Concept Design)<br><input type="checkbox"/> Design Development<br><input type="checkbox"/> Other   |  |                      |
| <p>The City of Kingston’s Facility Accessibility Design Standards (FADS) is a mandatory design aid, applicable to the design and construction of new facilities, as well as the retrofit, alternation or addition to existing facilities owned, leased or operated by the City of Kingston for municipal purposes. This design checklist has been developed to assist staff, designers and contracted consultants with the application of FADS to ensure that each element has been applied to each project, and to document elements of a project that may be technically infeasible to implement.</p> <p>In a retrofit situation where a design element has little likelihood of being accomplished due to structural conditions or other physical or site constraints prohibit modification, the TECHNICAL INFEASIBILITY JUSTIFICATION FORM shall be completed by the designer and acknowledged by the City of Kingston’s staff member responsible for the project.</p> <p>Where an equivalent means of facilitation is being proposed to achieve the intent of part of the FADS, an EQUIVALENT FACILITATION PROPOSAL FORM shall be completed by the designer and acknowledged by the City of Kingston’s staff member responsible for the project.</p> <p>This checklist is a reference tool only and must be used in conjunction with the FADS document. The consultant or City staff shall complete this checklist during the design phase of each project.</p> |  |                      |

| <b>Site Design</b> |                                 |                   |    |                 |
|--------------------|---------------------------------|-------------------|----|-----------------|
| FADS               | Element/System                  | Compliance Status |    |                 |
|                    |                                 | Yes               | No | Comments or N/A |
| 4.1.2              | Ground and Floor Surfaces       |                   |    |                 |
| 4.1.3              | Protruding/Overhead Objects     |                   |    |                 |
| 4.1.4              | Accessible Routes               |                   |    |                 |
| 4.1.5              | Entrances                       |                   |    |                 |
| 4.1.9              | Ramps                           |                   |    |                 |
| 4.1.10             | Curb Ramps                      |                   |    |                 |
| 4.1.11             | Stairs                          |                   |    |                 |
| 4.3.12             | Parking                         |                   |    |                 |
| 4.3.13             | Passenger Loading Zones         |                   |    |                 |
| 4.3.14             | Landscaping                     |                   |    |                 |
| 4.3.15             | Benches                         |                   |    |                 |
| 4.3.16             | Picnic Tables                   |                   |    |                 |
| 4.3.17             | Street Furniture                |                   |    |                 |
| 4.4.3              | Vending & ticketing machines    |                   |    |                 |
| 4.4.7              | Signage                         |                   |    |                 |
| 4.4.8              | Detectable Warning Surfaces     |                   |    |                 |
| 4.4.13             | Lighting                        |                   |    |                 |
| 4.4.14             | Materials and Finishes          |                   |    |                 |
| 4.4.15             | Texture and Colour              |                   |    |                 |
| 4.5.2              | Outdoor Recreational Facilities |                   |    |                 |
| 4.5.3              | Swimming Pools                  |                   |    |                 |
| 4.5.10             | Transportation Facilities       |                   |    |                 |

| <b>Building Design</b> |  |                   |    |                 |
|------------------------|--|-------------------|----|-----------------|
| FADS                   | Element/System                         | Compliance Status |    |                 |
|                        |  | Yes               | No | Comments or N/A |
| <b>4.1.1</b>           | <b>Space and Reach</b>                 |                   |    |                 |
| 4.1.2                  | Ground and Floor Surfaces              |                   |    |                 |
| 4.1.3                  | Protruding/Overhead Objects            |                   |    |                 |
| 4.1.4                  | Accessible routes, paths and corridors |                   |    |                 |
| 4.1.5                  | Entrances                              |                   |    |                 |
| 4.1.6                  | Doors                                  |                   |    |                 |
| 4.1.7                  | Gates, Turnstiles                      |                   |    |                 |
| 4.1.8                  | Windows                                |                   |    |                 |
| 4.1.9                  | Ramps                                  |                   |    |                 |
| 4.1.11                 | Stairs                                 |                   |    |                 |
| 4.1.12                 | Handrails                              |                   |    |                 |
| 4.1.13                 | Escalators                             |                   |    |                 |
| 4.1.14                 | Elevators                              |                   |    |                 |
| 4.1.15                 | Platform Lifts                         |                   |    |                 |
| 4.2.1                  | Toilet Facilities                      |                   |    |                 |
| 4.2.2                  | Toilet Stalls                          |                   |    |                 |
| 4.2.3                  | Toilets                                |                   |    |                 |
| 4.2.4                  | Lavatories                             |                   |    |                 |
| 4.2.5                  | Urinals                                |                   |    |                 |
| 4.2.6                  | Washroom Accessories                   |                   |    |                 |
| 4.2.7                  | Individual Washrooms                   |                   |    |                 |
| 4.2.8                  | Bathtubs                               |                   |    |                 |

| <b>Building Design</b> |   |                   |    |                 |
|------------------------|---|-------------------|----|-----------------|
| FADS                   | Element/System                              | Compliance Status |    |                 |
|                        |   | Yes               | No | Comments or N/A |
| 4.2.9                  | Shower Stalls                               |                   |    |                 |
| 4.2.10                 | Grab Bars                                   |                   |    |                 |
| 4.3.1                  | Drinking fountains                          |                   |    |                 |
| 4.3.2                  | Viewing Positions                           |                   |    |                 |
| 4.3.3                  | Elevated Platforms                          |                   |    |                 |
| 4.3.4                  | Dressing Rooms                              |                   |    |                 |
| 4.3.5                  | Offices, Work areas                         |                   |    |                 |
| 4.3.6                  | Waiting and Queuing areas                   |                   |    |                 |
| 4.3.7                  | Tables, counters and work surfaces          |                   |    |                 |
| 4.3.8                  | Information, reception and service counters |                   |    |                 |
| 4.3.9                  | Storage, shelving and display units         |                   |    |                 |
| 4.3.10                 | Lockers and baggage storage                 |                   |    |                 |
| 4.3.11                 | Balconies, porches, terraces and patios     |                   |    |                 |
| 4.3.18                 | Kitchens and Kitchenettes                   |                   |    |                 |
| 4.4.1                  | Emergency Exits, Fire evacuation            |                   |    |                 |
| 4.4.3                  | Vending and ticketing machines              |                   |    |                 |
| 4.4.2                  | Controls, operating mechanisms              |                   |    |                 |
| 4.4.4                  | Visual alarms                               |                   |    |                 |
| 4.4.5                  | Public telephones                           |                   |    |                 |

| <b>Building Design</b> |  |                   |    |                 |
|------------------------|--|-------------------|----|-----------------|
| FADS                   | Element/System                                       | Compliance Status |    |                 |
|                        |  | Yes               | No | Comments or N/A |
| 4.4.6                  | Assistive Listening systems                          |                   |    |                 |
| 4.4.7                  | Signage  |                   |    |                 |
| 4.4.8                  | Detectable warning surfaces                          |                   |    |                 |
| 4.4.9                  | Public Address systems                               |                   |    |                 |
| 4.4.10                 | Information systems                                  |                   |    |                 |
| 4.4.11                 | Card access, safety and security systems             |                   |    |                 |
| 4.4.12                 | Glare and light sources                              |                   |    |                 |
| 4.4.13                 | Lighting   |                   |    |                 |
| 4.4.14                 | Materials and finishes                               |                   |    |                 |
| 4.4.15                 | Texture and colour                                   |                   |    |                 |
| 4.4.16                 | Acoustics  |                   |    |                 |
| 4.5.1                  | Arenas, halls and other Indoor Recreation Facilities |                   |    |                 |
| 4.5.3                  | Swimming Pools                                       |                   |    |                 |
| 4.5.4                  | Cafeterias   |                   |    |                 |
| 4.5.5                  | Churches, chapels and other places of worship        |                   |    |                 |
| 4.5.6                  | Libraries  |                   |    |                 |
| 4.5.7                  | Business, mercantile and civic                       |                   |    |                 |
| 4.5.8                  | Police stations                                      |                   |    |                 |
| 4.5.9                  | Municipal courts                                     |                   |    |                 |
| 4.5.10                 | Transportation Facilities                            |                   |    |                 |
| 4.5.11                 | Fire Halls   |                   |    |                 |

| <b><u>Building Design</u></b> |                        |                   |    |                 |
|-------------------------------|------------------------|-------------------|----|-----------------|
| FADS                          | Element/System         | Compliance Status |    |                 |
|                               |                        | Yes               | No | Comments or N/A |
| 4.5.12                        | Airport                |                   |    |                 |
| 4.5.13                        | Residential facilities |                   |    |                 |

**Applicant:**

I have utilized this Checklist as a design aid in conjunction with the FADS document throughout the design phase of this project, and confirm FADS compliance throughout the project Scope of Work design documents.

Project Designer: \_\_\_\_\_

Company: \_\_\_\_\_

Date: \_\_\_\_\_

**Acknowledgement:**

**City of Kingston staff responsible for the project:** \_\_\_\_\_

# Appendix E: Technical Infeasibility Justification Form

|  |  |
|--|--|
| <b>Project Name:</b>   |  |
| <b>Project Number:</b>   | <b>Project Type:</b>   |
| <b>Project Phase:</b>  | <input type="checkbox"/> New Construction<br><input type="checkbox"/> Renovation/Alteration<br><input type="checkbox"/> Exterior Only<br><input type="checkbox"/> Other (Please Specify) |
| <input type="checkbox"/> Preliminary (Concept Plan)<br><input type="checkbox"/> Design Development<br><input type="checkbox"/> Other (Please Specify)  |  |
| Technical infeasibility means, with respect to an alteration of a building or a facility, that it has little likelihood of being accomplished due to structural conditions or other physical or site constraints |  |

1. City of Kingston FADS Requirement (Please provide Section/Item No.)

\_\_\_\_\_

2. Please describe the intent of the accessibility requirement

\_\_\_\_\_  
 \_\_\_\_\_

3. Please describe why achieving the accessibility requirement is technically infeasible.

\_\_\_\_\_  
 \_\_\_\_\_

4. Is alternate design from FADS being proposed? (If so, please complete the Alternate Design from FADS Proposal Form. If not, please explain why not.)

\_\_\_\_\_  
 \_\_\_\_\_

Please use additional sheets as necessary

**Applicant:**

Project Designer: \_\_\_\_\_

Company: \_\_\_\_\_

Date: \_\_\_\_\_

**Acknowledgement:**

City of Kingston staff responsible for the project: \_\_\_\_\_

# Appendix F: Equivalent Facilitation Proposal Form

|   |  |
|---|--|
| <b>Project Name:</b>  |  |
| <b>Project Number:</b>  | <b>Project Type:</b>   |
| <b>Project Phase:</b>   | <input type="checkbox"/> New Construction<br><input type="checkbox"/> Renovation/Alteration<br><input type="checkbox"/> Exterior Only<br><input type="checkbox"/> Other (Please Specify) |
| <input type="checkbox"/> Preliminary (Concept Plan)<br><input type="checkbox"/> Design Development<br><input type="checkbox"/> Other (Please Specify) |  |

1. City of Kingston FADS Requirement (Please provide Section/Item No.)

---

2. Please describe the intent of the accessibility requirement

---



---

3. Please describe your reasons for proposing an alternate design.

---



---

4. Please describe how your proposed alternate design meets the intent of the accessibility requirement of the City of Kingston's FADS

---



---

Please use additional sheets as necessary

**Applicant:**

Project Designer: \_\_\_\_\_

Company: \_\_\_\_\_

Date: \_\_\_\_\_

**Acknowledgement:**

City of Kingston staff responsible for the project: \_\_\_\_\_